

Installation Manual

GPS PLOTTER/SOUNDER GP-1670F

GP-1870F

SAFETY INSTRUCTIONS	i
1. MOUNTING	1-1
1.1 Mounting of Display Unit	1-1
1.2 Replacement Kit (option)	1-2
2. INSTALLATION OF TRANSDUCERS	2-1
2.1 How to Mount a Transducer through the Unit	2-1
2.2 Transom Mount Transducer	2-3
2.3 How to Mount a Transducer inside the Hull	2-4
3. WIRING	3-1
3.1 Display Unit	3-1
3.2 Transducer	3-2
3.3 External Equipment.....	3-2
PACKING LIST	A-1
OUTLINE DRAWINGS	D-1
INTERCONNECTION DIAGRAMS	S-1



FURUNO ELECTRIC CO., LTD.

www.furuno.com



All brand and product names are trademarks, registered trademarks or service marks of their respective holders.







SAFETY INSTRUCTIONS







The user and installer must read the appropriate safety instructions before attempting to install or operate the equipment.

The operator must read the safety instructions before attempting to operate the equipment.

 WARNING	Indicates a potentially hazardous situation which, if not avoided, could result in death or serious injury.
 CAUTION	Indicates a potentially hazardous situation which, if not avoided, could result in minor or moderate injury.

 Warning, Caution	 Prohibitive Action	 Mandatory Action
--	--	--

 WARNING	
 Do not open the equipment.	The equipment uses high voltage that can cause electrical shock. Refer any repair work to a qualified technician.
 If water leaks into the equipment or something is dropped into the equipment, immediately turn off the power at the switchboard.	Fire or electrical shock can result.
 If the equipment is giving off smoke or fire, immediately turn off the power at the switchboard.	Fire or electrical shock can result.
 If you feel the equipment is acting abnormally or giving off strange noises, immediately turn off the power at the switchboard and contact a FURUNO service technician.	

 WARNING	
 Do not disassemble or modify the equipment.	Fire, electrical shock or serious injury can result.
 Make sure no rain or water splash leaks into the equipment.	Fire or electrical shock can result if water leaks into the equipment.
 Do not place liquid-filled containers on or near the equipment.	Fire or electrical shock can result if a liquid spills into the equipment.
 Do not operate the equipment with wet hands.	Electrical shock can result.
 Use the proper fuse.	Use of the wrong fuse can cause fire or electrical shock.

1. MOUNTING

1.1 Mounting of Display Unit

Mounting considerations

The display unit can be installed on a tabletop or flush mounted in a console.

Select a suitable mounting location considering the following:

- Keep the display unit out of direct sunlight.
- The temperature and humidity should be moderate and stable.
- Locate the unit away from exhaust pipes and vents.
- The mounting location should be well ventilated.
- Mount the unit where shock and vibration are minimal.
- Keep the unit away electromagnetic field generating equipment such as motor, generator.
- For maintenance and checking purposes, leave sufficient space at the sides and rear of the unit and leave slack in cables.
- A magnetic compass will be affected if placed too close to the display unit. Observe the compass safe distances shown in the Safety Instructions to prevent disturbance to the magnetic compass:

Mounting procedure

Follow the procedure below to mount the display unit on a tabletop or in a console. Refer to the outline drawing at the back of this manual.

• Tabletop, mounting

1. Fix the hanger by four tapping screws $\phi 4.8 \times 22$.
2. Screw knob bolts in display unit, set it to hanger, and tighten knob bolts.
3. Attach hard cover to protect LCD.

• Flush mounting

Follow the procedure below to mount the display unit in a console. Refer to the outline drawing at the back of this manual.

1. The thickness of the cutout should be 5 to 20 mm.
2. Prepare a cutout in the mounting location whose dimensions are shown in the outline drawing at the back of this manual.
3. Screw in four threaded rods into the display unit.
4. Peel the paper from flush mount gasket and set the gasket to the display unit.
5. Set the display unit to the cutout and fasten it with the washers and nuts.

1.2 Replacement Kit (option)

For replace from the flush mounted former type display unit (GP-1650 ser.) to GP-1670F/1870F, the replacement kit (option) is available. Follow the procedure below to replace a display unit.

1. Remove the former display unit from panel.
2. Fix the display unit GP-1670F/1870F onto the replacement kit by four lods, washer and nuts.
3. Set the display unit to the cutout and fasten it with four tapping screws $\phi 5 \times 20$.

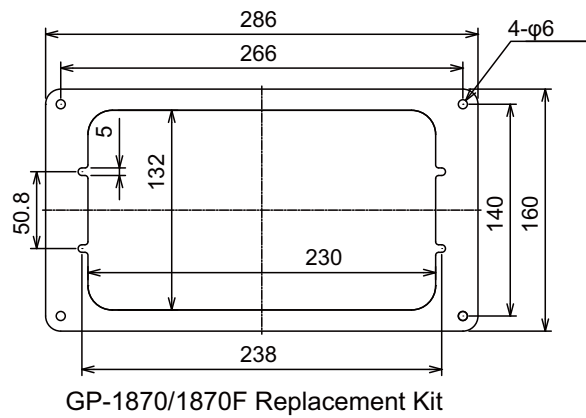
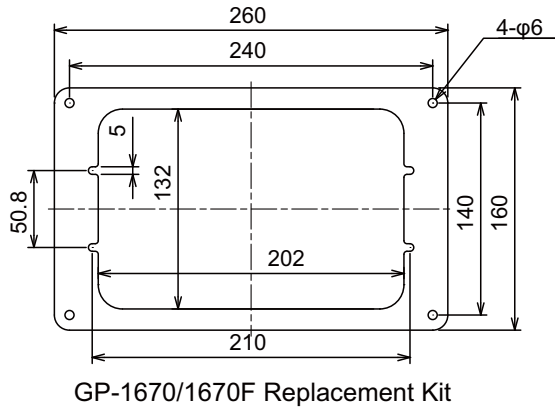

2. INSTALLATION OF TRANSDUCERS

2.1 How to Mount a Transducer through the Unit

Transducer mounting location

The thru-hull mount transducer provides the best performance of all, since the transducer protrudes from the hull and the effect of air bubbles and turbulence near the hull skin is reduced. When the boat has a keel, the transducer should be at least 30 cm away from it.

The performance of this fish finder is directly related to the mounting location of the transducer, especially for high-speed cruising. The installation should be planned in advance, keeping the length of the transducer cable and the following factors in mind:

- Air bubbles and turbulence caused by movement of the boat seriously degrade the sounding capability of the transducer. The transducer should, therefore, be located in a position where water flow is the smoothest. Noise from the propellers also adversely affects performance and the transducer should not be mounted nearby. The lifting strakes are notorious for creating acoustic noise, and these must be avoided by keeping the transducer inboard of them.
- The transducer must always remain submerged, even when the boat is rolling, pitching or up on a plane at high speed.
- A practical choice would be somewhere between 1/3 and 1/2 of the boat's length from the stern. For planing hulls, a practical location is generally rather far astern, so that the transducer is always in water regardless of the planing attitude.

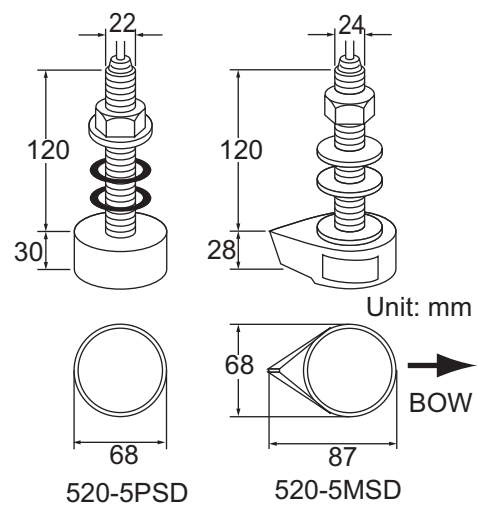

2. INSTALLATION OF TRANSDUCERS

Transducer mounting locations

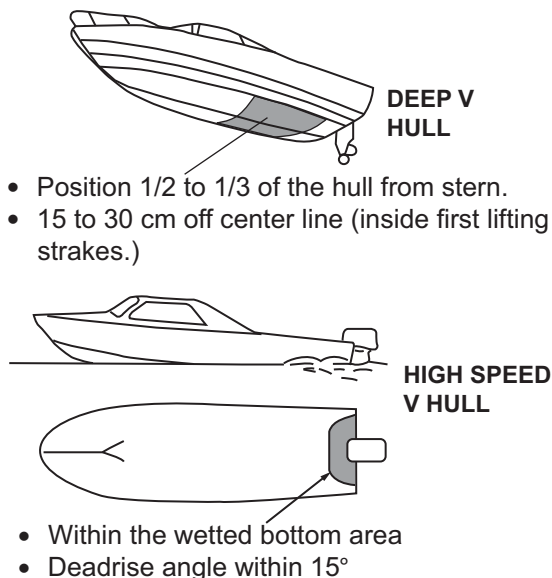

Installation procedure

1. With the boat hauled out of the water, mark the location chosen for mounting the transducer on the bottom of the hull.
2. If the hull is not level within 15° in any direction, fairing blocks made out of teak should be used between the transducer and hull, both inside and outside, to keep the transducer face parallel with the water line. Fabricate the fairing block as shown below and make the entire surface as smooth as possible to provide an undisturbed flow of water around the transducer. The fairing block should be smaller than the transducer itself to provide a channel to divert turbulent water around the sides of the transducer rather than over its face.

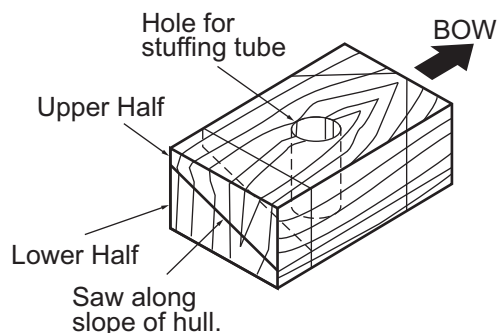

3. Drill a hole just large enough to pass the threaded stuffing tube of the transducer through the hull, making sure it is drilled vertically.
4. Apply a sufficient amount of high quality caulking compound to the top surface of the transducer, around the threads of the stuffing tube and inside the mounting hole (and fairing blocks if used) to ensure watertight mounting.

- Mount the transducer and fairing blocks and tighten the locknut. Be sure that the transducer is properly oriented and its working face is parallel to the waterline.

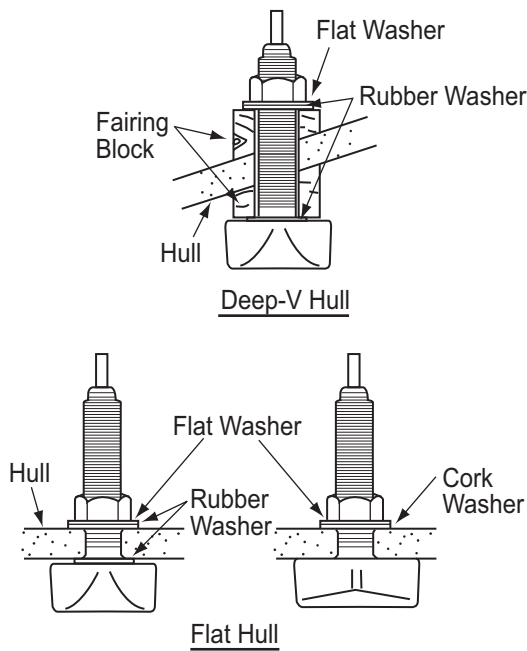

Note: Do not over-stress the stuffing tube and locknut through excessive tightening, since the wood block will swell when the boat is placed in the water. It is suggested that the nut be tightened lightly at installation and retightened several days after the boat has been launched.

Transducer preparation

Before putting the boat in water, wipe the face of the transducer thoroughly with a detergent liquid soap. This will lessen the time necessary for the transducer to have good contact with the water. Otherwise the time required for complete "saturation" will be lengthened and performance will be reduced.

DO NOT paint the transducer. Performance will be affected.

2.2 Transom Mount Transducer

The optional transom mount transducer is very commonly employed, usually on relatively small I/O or outboard boats. Do not use this method on an inboard motor boat because turbulence is created by the propeller ahead of the transducer.

DO NOT overtighten screws; they may be damaged.

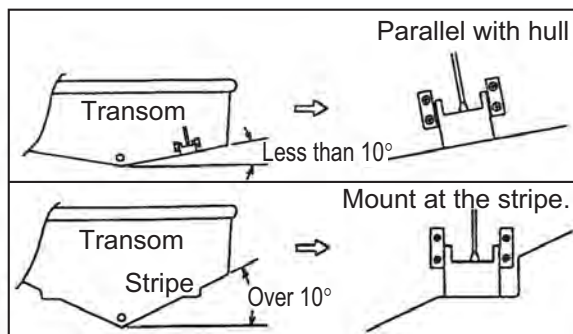

2. INSTALLATION OF TRANSDUCERS

Installation procedure

A suitable mounting location is at least 50 cm away from the engine and where the water flow is smooth.

1. Drill four pilot holes for self-tapping screw (5x20) in the mounting location.
2. Coat the threads of the self-tapping screws (5x14) for the transducer with silicone sealant for waterproofing. Attach the transducer to the mounting location with the self-tapping screws.
3. Adjust the transducer position so the transducer faces right to the bottom. If necessary, to improve water flow and minimize air bubbles staying on the transducer face, incline the transducer about 5° at the rear. This may require a certain amount of experimentation for fine tuning at high cruising speeds.
4. Tape the location shown in the figure below.

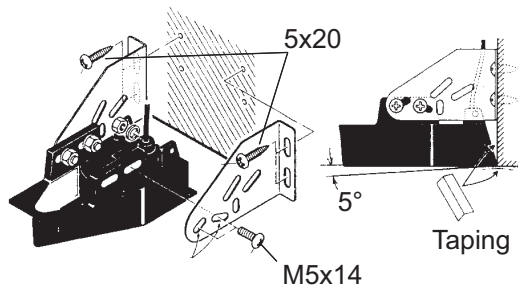

5. Fill the gap between the wedge front of the transducer and transom with epoxy material to eliminate any air spaces.
6. After the epoxy hardens, remove the tape.

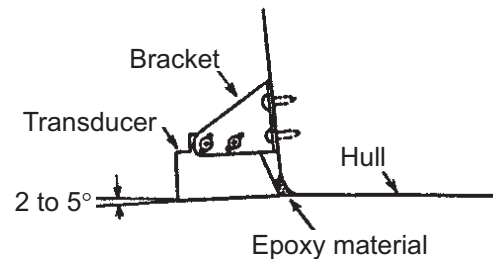

2.3 How to Mount a Transducer inside the Hull

The transducer may also be installed inside the hull on FRP boats. However, this installation method affects the ability to detect the bottom, fish and other objects because the ultrasound pulse is weakened when it passes through the hull.

Note: This mounting method should not be used to mount the transducer that supports the ACCU-FISH™ and/or bottom discrimination display feature, since performance is greatly degraded.

Necessary tools

You will need the following tools:

- Sandpaper (#100)
- Silicone sealant
- Silicone grease

Remarks on installation

- Do the installation with the ship moored at a dock, etc. The water depth should be 6.5-32 feet (2-10 meters).
- Turn off the engine.
- Install the transducer with the engine room.
- Do not power the unit with the transducer in the air, to prevent damage to the transducer.
- Do not use this method on a double layer hull.
- Before attaching the transducer to the hull, check that the site is suitable. Put the transducer in a water-filled plastic bag. Connect the transducer to the display unit and put the transducer on the installation site. Turn on the display unit and check that the depth indication appears.

Installation procedure

If the thickness of the hull varies, then the attenuation of the ultrasound pulse. Select a location where attenuation is the lowest.

1. Select 2-3 locations considering the four points mentioned below. (You will finalize the mounting location through some trial and error later.)
 - Mount the transducer at a location $1/2$ to $1/3$ of the length of the boat from the stern.
 - The mounting location is between 15 to 50 cm from the centerline of the hull.
 - Do not place the transducer over hull struts or ribs which run under the hull.
 - Avoid a location where the rising angle of the hull exceeds 15° , to minimize the effect of the boat's rolling.

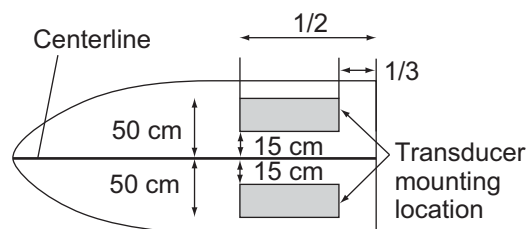

2. Clean the face of the transducer to remove any foreign material. Lightly roughen the face with #100 sandpaper. Also, use the sandpaper to roughen the inside of the hull where the transducer is to be mounted.
3. Wipe off any sandpaper dust from the face of the transducer.
4. Dry the face of the transducer and the hull. Coat the transducer face and mounting location with silicone sealant. Hardening begins in approx. 15-20 minutes so do this step without delay.

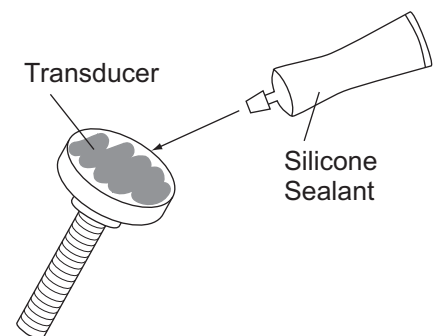

2. INSTALLATION OF TRANSDUCERS

5. Attach the transducer to the hull.
Press the transducer firmly down on the hull and gently twist it back and forth to remove any air which may be trapped in the silicone sealant.
6. Support the transducer with a piece of wood to keep it in place while the sealant is drying. It takes 24-72 hours to harden completely.

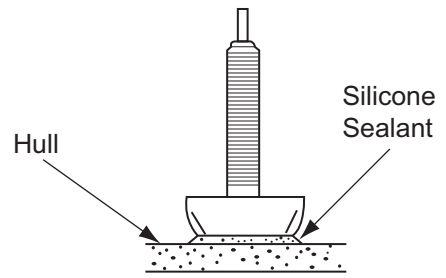

3. WIRING

3.1 Display Unit

All wiring are terminated at the rear of the display unit. Refer to the interconnection diagram on page S-1.

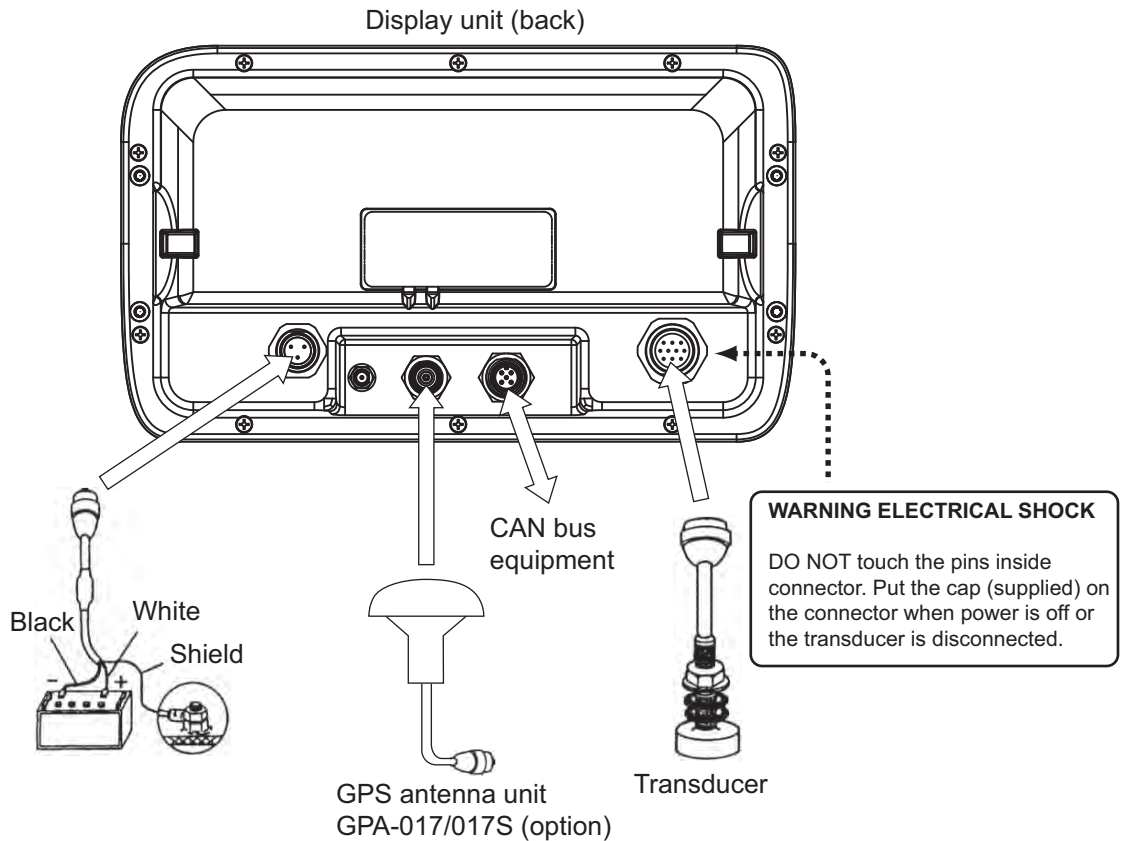

Power cable

Connect the power cable to the power connector. Connect the leads to the battery (12 or 24 VDC); white to plus(+) terminal and black to minus(-) terminal. Ground the shield to ship's ground.

Note: The fuse is not waterproof. Wrap the fuse holder with vinyl tape to keep water out of the fuse holder.

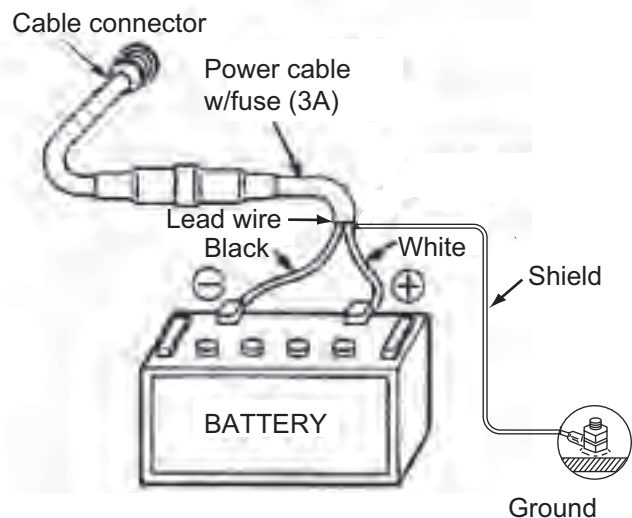

3.2 Transducer

Connect the transducer cable to the XDR port.

Transducer and sensor

Use the optional conversion cable (02S4147) to connect the optional speed/temperature sensor and the transducer to the XDR port. Refer to Operator's Manual in detail.

Matching box (option, required for 1 kW transducer)

The optional matching box (Type: MB-1100, Code No.: 000-041-353) is required to connect the optional transducers 50B-6, 50B-6B, 200B-5S, 50/200-1T and 50/200-12M.

Part	Type	Code no.	Qty
Matching Box*	MB-1100	000-041-000	1
Crimp-on Lug	FV1.25-3 (LF)	000-116-756-10	6
Cord Lock**	NC-1	000-168-230-10	1

*: With 10P connector cable

** : For connecting two transducers

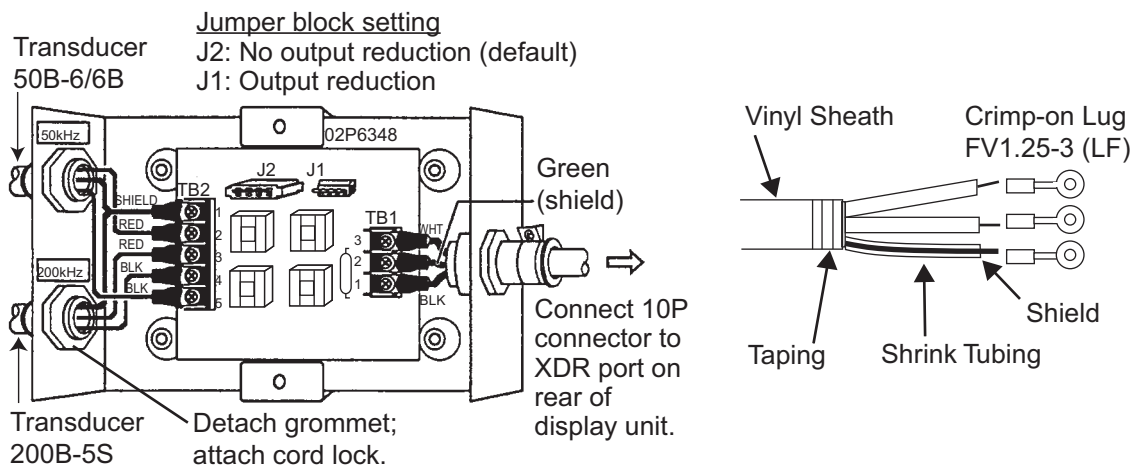

3.3 External Equipment

About CAN bus connections

CAN bus is a communication protocol that shares multiple data and signals through a single backbone cable. You can simply connect any CAN bus devices onto the backbone cable to expand your network onboard. With CAN bus, IDs are assigned to all the devices in the network, and the status of each sensor in the network can be detected. All the CAN bus devices can be incorporated into the NMEA2000 network. For detailed information about CAN bus wiring, see "Furuno CAN bus Network Design Guide" (Type: TIE-00170) on Tech-Net, or contact your dealer.

PACKING LIST GP-1670F-E

14CWF-X-9852-1

1/1

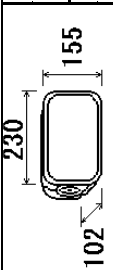
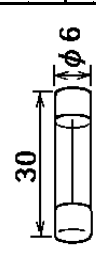
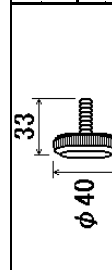
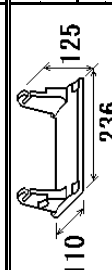
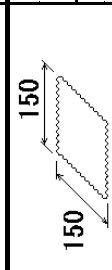
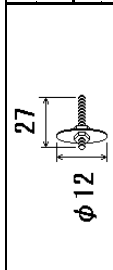
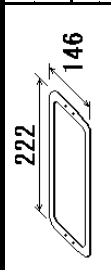
NAME	OUTLINE	DESCRIPTION/CODE No.	Q'TY
ユニット			
GPS7 ロック/魚探		GP-1670F	1
GPS PLOTTER/SOUNDER		999-999-194-00	(*)
予備品			
SPARE PARTS			
ヒューズ		0312 003. MXP	1
GLASS TUBE FUSE		999-999-186-00	(*)
付属品			
ACCESSORIES			
ノブ		VTSPKNOB-M6 FRN	2
KNOB		999-999-197-00	(*)
ハンガ-		HBS47A	1
EXTERNAL BRACKET		999-999-184-00	(*)
フィルタークリーナー		MINU CLOTH FRN	1
CLEANING CLOTH		999-999-183-00	(*)
工事材料			
INSTALLATION MATERIALS			
Fマウントネジ キット		K10LC3005A	4
FLUSH MOUNT SCREWS KIT		999-999-180-00	(*)
Fマウントパッキン		HGB10AX	1
FLUSH MOUNT GASKET		999-999-181-00	(*)

(*)は、タミコードに付き、注文できません。

(*) THIS CODE CANNOT BE ORDERED.

(略図の寸法は、参考値です。DIMENSIONS IN DRAWING FOR REFERENCE ONLY.)

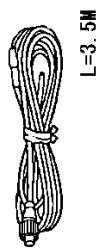
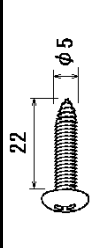
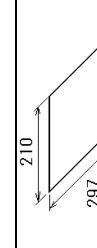
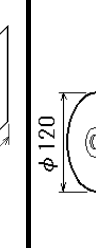
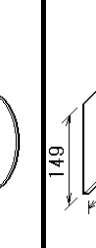
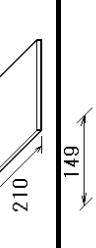
NAME	OUTLINE	DESCRIPTION/CODE No.	Q'TY
ケーブル(タミピン) MJ		MJ-A3SPF0013A-035C	1
CABLE ASSEMBLY		000-176-666-10	
タビピン		VTATM4. 8X22 TCC INX	4
EXTERNAL BRACKET FIXING SCREWS		999-999-179-00	(*)
図書			
DOCUMENT			
フラッシュマウント型紙		C42-01201-*	1
FLUSH MOUNTING TEMPLATE		999-999-187-00	(*)
取扱説明CD		GP-1X70 O/M *CD-ROM*	1
OPERATOR'S MANUAL CD		999-999-190-00	(*)
操作要領書(英/和)		OS*-44770-*	1
OPERATOR'S GUIDE (E/J)		999-999-189-00	(*)
装備要領書		IMC-44770-*	1
INSTALLATION MANUAL		999-999-192-00	(*)

型式/コード番号が2段の場合、下段より上段に代わる過渡期品であり、どちらかが入っています。なお、品質は変わりません。

TWO TYPES AND CODES MAY BE LISTED FOR AN ITEM. THE LOWER PRODUCT MAY BE SHIPPED IN PLACE OF THE UPPER PRODUCT. QUALITY IS THE SAME.

☆

A-1

C4477-Z01-B

PACKING LIST GP-1870F-E

14CX-X-9852-1

1/1

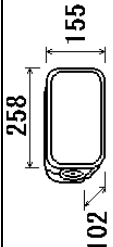
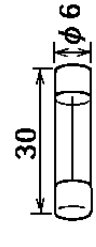
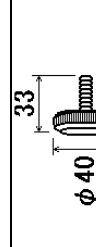
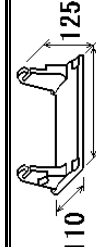
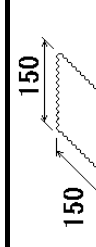
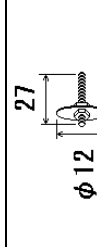
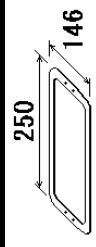
NAME	OUTLINE	DESCRIPTION/CODE No.	Q'TY
ユニット			
GPS7 ロック/魚探		GP-1870F	1
GPS PLOTTER/SOUNDER		999-999-196-00	(*)
予備品			
SPARE PARTS			
ヒューズ		0312 003. MXP	1
GLASS TUBE FUSE		999-999-186-00	(*)
付属品			
ACCESSORIES			
ノブ		VTSPKNOB-M6 FRN	2
KNOB		999-999-197-00	(*)
ハンガ-		HBS48AX	1
EXTERNAL BRACKET		999-999-185-00	(*)
フィルタークリーナー		MINU CLOTH FRN	1
CLEANING CLOTH		999-999-183-00	(*)
工事材料			
INSTALLATION MATERIALS			
Fマウントネジ キット		K10LC3005A	4
FLUSH MOUNT SCREWS KIT		999-999-180-00	(*)
Fマウントパッキン		HGB11AX	1
FLUSH MOUNT GASKET		999-999-182-00	(*)

(*)は、タミコードに付き、注文できません。

(*) THIS CODE CANNOT BE ORDERED.

(略図の寸法は、参考値です。DIMENSIONS IN DRAWING FOR REFERENCE ONLY.)

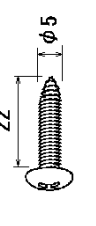
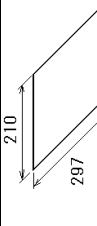
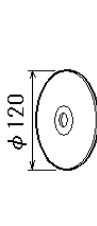
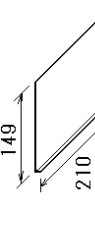
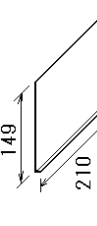
NAME	OUTLINE	DESCRIPTION/CODE No.	Q'TY
ケーブル(クミピン) MJ			
CABLE ASSEMBLY		MJ-A3SPF0013A-035C	1
		000-176-666-10	
クランプネジ			
EXTERNAL BRACKET FIXING SCREWS		VTATM4. 8X22 TCC INX	4
		999-999-179-00	(*)
図書			
DOCUMENT			
フラッシュマウント型紙		C42-01201-*	1
FLUSH MOUNTING TEMPLATE		999-999-187-00	(*)
取扱説明CD		GP-1X70 O/M *CD-ROM*	1
OPERATOR'S MANUAL CD		999-999-190-00	(*)
操作要領書(英/和)		OS*-44770-*	1
OPERATOR'S GUIDE (E/J)		999-999-189-00	(*)
装備要領書		IMC-44770-*	1
INSTALLATION MANUAL		999-999-192-00	(*)

型式/コード番号が2段の場合、下段より上段に代わる過渡期品であり、どちらかが入っています。なお、品質は変わりません。

TWO TYPES AND CODES MAY BE LISTED FOR AN ITEM. THE LOWER PRODUCT MAY BE SHIPPED IN PLACE OF THE UPPER PRODUCT. QUALITY IS THE SAME.

☆

A-2

C4479-Z01-B

PACKING LIST GP-1670F-J

14CW-X-9854-0

1/1

NAME	OUTLINE	DESCRIPTION/CODE No.	Q'TY
ユニット			
GPS7 ロッタ/魚探		GP-1670F	1
GPS PLOTTER/SOUNDER		999-999-194-00	(*)
予備品			
SPARE PARTS			
ヒューズ		0312 003.MXP	1
GLASS TUBE FUSE		999-999-186-00	(*)
付属品			
ACCESSORIES			
SDカード (NEWPEC)		NEWPEC AND9**.*	1
NEWPEC JAPAN JHA-NP SD CARD		999-999-198-00	(*)
ノブ		VTSPKNOB-IM6 FRN	2
KNOB		999-999-197-00	(*)
ハンガ-		HBS47A	1
EXTERNAL BRACKET		999-999-184-00	(*)
フィルター		MINU CLOTH FRN	1
CLEANING CLOTH		999-999-183-00	(*)
工事材料			
INSTALLATION MATERIALS			
F マウントネジ キット		K10LC3005A	4
FLUSH MOUNT SCREWS KIT		999-999-180-00	(*)

(*)は、タミコードに付き、注文できません。

(*) THIS CODE CANNOT BE ORDERED.

(略図の寸法は、参考値です。DIMENSIONS IN DRAWING FOR REFERENCE ONLY.)

NAME	OUTLINE	DESCRIPTION/CODE No.	Q'TY
Fマウントパッキン		HGB10AX	1
FLUSH MOUNT GASKET		999-999-181-00	(*)
ケーブル(ガミビ) MJ		MJ-A3SPF0013A-035C	1
CABLE ASSEMBLY		000-176-666-10	
タビネン		VTATM4.8X22 TCC INX	4
EXTERNAL BRACKET FIXING SCREWS		999-999-179-00	(*)
図書			
DOCUMENT			
フリップマウント型紙		C42-01201-*	1
FLUSH MOUNTING TEMPLATE		999-999-187-00	(*)
取扱説明CD		GP-1X70 O/M *CD-ROM*	1
OPERATOR'S MANUAL CD		999-999-190-00	(*)
操作要領書(英/和)		OS*-44770-*	1
OPERATOR'S GUIDE (E/J)		999-999-189-00	(*)
装備要領書		IMC-44770-*	1
INSTALLATION MANUAL		999-999-192-00	(*)

型式/コード番号が2段の場合、下段より上段に代わる過渡期品であり、どちらかが入っています。なお、品質は変わりません。

TWO TYPES AND CODES MAY BE LISTED FOR AN ITEM. THE LOWER PRODUCT MAY BE SHIPPED IN PLACE OF THE UPPER PRODUCT. QUALITY IS THE SAME.

☆



A-3

C4477-Z02-A

PACKING LIST GP-1870F-J

14CX-X-9854-0

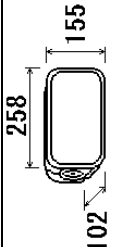
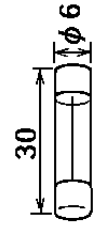
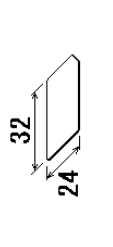
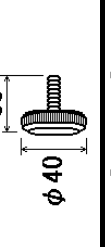
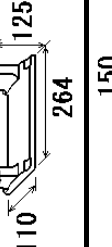
1/1

NAME	OUTLINE	DESCRIPTION/CODE No.	Q'TY
ユニット			
GPS7 ロック/魚探		GP-1870F	1
GPS PLOTTER/SOUNDER		999-999-196-00	(*)
予備品			
SPARE PARTS			
ヒューズ		0312 003.MXP	1
GLASS TUBE FUSE		999-999-186-00	(*)
付属品			
ACCESSORIES			
SDカード (NEWPEC)		NEWPEC AND9**.*	1
NEWPEC JAPAN JHA-NP SD CARD		999-999-198-00	(*)
ノブ		VTSPKNOB-IM6 FRN	2
KNOB		999-999-197-00	(*)
ハンガー		HBS48AX	1
EXTERNAL BRACKET		999-999-185-00	(*)
フィルター		MINU CLOTH FRN	1
CLEANING CLOTH		999-999-183-00	(*)
工事材料			
INSTALLATION MATERIALS			
F マウントネジ キット		K10LC3005A	4
FLUSH MOUNT SCREWS KIT		999-999-180-00	(*)

(*)は、タミコードに付き、注文できません。

(*) THIS CODE CANNOT BE ORDERED.

(略図の寸法は、参考値です。DIMENSIONS IN DRAWING FOR REFERENCE ONLY.)

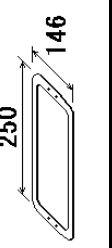
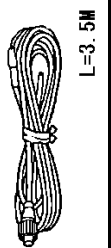
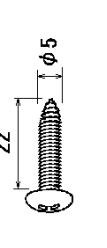
NAME	OUTLINE	DESCRIPTION/CODE No.	Q'TY
Fマウントパッキン		HGB11AX	1
FLUSH MOUNT GASKET		999-999-182-00	
ケーブル(ガミビ) MJ		MJ-A3SPF0013A-035C	1
CABLE ASSEMBLY		000-176-666-10	
タビネン		VTATM4.8X22 TCC INX	4
EXTERNAL BRACKET FIXING SCREWS		999-999-179-00	(*)

図書

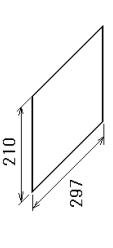
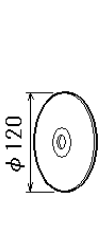
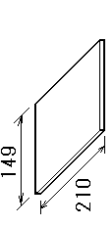
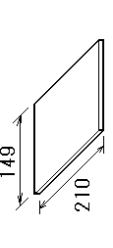
NAME	OUTLINE	DESCRIPTION/CODE No.	Q'TY
フリップマウント型紙		C42-01201-*	1
FLUSH MOUNTING TEMPLATE		999-999-187-00	(*)
取扱説明CD		GP-1X70 O/M *CD-ROM*	1
OPERATOR'S MANUAL CD		999-999-190-00	(*)
操作要領書(英/和)		OS*-44770-*	1
OPERATOR'S GUIDE (E/J)		999-999-189-00	(*)
装備要領書		IMC-44770-*	1
INSTALLATION MANUAL		999-999-192-00	(*)

型式/コード番号が2段の場合、下段より上段に代わる過渡期品であり、どちらかが入っています。なお、品質は変わりません。

TWO TYPES AND CODES MAY BE LISTED FOR AN ITEM. THE LOWER PRODUCT MAY BE SHIPPED IN PLACE OF THE UPPER PRODUCT. QUALITY IS THE SAME.

☆

A-4

C4479-Z02-A

表1 TABLE 1

寸法区分 (mm) DIMENSION	公差 (mm) TOLERANCE
L ≤ 50	±1.5
50 < L ≤ 100	±2.5
100 < L ≤ 500	±3

表2 TABLE 2

型式 MODEL	質量 MASS	質量公差 MASS TOL(%)
GP-1670	1.5	
GP-1670F	1.6	

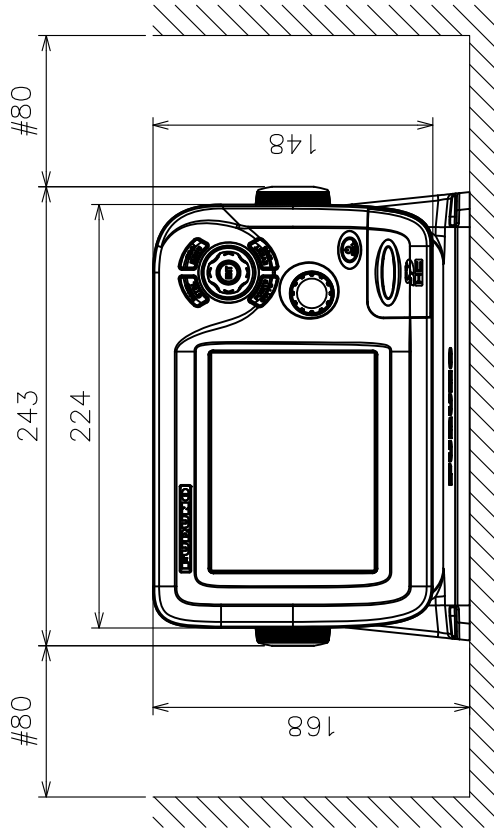
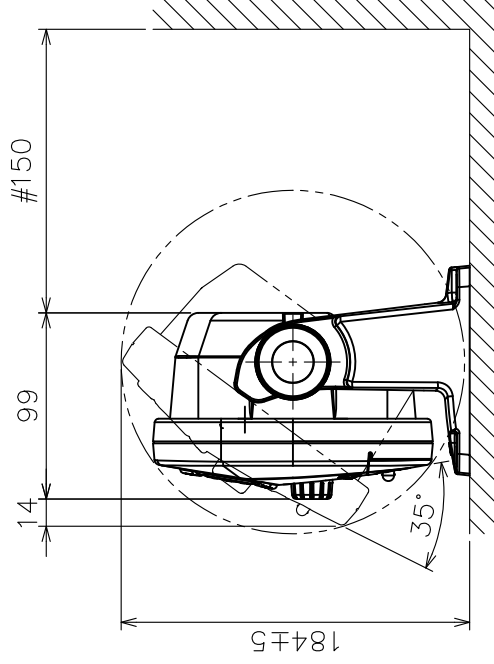
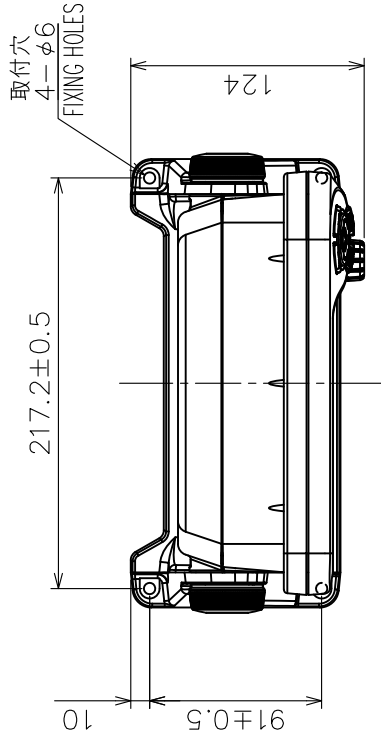
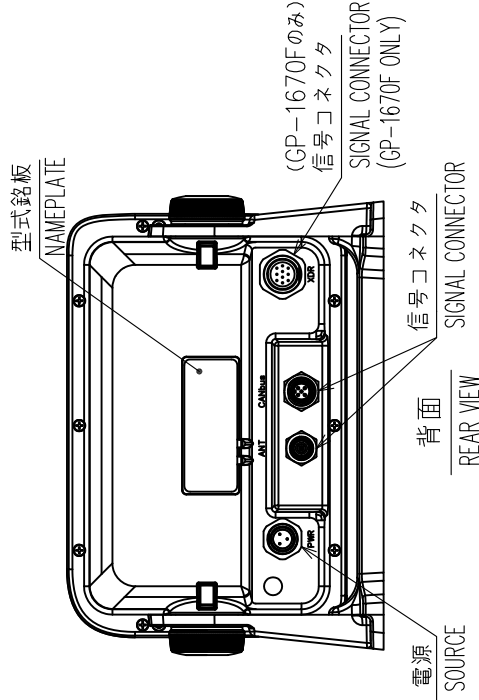

注 記

- 1) 指定外の寸法公差は表1による。
- 2) #印寸法は最小サービスクリアランスとする。
- 3) 取付用ネジはトラスターピッチネジ呼び径5を使用のこと。

NOTE

1. TABLE 1 INDICATES TOLERANCE OF DIMENSIONS WHICH IS NOT SPECIFIED.
2. #: MINIMUM SERVICE CLEARANCE.
3. USE TAPPING SCREWS φ4.8x22 FOR FIXING THE UNIT.

DRAWN 4/Apr/2012	T. YAMASAKI	TITLE GP-1670/1670F
CHECKED 4/Apr/2012	H. MAKI	名称 指示部 (卓上装備)
APPROVED 6/Apr/2012	H. Maki	外寸図
SCALE 1/4	質量 表2参照 SEE TABLE 2	NAME DISPLAY UNIT (TABLETOP MOUNT)
DMC No. C4477-G01-A	REF. No. 14-079-100G-1	OUTLINE DRAWING

表1 TABLE 1

寸法区分 (mm) DIMENSION	公差 (mm) TOLERANCE
L ≤ 50	±1.5
50 < L ≤ 100	±2.5
100 < L ≤ 500	±3



表2 TABLE 2

型式	MODEL	質量	MASS(kg±10%)
GP-1670		1.2	
GP-1670F		1.3	

注記

- 指定外の寸法公差は表1による。
- #印寸法は最小サービス空間寸法とする。
- 壁の厚さ(A)は $5 \leq A \leq 18$ とする。
取付には寸切ボルトM4×30、M4座金・ナットを使用のこと。
筐体にはネジ部を8mm以上入れないこと。

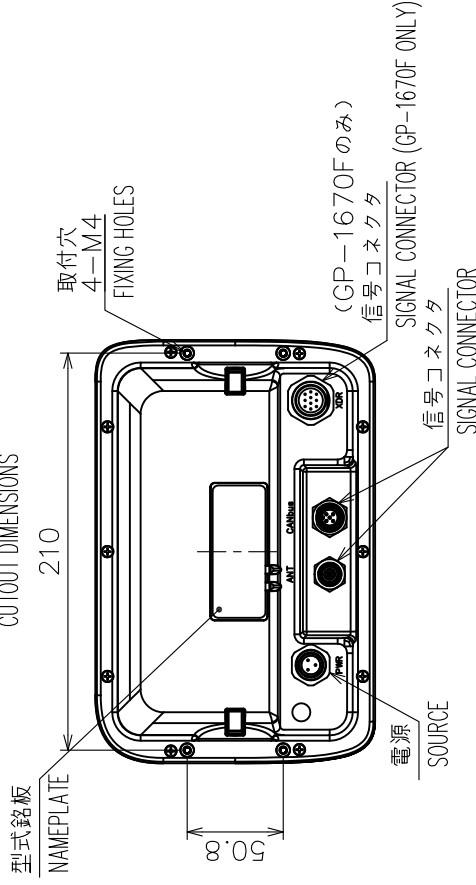
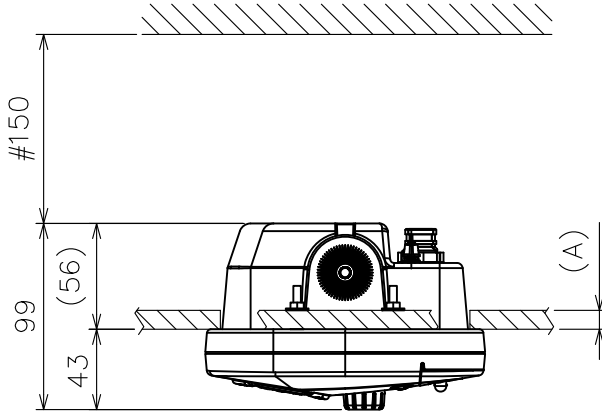
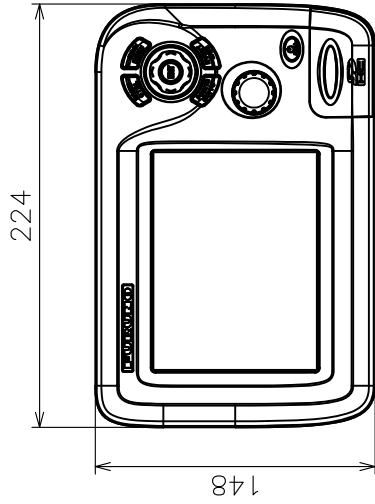
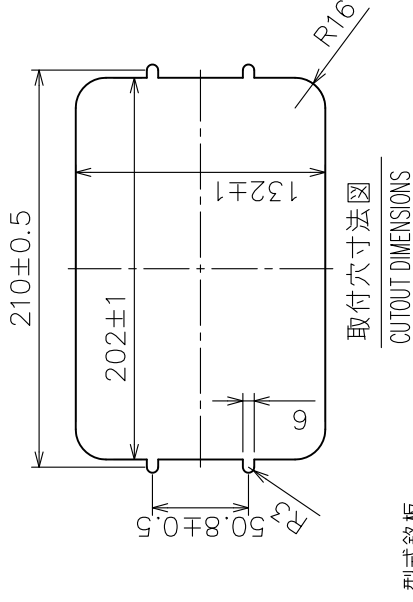
NOTE

- TABLE 1 INDICATES TOLERANCE OF DIMENSIONS WHICH IS NOT SPECIFIED.
- #: MINIMUM SERVICE CLEARANCE.
- BULKHEAD THICKNESS (A): $5 \leq A \leq 18$. USE STUD BOLT M4×30, M4 WASHER/NUT. DO NOT SCREW INTO THE UNIT 8mm OR MORE.

DRAWN	4/Apr/2012	T. YAMASAKI	TITLE	GP-1670/1670F
CHECKED	4/Apr/2012	H. MAKI	名称	指示部 (埋込装備)
APPROVED	6/Apr/2012	H. Maki	外寸図	
SCALE	1/4	質量 表2参照 SEE TABLE 2	NAME	DISPLAY UNIT (FLUSH MOUNT)
DWG.No.	C4477-G02-A	REF.No.	14-079-101G-1	OUTLINE DRAWING

表1 TABLE 1

寸法区分 (mm) DIMENSION	公差 (mm) TOLERANCE
L ≤ 50	±1.5
50 < L ≤ 100	±2.5
100 < L ≤ 500	±3

表2 TABLE 2

型式 MODEL	質量 MASS	容積率 MASS(kg±10%)
GP-1870	1.5	
GP-1870F	1.6	

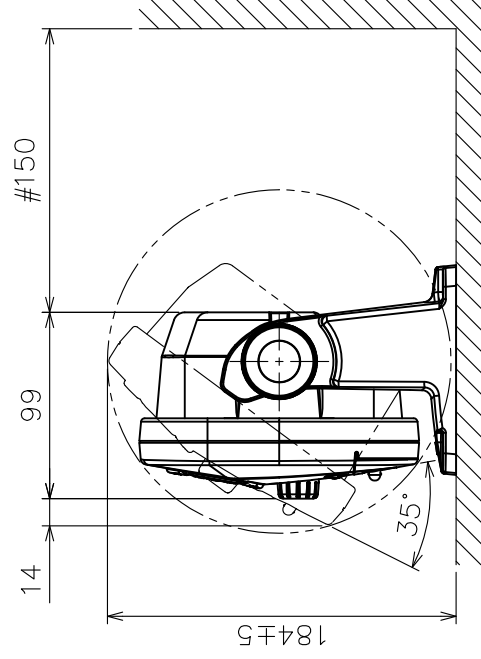
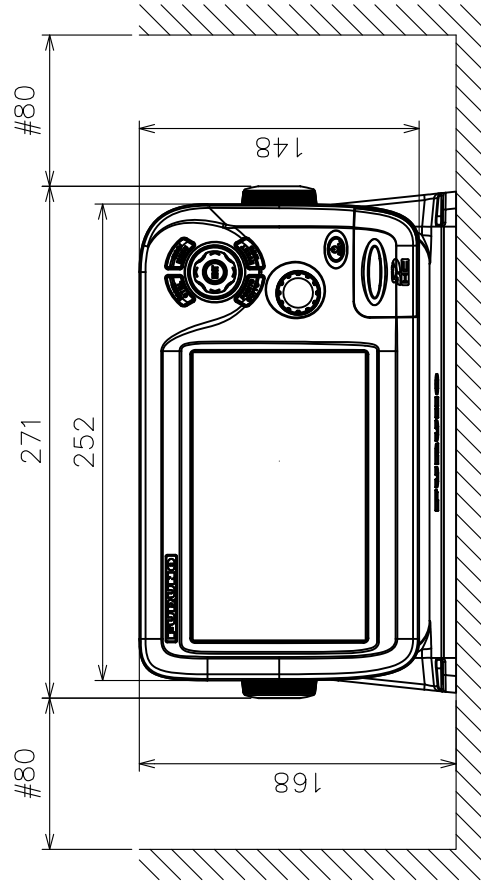
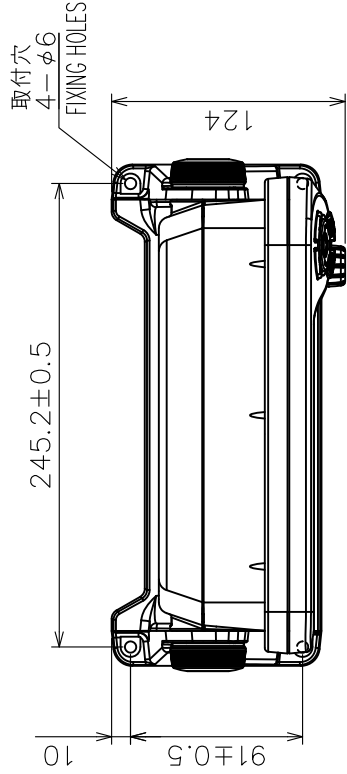
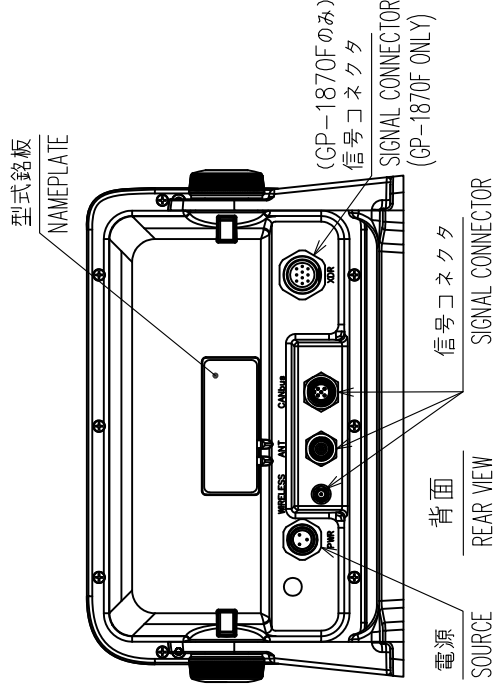

注記

- 1) 指定外の寸法公差は表1による。
- 2) #印寸法は最小サービスクリアランスとする。
- 3) 取付用ネジはトラスタップピンネジ呼び径5を使用のこと。

NOTE

1. TABLE 1 INDICATES TOLERANCE OF DIMENSIONS WHICH IS NOT SPECIFIED.
2. #: MINIMUM SERVICE CLEARANCE.
3. USE TAPPING SCREWS φ4.8x22 FOR FIXING THE UNIT.

DRAWN 4/Apr/2012	T. YAMASAKI	TITLE GP-1870/1870F
CHECKED 4/Apr/2012	H. MAKI	名称 指示部 (卓上装備)
APPROVED 6/Apr/2012	H. Maki	外寸図
SCALE 1/4	質量表参照 SEE TABLE 2	NAME DISPLAY UNIT (TABLETOP MOUNT)
DWG.No. C4479-G01-A	REF.No. 14-079-102G-1	OUTLINE DRAWING

表1 TABLE 1

寸法区分 (mm) DIMENSION	公差 (mm) TOLERANCE
L ≤ 50	±1.5
50 < L ≤ 100	±2.5
100 < L ≤ 500	±3

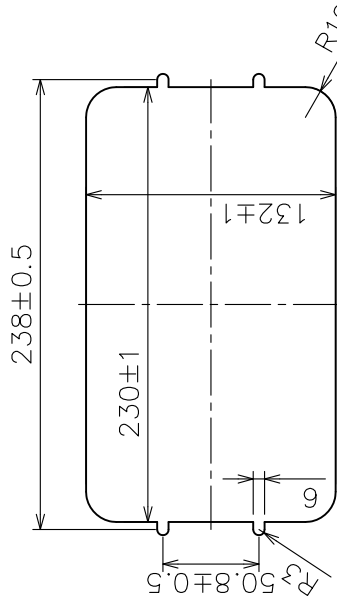
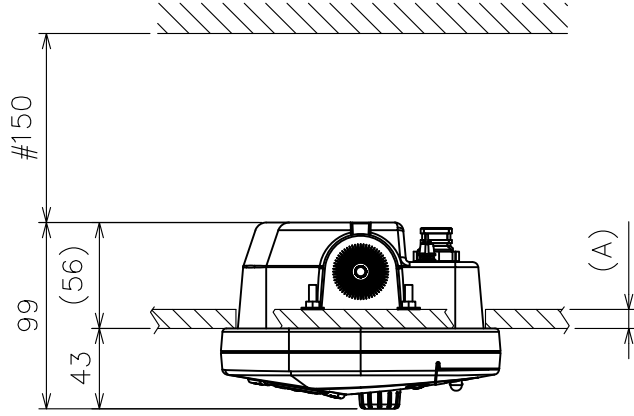
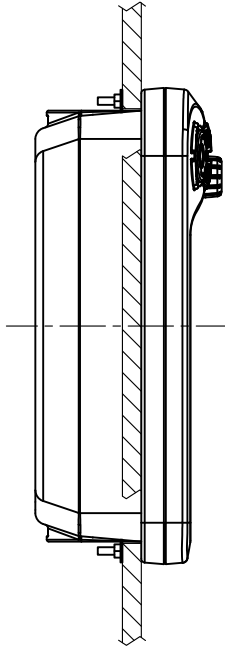

取付穴寸法
CUTOOUT DIMENSIONS

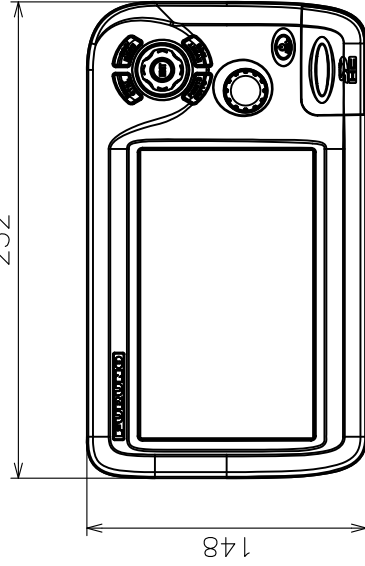

型式銘板
NAMEPLATE

238

取付穴
4-M4
FIXING HOLES

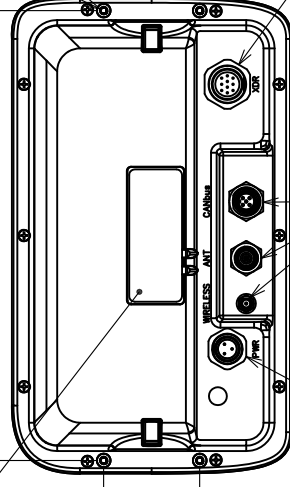

注記

- 1) 指定外の寸法公差は表1による。
- 2) #印寸法は最小サービス空間寸法とする。
- 3) 壁の厚さ(A)は $5 \leq A \leq 18$ とする。
取付にはM4×30寸切ボルト、M4座金・ナットを使用すること。
筐体にはネジ部を8mm以上入れないこと。

NOTE

1. TABLE 1 INDICATES TOLERANCE OF DIMENSIONS WHICH IS NOT SPECIFIED.
2. #: MINIMUM SERVICE CLEARANCE.
3. USE STUD BOLT M4x30, M4 WASHER/NUT FOR FIXING THE UNIT.
DO NOT SCREW INTO THE UNIT 8mm OR MORE.

表2 TABLE 2

型式	MODEL	質量	MASS(kg±10%)
GP-1870		1.3	
GP-1870F		1.5	

DRAWN	4/Apr/2012	T.YAMASAKI	TITLE	GP-1870/1870F
CHECKED	4/Apr/2012	H.MAKI	名称	指示部 (埋込装備)
APPROVED	6/Apr/2012	H. Maki	NAME	外寸図
SCALE	1/4	MASS 表を参照 SEE TABLE 2	REF.No.	14-079-103G-1
DWG.No.	C4479-G02-A		OUTLINE DRAWING	

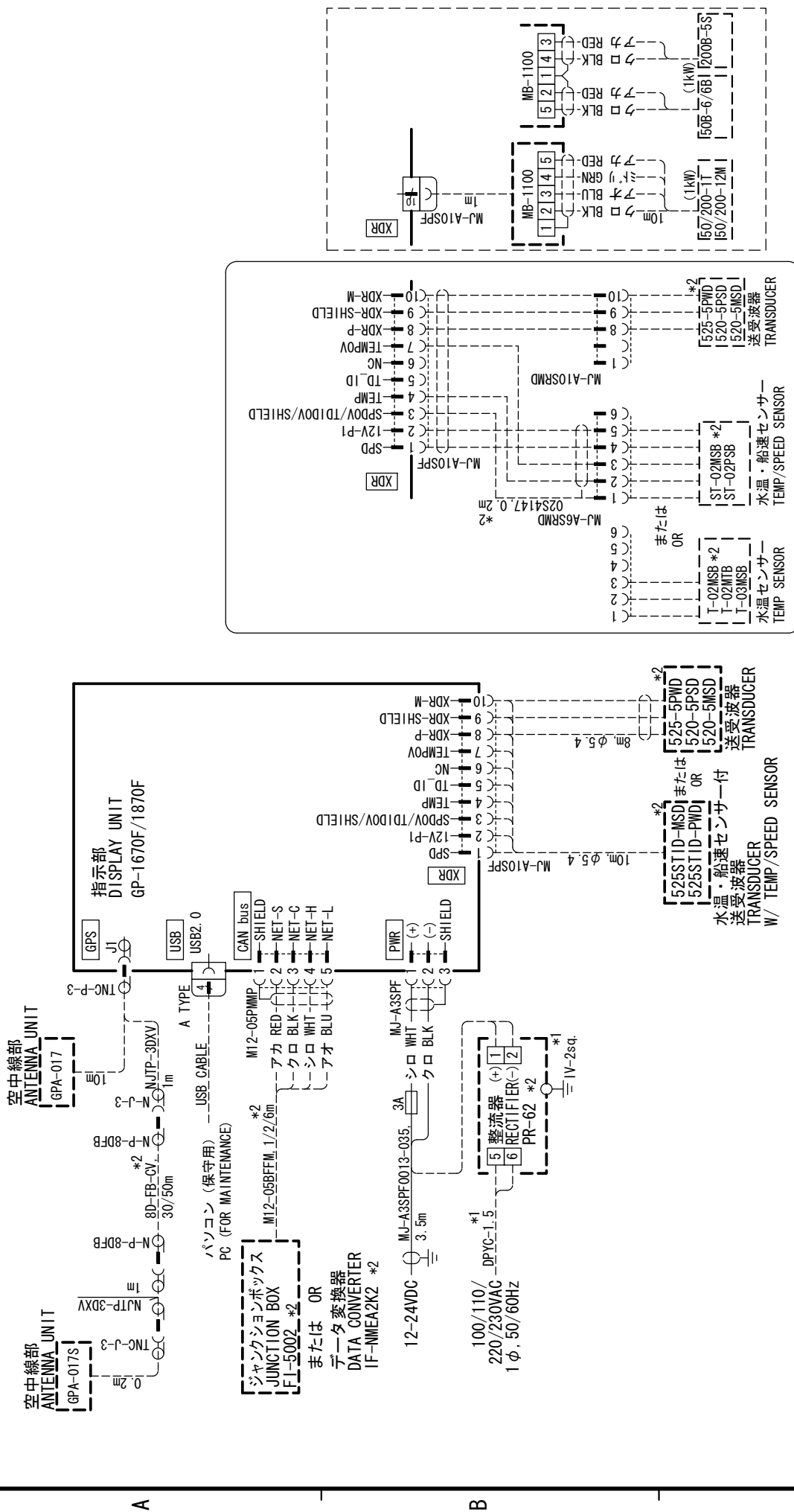

注記
 * 1) 造船所手配。
 * 2) オプション。
NOTE
 *1: SHIPYARD SUPPLY.
 *2: OPTION.

DRAWN	21/Mar/2012	T. YAMASAKI	TITLE	GP-1670F/1870F
CHECKED	21/Mar/2012	H. MAKI	名称	カラーGPSプロッタ魚探
APPROVED	22/Mar/2012	Y. NISHIYAMA	相互結線図	
SCALE	1/MASS	kg	NAME	GPS PLOTTER/SOUNDER
DWG. No.	04477-001-A		INTERCONNECTION DIAGRAM	
			REF. No.	