

## *Installation Manual* **AUTOPILOT** *Model NAVpilot-700/711/720/711C*

<b>SYSTEM CONFIGURATION</b> .....	ii	<b>3. INITIAL SETTINGS</b> .....	3-1
<b>EQUIPMENT LISTS</b> .....	iii	3.1 About Initial Settings, Menu Operation .....	3-1
<b>1. HOW TO INSTALL THE UNITS</b> .....	1-1	3.2 How to Select Language and Units, Open the Installation Menu.....	3-2
1.1 Control Unit FAP-7001/FAP-7011 .....	1-1	3.3 Display Setup .....	3-4
1.1.1 Surface mount .....	1-2	3.4 Ship's Characteristics Menu .....	3-5
1.1.2 Desktop mount .....	1-4	3.5 Dockside Setup Menu .....	3-6
1.2 Processor Unit FAP-7002 .....	1-5	3.5.1 Dockside setup for RRU.....	3-6
1.3 Rudder Reference Unit FAP-6112.....	1-7	3.5.2 Dockside setup for Fantum Feedback™ .....	3-11
1.4 Remote Controllers (option).....	1-9	3.5.3 How to set the safe helm mode and power assist mode .....	3-13
1.5 Distributor FAP-6800 (option).....	1-12	3.5.4 Confirmation of the dockside setup.....	3-16
1.6 Control Unit FAP-7021.....	1-13	3.6 CAN bus Port Setup .....	3-19
1.7 Cable Extension Kit FAP-7822 (option) .....	1-13	3.7 NMEA0183 Port Setup .....	3-20
<b>2. WIRING</b> .....	2-1	3.8 Sensor Setup.....	3-22
2.1 General Wiring.....	2-1	3.9 Universal Port Setup.....	3-23
2.2 Processor Unit .....	2-2	3.10 Sea Trial .....	3-25
2.2.1 Connections inside the processor unit .....	2-2	3.11 Data Calibration.....	3-27
2.2.2 How to fasten cables to the cable clamps.....	2-3	3.12 PARAMETER SETUP Menu .....	3-28
2.2.3 How to put wires into the connector blocks.....	2-4	3.13 AUTO OPTION Menu.....	3-32
2.2.4 How to terminate of NMEA2000 connection.....	2-5	3.14 NAV OPTION Menu .....	3-33
2.2.5 Power and motor cables.....	2-5	3.15 FISH HUNTER OPTION Menu or WIND OPTION Menu .....	3-35
2.2.6 Teleflex linear sensor .....	2-7	3.15.1 FISH HUNTER OPTION menu .....	3-35
2.2.7 CAN bus power .....	2-8	3.15.2 WIND OPTION menu .....	3-36
2.2.8 Connection to TB4.....	2-8	3.16 SYSTEM SETUP Menu.....	3-37
2.3 Control Unit.....	2-8	3.17 RC (Remote Controller) SETUP Menu....	3-38
2.4 Remote Controllers (option).....	2-9	3.18 All Clear .....	3-38
2.4.1 Example remote controller connections .....	2-10	<b>JIS CABLE GUIDE</b> .....	<b>AP-1</b>
2.4.2 Prohibited remote controller connections .....	2-11	<b>PACKING LISTS</b> .....	<b>A-1</b>
2.5 Input/Output Sentences .....	2-12	<b>OUTLINE DRAWINGS</b> .....	<b>D-1</b>
		<b>INTERCONNECTION DIAGRAM</b> .....	<b>S-1</b>
		<b>MOUNTING TEMPLATES</b>	



 **FURUNO ELECTRIC CO., LTD.**

[www.furuno.com](http://www.furuno.com)

All brand and product names are trademarks, registered trademarks or service marks of their respective holders.

**ECF**

(Elemental Chlorine Free)

The paper used in this manual  
is elemental chlorine free.

**FURUNO ELECTRIC CO., LTD.**

9-52 Ashihara-cho,  
Nishinomiya, 662-8580, JAPAN

• FURUNO Authorized Distributor/Dealer

All rights reserved. Printed in Japan

Pub. No. IME-72720-J

(REFU) NAVpilot-700 Series

A : JAN. 2010

J : OCT. 24, 2013



0 0 0 1 7 1 8 1 3 1 8



# SAFETY INSTRUCTIONS

Please read these safety instructions before you install the equipment.



## WARNING

Indicates a condition that can cause death or serious injury if not avoided.



## CAUTION

Indicates a condition that can cause minor or moderate injury if not avoided.



Warning, Caution



Prohibitive Action



Mandatory Action



## WARNING



**Turn off the power at the switchboard before beginning the installation.**

Fire or electrical shock can result if the power is left on.



**Use the proper power cable.**

Use JIS type DPY-2.5 or the equivalent. Other types can cause fire.



**Confirm that no one is near the rudder when bleeding air from oil cylinder.**

The rudder may move unexpectedly, possibly causing bodily injury.



**When connecting a geomagnetism detection type heading sensor, correct magnetic field deviation.**

If an autopilot is used without the compensation, unexpected course change may occur.



**Set REMOTE CONTROLLER 1/2 on SYSTEM SETUP menu properly according to remote controller connected.**

If not done properly, malfunction may occur. Especially, take care when setting the NFU-type remote controller.



## CAUTION



**Confirm that the power supply voltage is compatible with the voltage rating of the equipment.**

Connection to the wrong power supply can cause fire or damage the equipment.



**Observe the following compass safe distances to prevent interference to a magnetic compass:**

		Standard compass	Steering compass
Control Unit	FAP-7001	0.35 m	0.30 m
	FAP-7011	0.35 m	0.30 m
	FAP-7011C	0.50 m	0.35 m
	FAP-7021	0.35 m	0.30 m
Processor Unit FAP-7002		0.45 m	0.30 m
Remote controllers		0.30 m	0.30 m



**Separate the reversible pump at least one meter from communications equipment, communications antenna and communications cabling to prevent interference.**

# SYSTEM CONFIGURATION

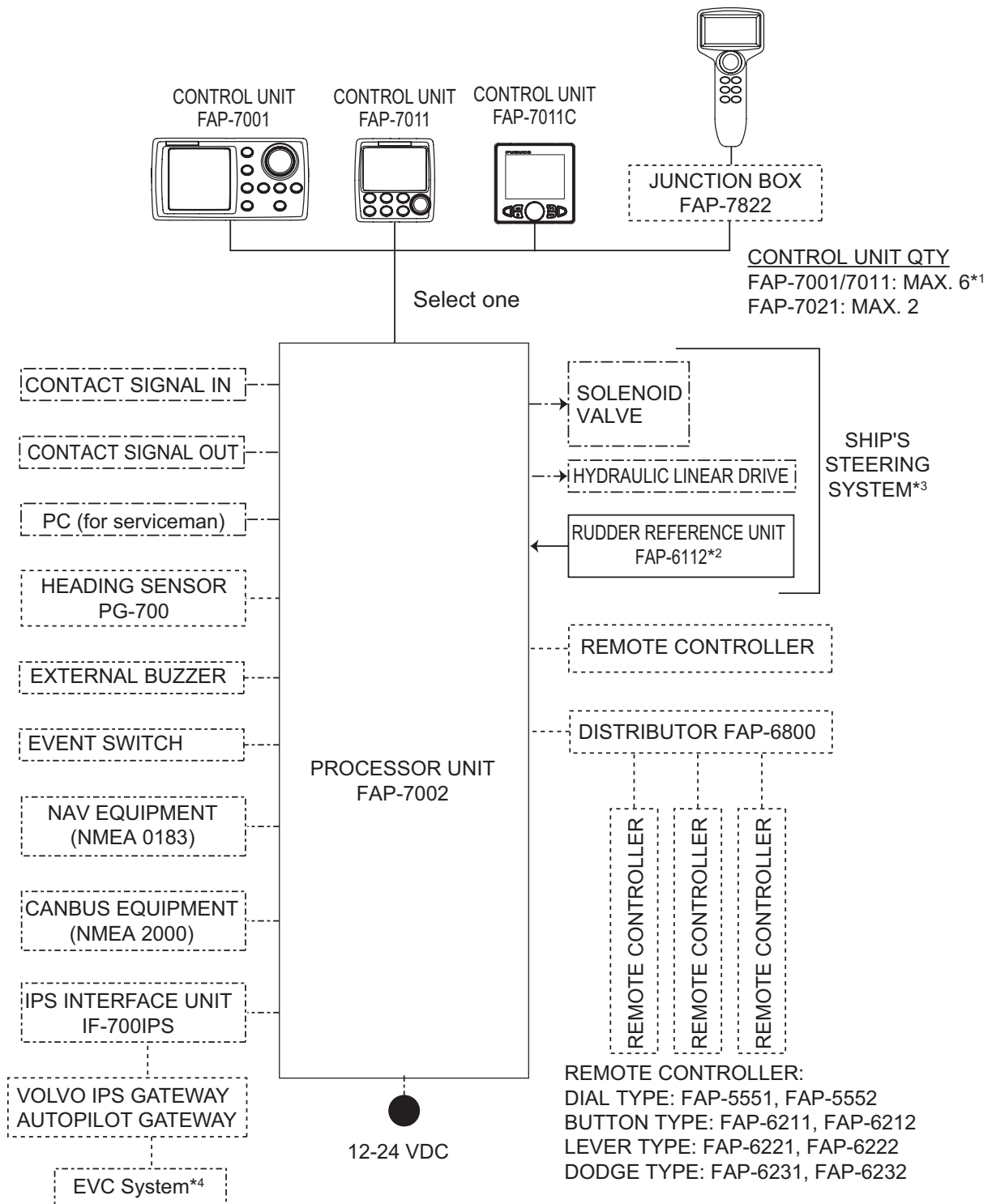

- : STANDARD
- : OPTION
- - - - : USER SUPPLY

\*1: Any combination of control units is available. For FAP-7021, connect at the end of series.

\*2: Not required for Fantum Feedback™.

\*3: Not required for the VOLVO IPS drive equipped vessel.

\*4: For the EVC system available with the NAVpilot, contact your dealer.



# EQUIPMENT LISTS

## Standard supply for NAVpilot-700

Name	Type	Code No.	Qty	Remarks
Control Unit	FAP-7001	-	1	
Processor Unit	FAP-7002	-	1	
Rudder Reference Unit	FAP-6112-200	-	1	May or may not be supplied depending on order.
Installation Materials	CP64-02900	000-016-414	1	For Control Unit, w/cable assy. BD-07AFFM-LR-150 and CP64-02901
	CP64-03101	001-082-720	1	For Processor Unit
	CP64-02601	009-001-170	1	For Rudder Reference Unit May or may not be supplied depending on order.
Spare Parts	SP64-01501	001-082-710	1	For Processor Unit, fuse
Accessories	FP64-01401	001-082-700	1	For Control Unit
VOLVO Interfece Kit	FAP-6300	000-022-971	1	May or may not be supplied depending on order.

## Standard supply for NAVpilot-711

Name	Type	Code No.	Qty	Remarks
Control Unit	FAP-7011	-	1	
Processor Unit	FAP-7002	-	1	
Rudder Reference Unit	FAP-6112-200	-	1	May or may not be supplied depending on order.
Installation Materials	CP64-03000	000-016-415	1	For Control Unit, w/cable assy. BD-07AFFM-LR-150 and CP64-03001
	CP64-03101	001-082-720	1	For Processor Unit
	CP64-02601	009-001-170	1	For Rudder Reference Unit May or may not be supplied depending on order.
Spare Parts	SP64-01501	001-082-710	1	For Processor Unit, fuse
Accessories	FP64-01401	001-082-700	1	For Control Unit
VOLVO Interfece Kit	FAP-6300	000-022-971	1	May or may not be supplied depending on order.

**Standard supply for NAVpilot-720**

Name	Type	Code No.	Qty	Remarks
Control Unit	FAP-7021	-	1	
Processor Unit	FAP-7002	-	1	
Rudder Reference Unit	FAP-6112-200	-	1	w/20 m cable
Installation Materials	CP64-03101	001-082-720	1	For Processor Unit
	CP64-02601	009-001-170	1	For Rudder Reference Unit
Spare Parts	SP64-01501	001-082-710	1	For Processor Unit, fuse
Accessories	FP64-01411	001-082-770	1	For Control Unit

**Standard supply for NAVpilot-711C**

Name	Type	Code No.	Qty	Remarks
Control Unit	FAP-7011C	-	1	
Processor Unit	FAP-7002	-	1	
Rudder Reference Unit	FAP-6112-200	-	1	May or may not be supplied depending on order.
Installation Materials	CP64-03101	001-082-720	1	For Processor Unit
	CP64-02601	009-001-170	1	For Rudder Reference Unit May or may not be supplied depending on order.
Spare Parts	SP64-01501	001-082-710	1	For Processor Unit, fuse
Sponge	TZ8103008A	-	1	For Control Unit, installation materials
Cable Assy.	BD-07AFFM-LR-150	001-081-180-10	1	
Terminator	BD-07AFFM-LR-7001	001-081-140-10	1	For Control Unit, accessory
VOLVO Interfece Kit	FAP-6300	000-022-971	1	May or may not be supplied depending on order.

## Optional supply

Name	Type	Code No.	Remarks
Control Unit	FAP-7001	-	Max. 5 optional units
	FAP-7011	-	Max. 5 optional units
	FAP-7021	-	Max. 2 optional units
	FAP-7011C	-	Max. 5 optional units
Remote Controller	FAP-5551	-	Dial type, w/connector
	FAP-5552	-	Dial type, no connector
	FAP-6211	-	Button type, w/connector
	FAP-6212	-	Button type, no connector
	FAP-6221	-	Lever type, w/connector and w/CP64-01100
	FAP-6222	-	Lever type, no connector, w/CP64-01100
	FAP-6231	-	Dodge type, w/connector
	FAP-6232	-	Dodge type, no connector
VOLVO Interface Kit	FAP-6300	000-022-971	For the IPS drive equipped vessel
IPS Inter-face unit	IF-700IPS	000-022-972	
VOLVO IPS Gateway	AUTOPILOT-GATEWAY	000-022-974	
Distributor	FAP-6800	000-090-242	For connection of three remote controllers
Terminator	BD-07AFFM-LR7001	001-081-140-10	
Cable Assy	MJ-A10SPF0001-060+	001-081-150-10	For Distributor Unit, 6 m
	MJ-A10SPF0001-120+	001-081-160-10	For Distributor Unit, 12 m
	BD-07AFFM-LR-100	001-081-170-10	For Control Unit, 10 m, connector at one end
	BD-07AFFM-LR-150	001-081-180-10	For Control Unit, 15 m, connector at one end
	BD-07AFFM-LR-200	001-081-190-10	For Control Unit, 20 m, connector at one end
	BD-07AF-07AF-LR-100	001-081-200-10	For Control Unit, 10 m, connector at both ends
	BD-07AF-07AF-LR-200	001-081-210-10	For Control Unit, 20 m, connector at both ends
	M12-05BFFM-010	000-167-965-10	CAN bus drop cable, 1 m, micro
	M12-05BFFM-020	000-167-966-10	CAN bus drop cable, 2 m, micro
	M12-05BFFM-060	000-167-967-10	CAN bus drop cable, 6 m, micro
	CB-05BFFM-010	000-167-971-10	CAN bus drop cable, 1 m, mini
	CB-05BFFM-020	000-167-972-10	CAN bus drop cable, 2 m, mini
	CB-05BFFM-060	000-167-973-10	CAN bus drop cable, 6 m, mini
T-type Connector	SS-050505-FMF-TS001	000-168-603-10	For CAN bus, micro+micro
	NC-050505-FMF-TS001	000-160-507-10	For CAN bus, mini+micro

<b>Name</b>	<b>Type</b>	<b>Code No.</b>	<b>Remarks</b>
Termination Resistor	LTWMC-05BMMT-SL8001	000-168-604-10	For CAN bus, micro, male
	LTWMN-05AMMT-SL8001	000-160-508-10	For CAN bus, mini, male
	LTWMC-05BFFT-SL8001	000-168-605-10	For CAN bus, micro, female
	LTWMN-05AFFT-SL8001	000-160-509-10	For CAN bus, mini, female
Cable Extension Kit	FAP-7822	000-016-670	
Cradle	FP64-01411	001-082-770	
Flush Mount Kit	FAP-7001-FLUSH-KIT	001-082-730	For FAP-7001
	FAP-7011-FLUSH-KIT	001-082-740	For FAP-7011
Bracket	FAP-7001-BRACKET	001-082-750	For FAP-7001, w/bracket and two knob bolts
	FAP-7011-BRACKET	001-082-760	For FAP-7011, w/bracket and two knob bolts
Rudder Reference Unit	FAP-6112-200	-	w/20 m cable
Junction Box	FI-5002	000-010-765	w/self-tapping screws
Bracket Assembly	OP64-2	009-004-030	For FAP-5551/5552
Flush Mount Kit	OP64-4	009-005-790	For FAP-6221/6222, panel type
	OP64-5	009-005-800	For FAP-6221/6222, surface type

**Notice for discontinued models**

The autopilot NAVpilot-711/720 are discontinued.

# 1. HOW TO INSTALL THE UNITS

---

**Note:** For how to install the Control Unit FAP-7011C, see the operator's manual (OME-72780).

## 1.1 Control Unit FAP-7001/FAP-7011

- The Control Unit can be installed three ways:
  - Surface mount (fixed from front panel or fixed from rear panel (FAP-7011 only))
  - Desktop mount, and
  - Flush mount (Optional kit required, instructions, supplied separately).



Control Unit-FAP-7001



Control Unit FAP-7011

Select a mounting location for the Control Unit, keeping the following in mind.

- Select a location with good ventilation.
- Shock and vibration must be the least possible.
- Use the supplied display hard cover when the system is not in use.
- Do not install the display unit under "Plexiglas" or other type of shielding material. Plexiglas can trap heat and moisture or magnify sunlight energy onto the surface of the display.
- For maintenance and checking purposes, leave space at the sides and rear of the unit and leave slack in cables. See the outline drawing for recommended maintenance space.
- Observe the compass safe distances shown in the safety instructions on page i to prevent interference to a magnetic compass.

## 1. INSTALLATION

### 1.1.1 Surface mount

There are two types of surface mounts: Fasten from front panel and fasten from rear panel (FAP-7011 only).

#### **How to fasten Control Unit from front panel (FAP-7001/FAP-7011)**

1. Using the surface mount template at the back of this manual, open a mounting hole in the installation site.
2. Detach the front panel together with the keypad assy. Attach the sponge (supplied) to the rear of display unit.
3. Set the Control Unit to the mounting hole, and fasten the unit with four self-tapping screws (3x20, supplied).
4. Attach the front panel and keypad assy. to the Control Unit.

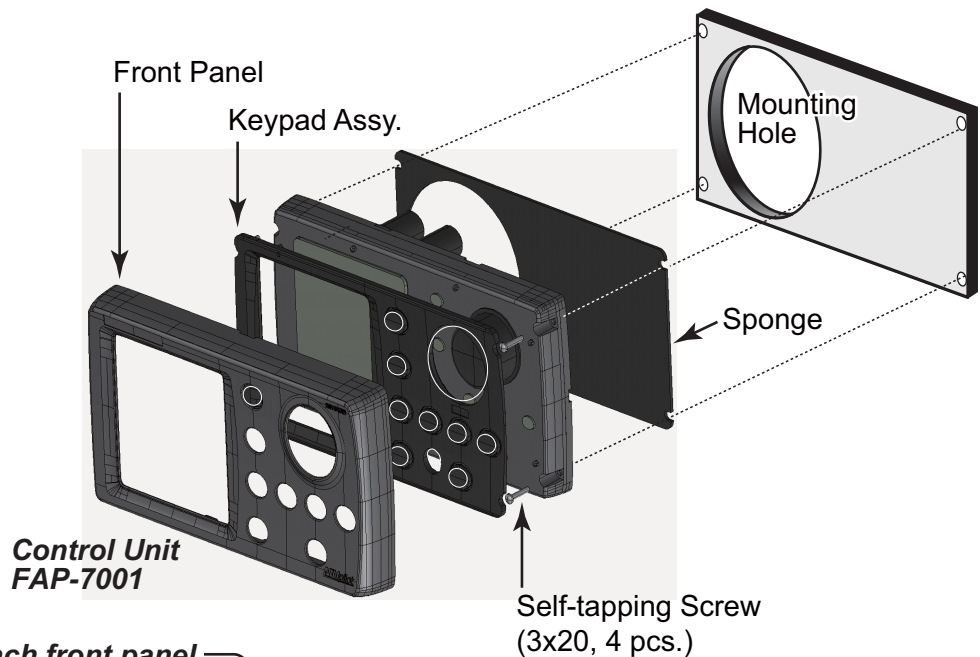

#### **How to detach front panel**

Procedure is similar for FAP-7001.



1. Set remover to notch on upper side of unit.
2. Pull remover to raise panel slightly.
3. Similarly use remover to raise panel at lower side.
4. Detach panel with hands.

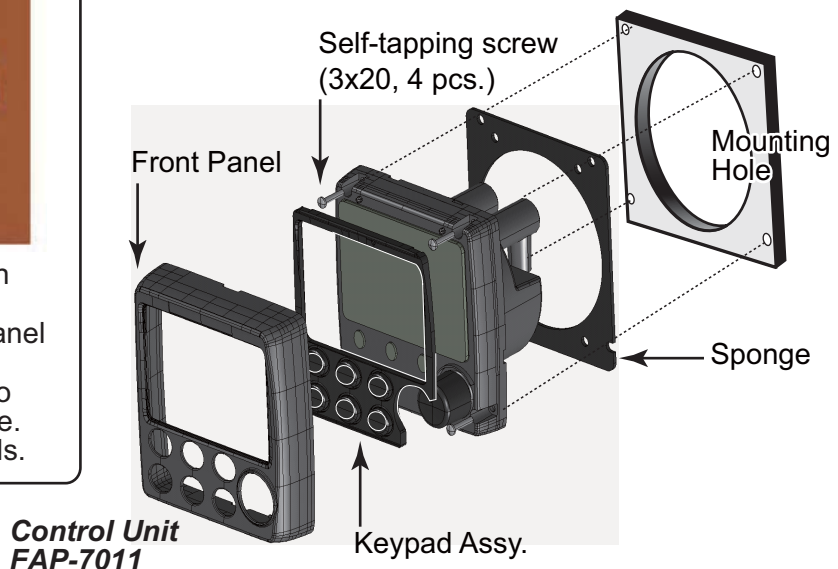

**How to fasten Control Unit from rear panel (FAP-7011 only)**

1. Using the surface mount template at the back of this manual, open a mounting hole in the installation site.
2. Set studs (M3x40, 2 pcs, supplied) in the holes marked in the illustration below. (Use only the studs supplied.)

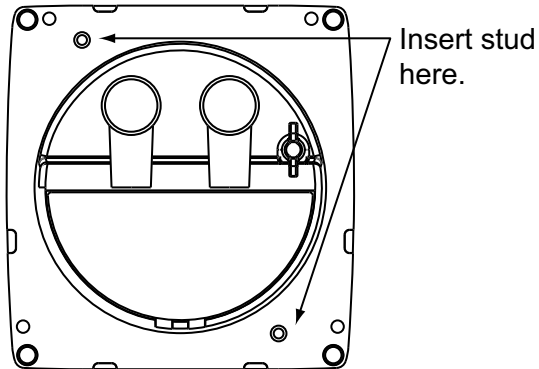

3. Set the unit to the mounting hole. Fasten the unit with the flat washers, spring washers and wing nuts (supplied).

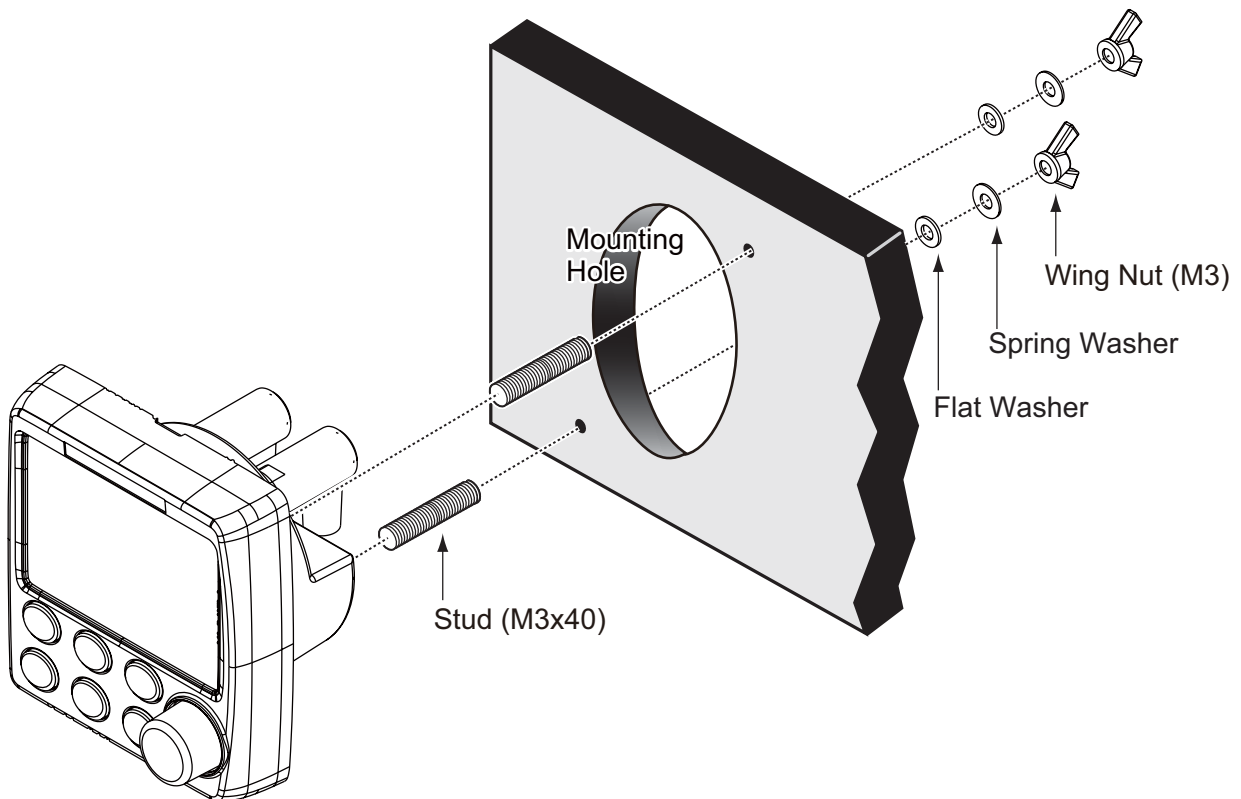

## 1. INSTALLATION

### 1.1.2 Desktop mount

Use the optional bracket installation kit to install the Control Unit on a desktop or the over-head.

#### **Bracket installation kit for FAP-7001**

Type: FAP-7001-BRACKET, Code No.: 001-082-750

Name	Type	Code No.	Qty
Bracket	64-028-1201-1	100-352-221-10	1
Connecting plate	64-028-1201-1	100-356-381-10	1
Knob	64-028-1203-0	100-352-240-10	2
Self-tapping screw	4x16	000-162-605-10	4
Pan head screw	M3x12	000-163-809-10	4
Liner	64-026-1033	100-321-340-10	2

#### **Bracket installation kit for FAP-7011**

Type: FAP-7011-BRACKET, Code No.: 001-082-760

Name	Type	Code No.	Remarks
Bracket	64-028-3201-1	100-352-281-10	1
Connecting plate	64-028-3202-1	100-356-451-10	1
Knob	64-1028-1203-0	100-352-240-10	2
Self-tapping screw	4x16	000-162-605-10	4
Pan head screw	M3x12	000-163-809-10	4
Liner	64-026-1033	100-321-340-10	2

#### **Procedure**

The procedure shown below shows how to install the FAP-7001. The procedure for the FAP-7011 is similar.

1. Fasten the bracket to the mounting location with four self-tapping screws (supplied with option).
2. Detach the front panel and keypad assy., following the instructions provided.
3. Attach the connecting plate at the back of the Control Unit with four pan head screws (supplied).
4. Screw knob bolts in connection plate, set the unit to the bracket, and tighten the knob bolts.
5. Attach the front panel and keypad assy.



6. Attach the hard cover to protect the LCD.

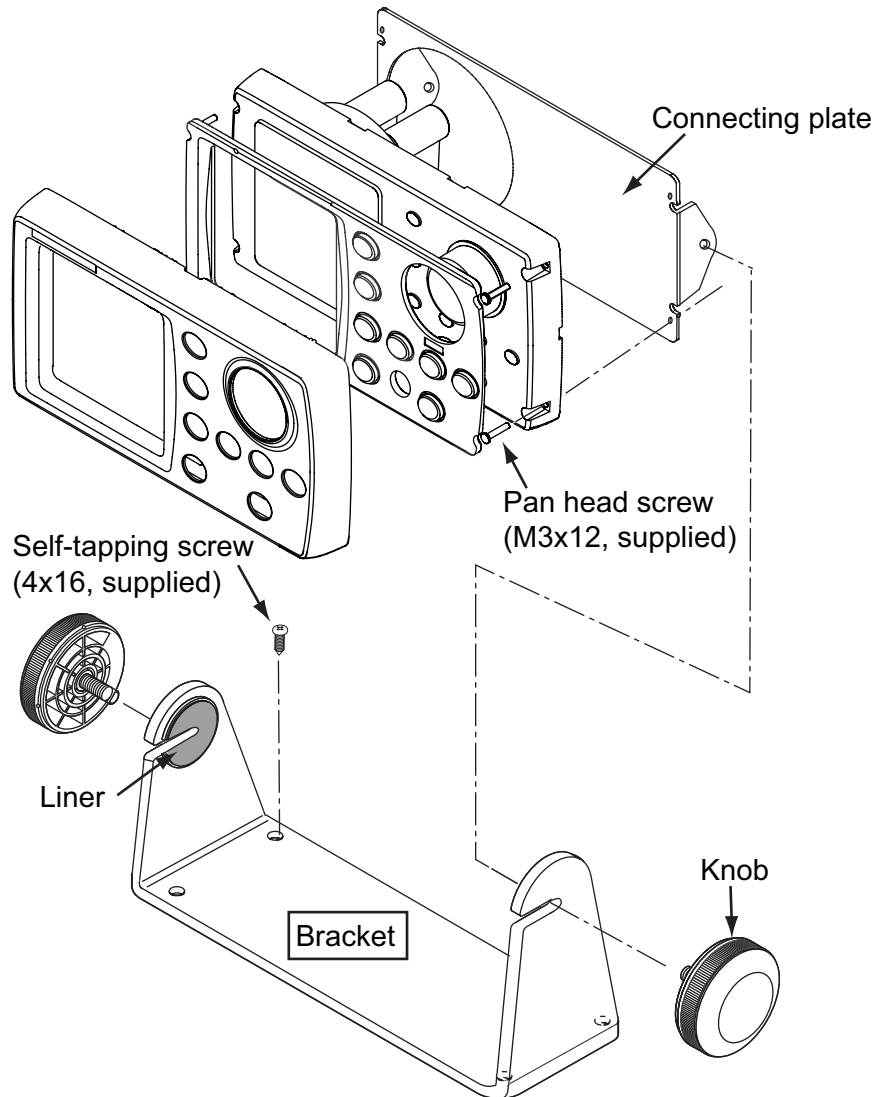

## 1.2 Processor Unit FAP-7002

This unit can be installed on a desktop or on a bulkhead. Select a mounting location considering the following points:

- Install the unit away from direct sunlight and water splash.
- Select a location where temperature and humidity are moderate and stable.
- Consider the length of the cable connected between the Processor Unit and other units.
- Install the unit where you can easily remove the cover and access controls and connectors.
- For the installation on a bulkhead, make sure the mounting location is strong enough to support the unit under the pitching and rolling normally found on the boat.
- To prevent interference, separate the processor unit and its cables at least one meter from communications equipment, communications antennas and cables for communications equipment.

## 1. INSTALLATION

- Make sure there are no objects near the vent.
- Leave enough space around the unit for maintenance and servicing. The recommended maintenance space appears in the outline drawing at the back of this manual.
- Observe the compass safe distances shown in the safety instructions on page i to prevent interference to a magnetic compass.

Install the unit as follows:

**Tabletop:** Fasten with four self-tapping screws.

**Bulkhead:** Screw in two self-tapping screws for the upper side. Leave approximately 5 mm of the screws exposed. Hang unit on screws and tighten screws. Screw in two self-tapping screws for lower side and tighten.

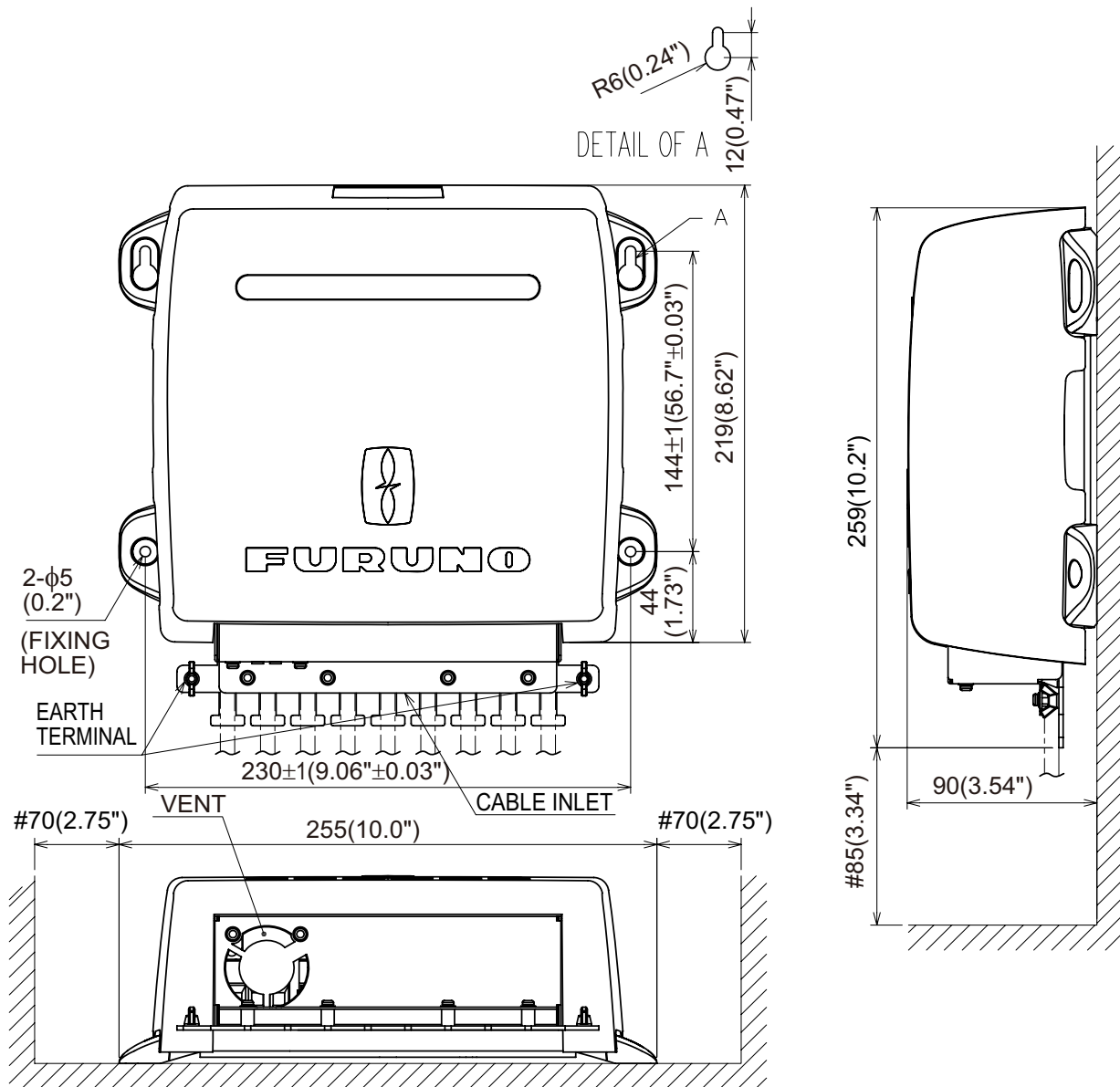

## 1.3 Rudder Reference Unit FAP-6112

**Note 1:** This unit is not required for Fantum Feedback™. For details of Fantum Feedback™, see “Fantum Feedback™” (page 1-8).

- Leave sufficient space around all moving parts.
- The unit must be fastened to the rudder as shown below, where the following conditions are met:  
 $350 \text{ mm}(13.8\text{'}) < Y2 < 540 \text{ mm}(21.3\text{'})$   
 $X1 = X2$   
 $Y1 = Y2$

Use four self-tapping screws (supplied) to fasten the rudder reference unit.

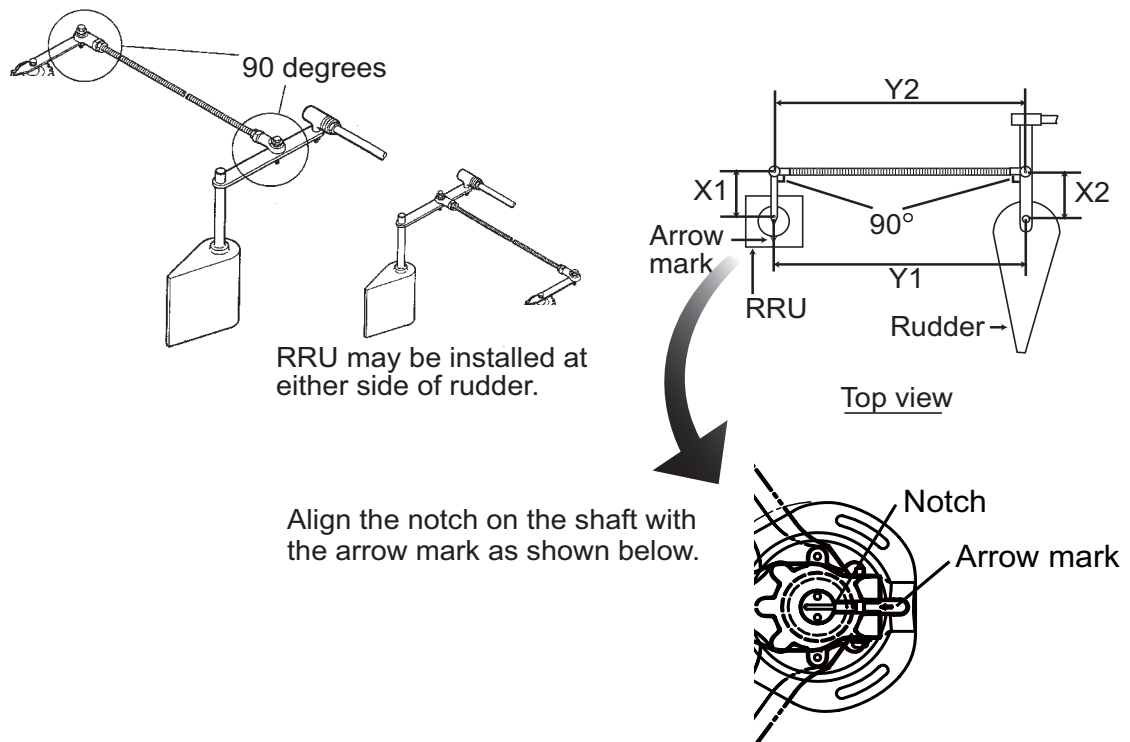

**After mounting the RRU unit adjust it as follows:**

1. Center the rudder.
2. With the rudder centered, check if the notch is aligned with the arrow mark. If it is, no further adjustment is necessary. If not, go to step 3.
3. Loosen the screw on the arm of the RRU then align notch with the arrow mark.
4. Tighten the screw.

**Relationship between reversing pump flow rate and steering cylinder capacity**

The table below shows a rough guideline to determine the proper reversing pump flow rate to match with the hydraulic steering cylinder capacity. Your experience with specific boat designs may cause you to select a pump/cylinder relationship outside of the range of these guidelines.

Pump spec.	Hardover to Hardover is 70°	Hardover to Hardover is 90°
1.0 cu. in./sec. pump	5.85 to 17.5 cu. in.	7.5 to 22.5 cu. in.
1.6 cu. in./sec. pump	9.36 to 28.0 cu. in.	12.0 to 36.0 cu. in.

If the hydraulic cylinder capacity is much smaller than the recommended values in the table, the rudder turning speed may be too fast for the pilot to deliver proper performance. The rudder deadband will decrease and the NAVpilot may not apply enough voltage for the pump motor to start because the applied "duty cycle" will be too low.

If the hydraulic cylinder capacity is much larger than the recommended values in the table, the rudder turning speed may be too slow to allow the NAVpilot to control the boat effectively.

**Fantum Feedback™**

Fantum Feedback™ means the NAVpilot is controlled without the rudder reference unit. For Fantum Feedback™, keep the following in mind.

- The ship motor is outboard.
- The length of the ship is between 20 ft and 40 ft.
- The [DRIVE UNIT SELECTION] should be set to [REVERSIBLE 24V (or 12V)] or [SAFE HELM 24V (or 12V)].

The functions and modes shown below are not available.

- FU dodge mode
- FishHunter™ mode
- Wind mode
- Remote controllers

## 1.4 Remote Controllers (option)

Two remote controllers may be connected to the Processor Unit. To connect three NFU- (Non-Follow Up) type remote controllers (button and lever) to the Processor Unit, connect them via the optional Distributor FAP-6800.

Keep the remote controllers away from areas subject to rain and water splash.

**Note:** For Fantum Feedback™, the remote controller can not be connected.

### **Dial-type remote controller FAP-5551/FAP-5552**

Fasten these remote controllers to a bulkhead. They can also be mounted on the bulk-head by using the optional bracket assembly OP64-2 (Code No.: 009-004-030).

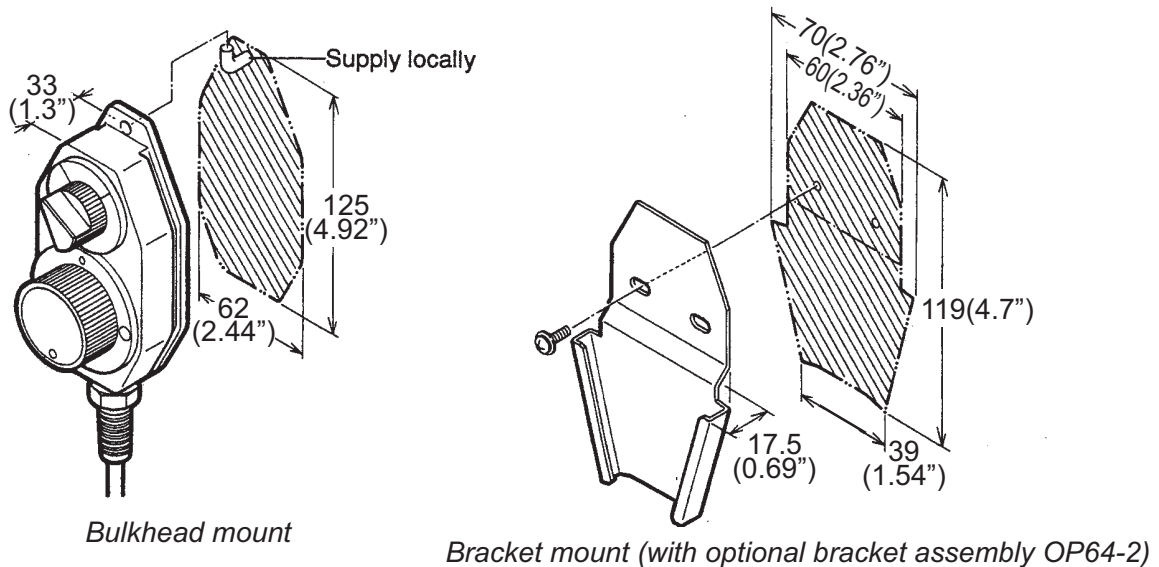

*FAP-5551, bulkhead, bracket mount*

For handheld operation in the opposite direction, reverse the switch and dial blocks so that the dial is readable. To do this, loosen the four screws shown below. Note that the switch and dial blocks are inserted into the controller body with O-rings. Be careful not to damage them.

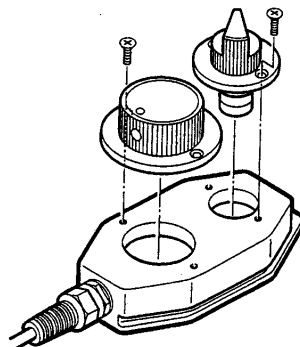

*How to reverse the switch and dial blocks*

1. INSTALLATION

**Button-type remote controller FAP-6211/6222**

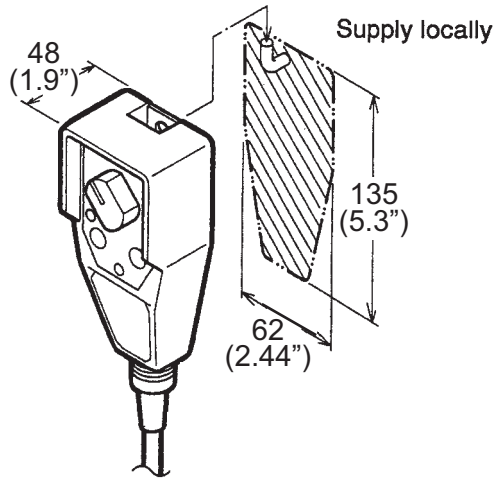

**Lever-type remote controller FAP-6221/6222**

Allow sufficient space around the unit for maintenance.

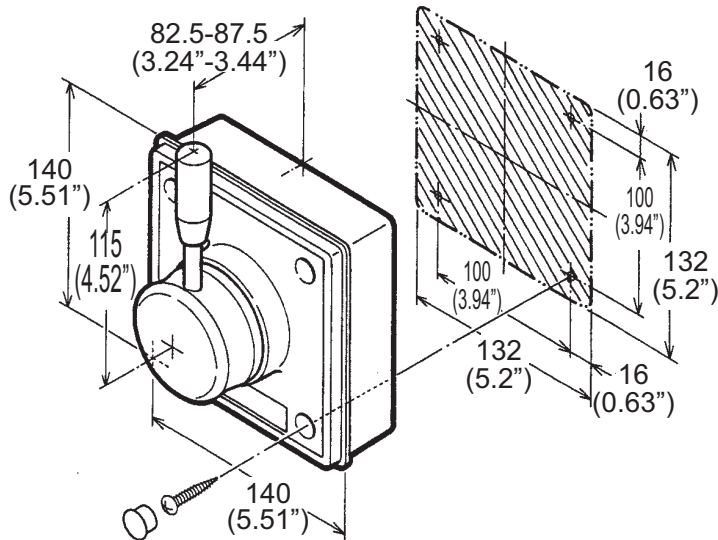

To mount the FAP-6221/6212 in a panel, the optional flush mount kit OP64-4 or OP64-5 is required.

*Flush mount kit OP64-4 (Code no. 009-005-790)*

Name	Type	Code No.	Qty
Panel frame	OP64-4	009-006-170	1
Rubber ring	64-015-4524	100-145-111-10	1
Hex. nut	M4	000-167-488-10	4
Flat washer	M4	000-167-455-10	4
Spring washer	M4	000-167-405-10	4

*Flush mount kit OP64-5 (Code no. 009-005-800)*

Name	Type	Code No.	Qty
Fixing plate	OP64-5	009-006-200	1
Rubber ring	64-015-4524	100-145-111-10	1
Hex. nut	M4	000-167-488-10	4
Spring washer	M4	000-167-405-10	4
Hex. bolt	M4x35	000-162-861-10	4

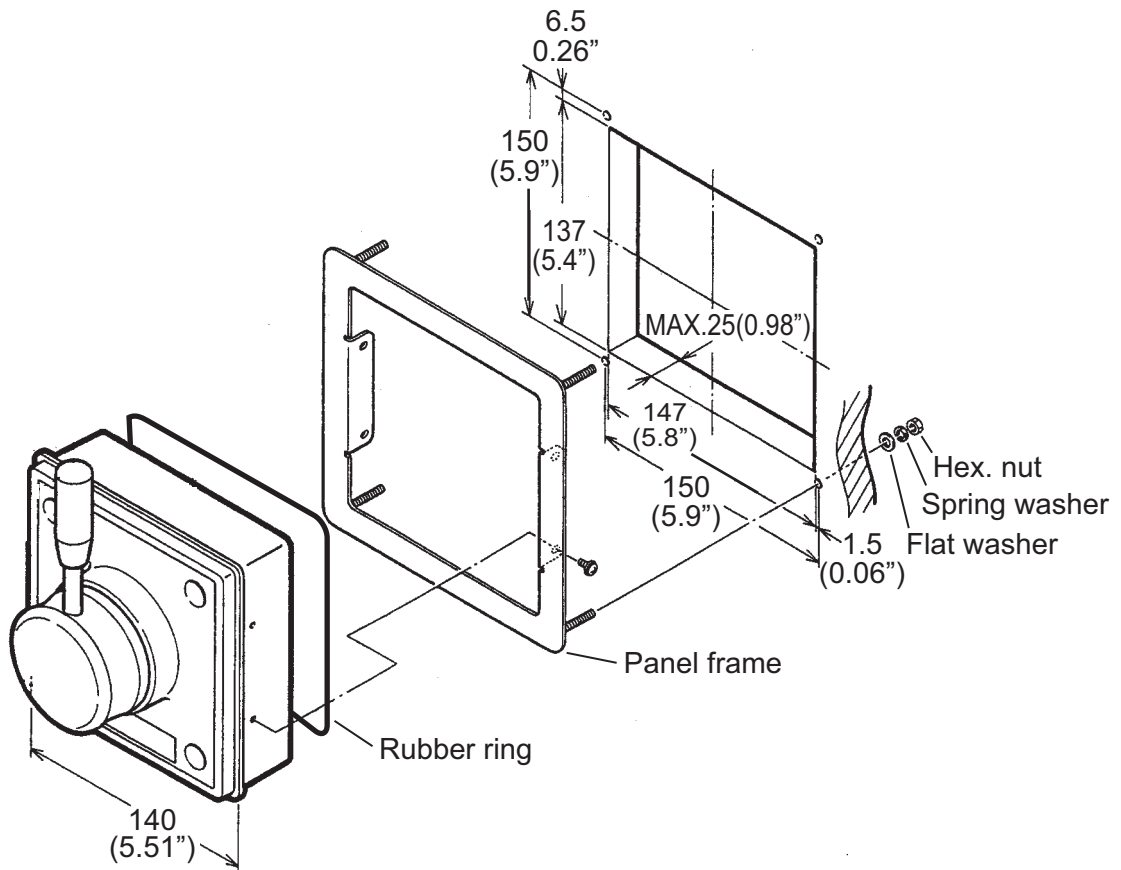

*How to flush mount the FAP-6221 with flush mount kit OP64-4*

## 1. INSTALLATION

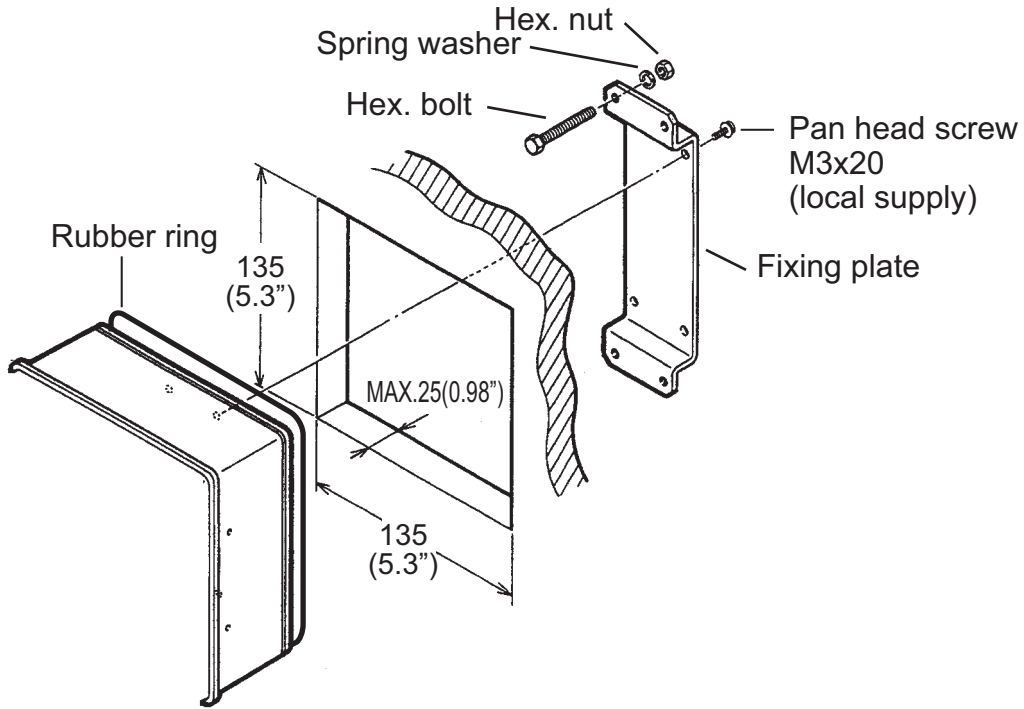

*How to flush mount the FAP-6221 with flush mount kit OP64-5*

### 1.5 Distributor FAP-6800 (option)

Use the Distributor to connect three Non-Follow Up-type remote controllers to the Processor Unit. Fix the unit to the mounting location with wood screws. For added support, use nuts, bolts and washers (all local supply) instead of the wood screws.

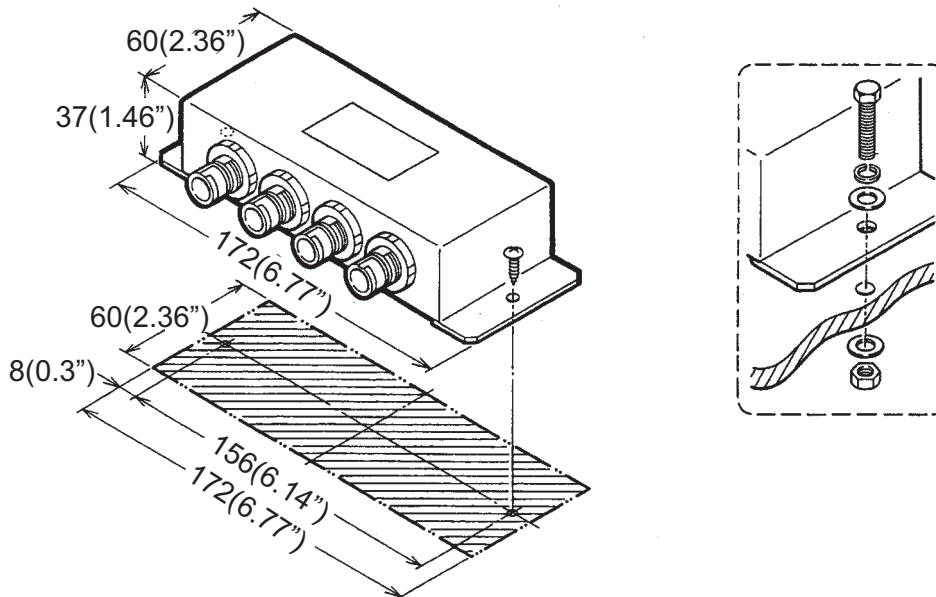



## 1.6 Control Unit FAP-7021

The Handheld Control Unit FAP-7021 can be mounted on the bulkhead or desktop using the cradle.

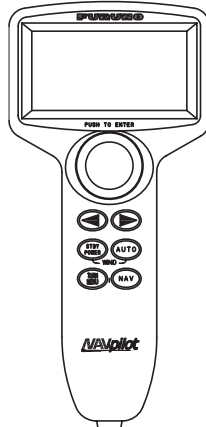

When selecting a location for the Control Unit, keep the following in mind.

- Mount the unit where shock and vibration are minimal.
- Do not install the display unit under "Plexiglas" or other type of shielding material. Plexiglas can trap heat and moisture or magnify sunlight energy onto the surface of the display.
- Follow the compass safe distances shown in the safety instructions on page i to prevent interference to a magnetic compass.

For the cradle mount, fix the cradle to the mounting location with four self-tapping screws (4x20, supplied), referring to the outline drawing for mounting dimensions. Put the Control Unit in the cradle.

## 1.7 Cable Extension Kit FAP-7822 (option)

The Control Unit FAP-7021 comes with a 10 m cable. If the cable is not long enough, use the Cable Extension Kit FAP-7822, which provides for extension of the cable an additional 10 m.

Type: Cable Extension Kit FAP-7822 Code No.: 001-082-780

Name	Type	Code No.	Qty
Connector fixing box	64-027-1011-2	100-327-882-10	1
Label	64-027-1012-1	100-327-891-10	1
Self-tapping screw	4x20	000-158-850-10	4
Cable	BD-07PM-07AF-LR-100	000-172-016-10	1

Fix the Connector Fixing Box with four self-tapping screws (4x20, supplied). Refer to the outline drawing for mounting dimensions.

**Note 1:** When the Control Unit is not connected, attach the terminator (supplied) to the Connector Fixing Box.

**Note 2:** To connect the extension cable to the Processor Unit, remove the connector.

This page is intentionally left blank.

# 2. WIRING

## 2.1 General Wiring

All units are connected to the Processor Unit. Separate the cables as far as possible from the cables that transmit radio frequency or pulsed signals. At least one meter separation is recommended.

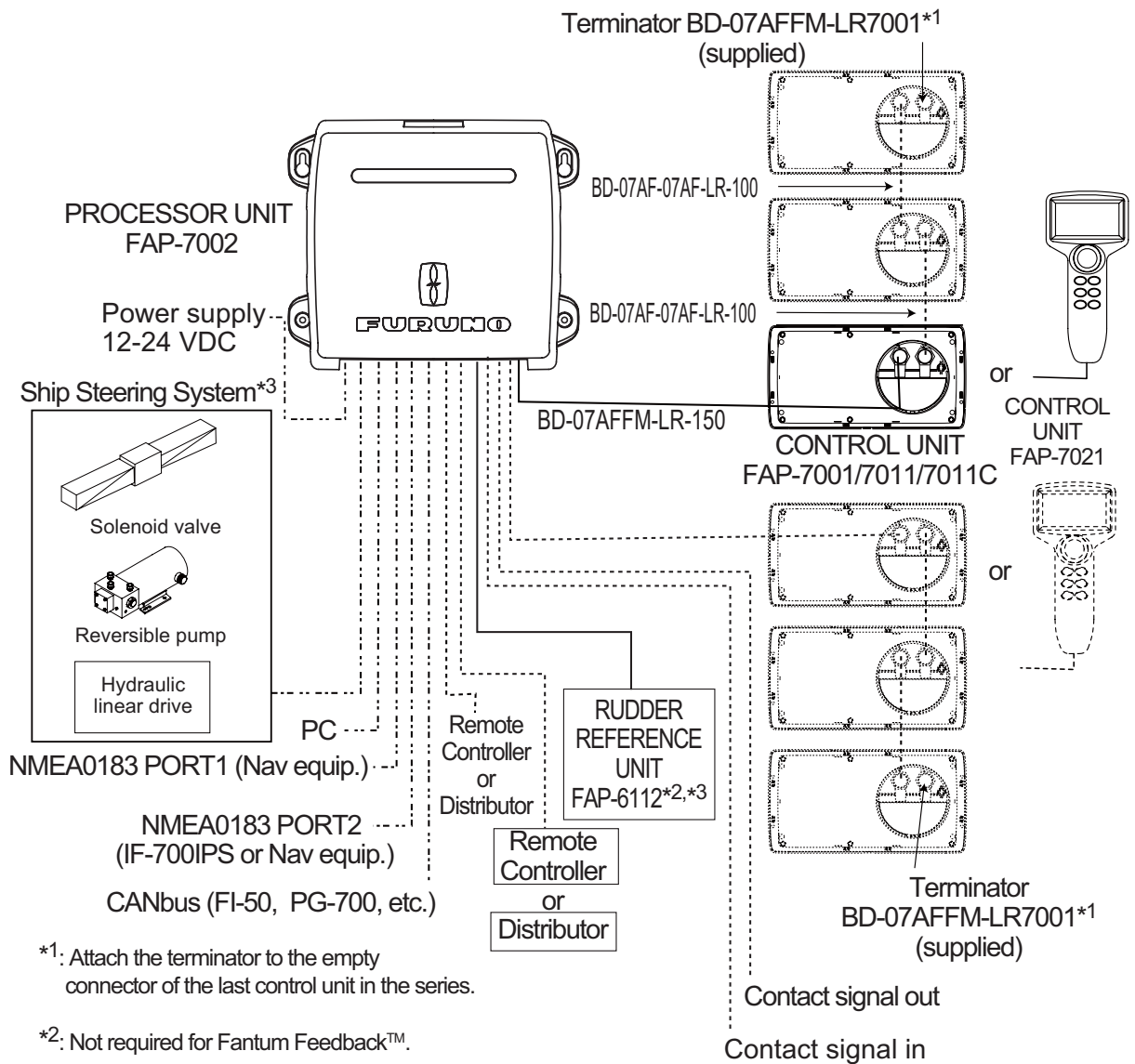

\*1: Attach the terminator to the empty connector of the last control unit in the series.

\*2: Not required for Fantum Feedback™.

\*3: Not required for the IPS drive.

## 2.2 Processor Unit

All cables are connected in the Processor Unit. To connect the FAP-7021 and FAP-6112 to the Processor Unit directly, remove the connector at the end of their cables.

### 2.2.1 Connections inside the processor unit

Pins are “numbered” from left to right, in ascending order. See the inset in the figure below for details.

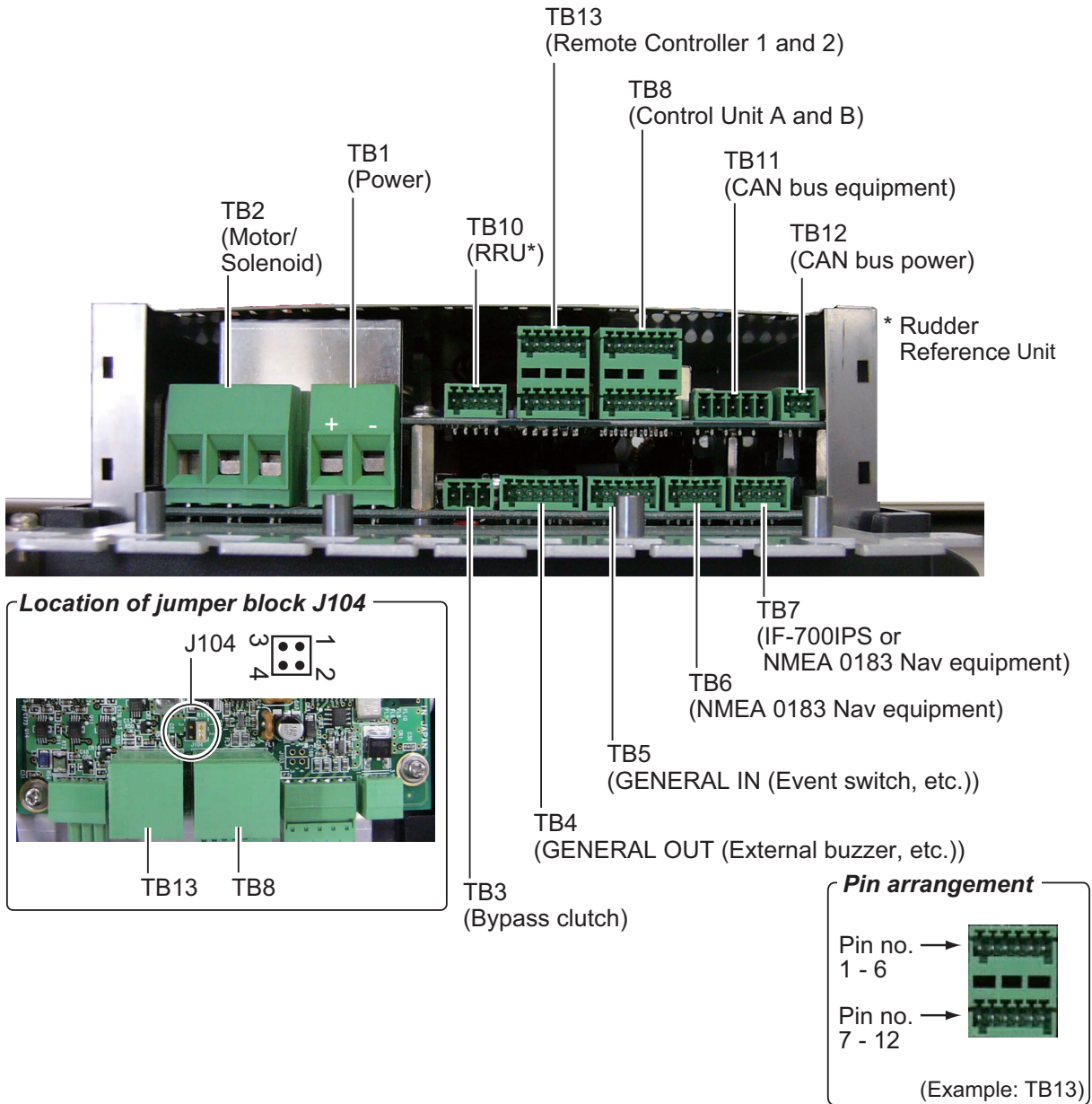

## 2.2.2 How to fasten cables to the cable clamps

Fasten the cables to the processor unit as shown below. There is no specified order to fasten the cables.

1. Remove the outside cover:
  - 1) Hold the right and left sides of the cover.
  - 2) Pull the cover outward and lift to remove.
2. Remove the four screws marked with circles in the figure shown below.

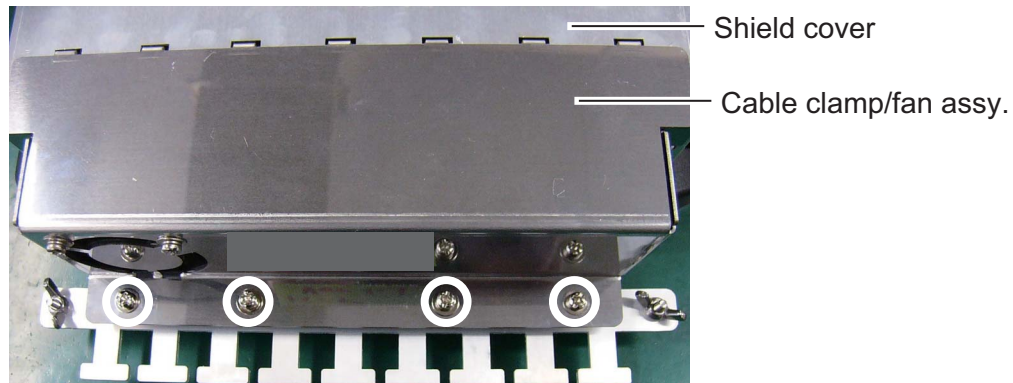

3. Separate the cable clamp/fan assy from the shield cover as shown in the figure below. Open the assembly carefully to prevent damage to the cable connected to the fan.
4. Disconnect the fan connector.

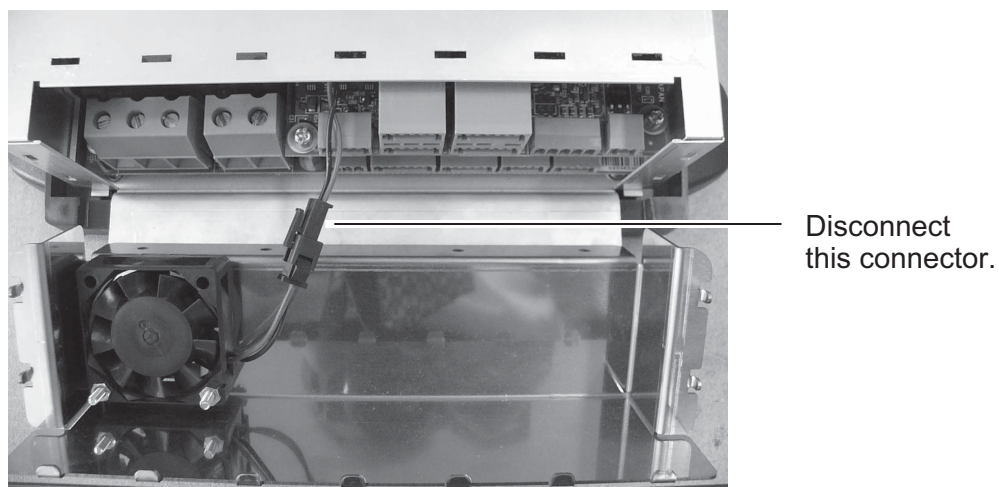

5. Twist cable cores then put the cores into their correct connector blocks. (See the next page for how to put wires into a connector block.)
6. For the NMEA cable, wind vinyl tape around the cable cores.

## 2. WIRING

7. Fasten a cable tie (supplied) to a cable and the "clamp leg".

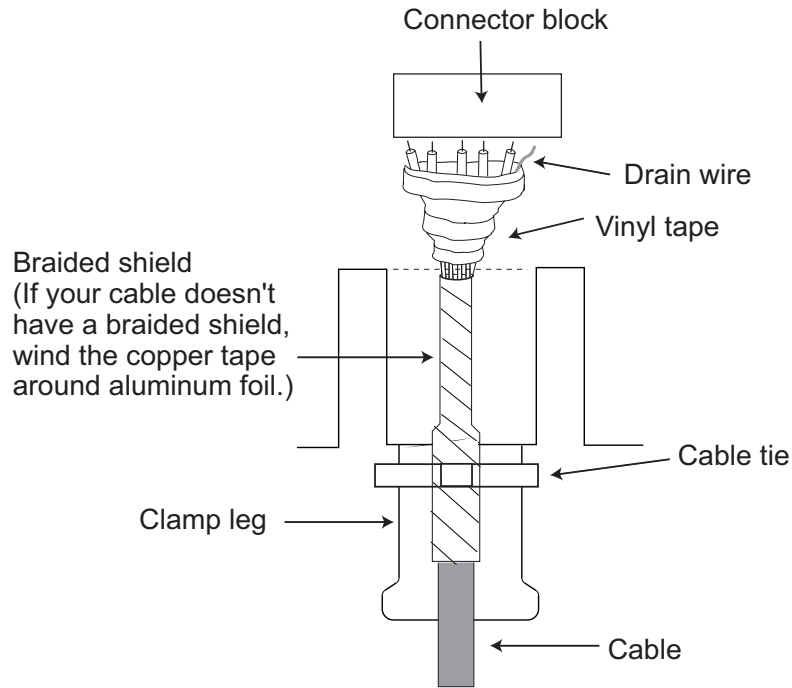

8. Connect the fan connector.

9. After you have connected all equipment, fasten the cable clamp/fan assy.

### 2.2.3 How to put wires into the connector blocks

The cables are connected to their connector blocks inside the Processor Unit. Open the unit and put cables into the connector blocks as shown in the figure below.

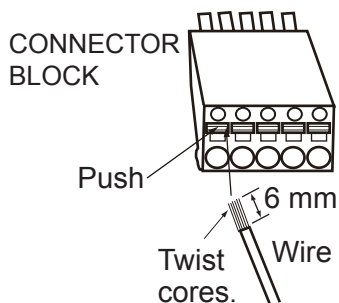

#### How to put wire into connector block

1. Remove shield of wire by 6 mm.
2. Twist core.
3. Push spring-loaded catch with slotted-head screwdriver.
4. Insert core into hole.
5. Release screwdriver.
6. Pull wire to confirm it is securely inserted.

**Note:** To connect two Control Units (to TB8 and TB9), change the position of the jumper block J104 from #1-2 to #3-4. (See the illustration on page 2-2 for location.) For single Control Unit, use TB8 and set J104 at position #1-2.

### 2.2.4 How to terminate of NMEA2000 connection

When the termination of NMEA2000 connection is needed in the NAVpilot, attach the resistor assembly (supplied as installation materials) to the NMEA2000 cable in the processor unit.

Twist the lead wire of the resistor assembly to the NMEA2000 cable, and solder them as below.

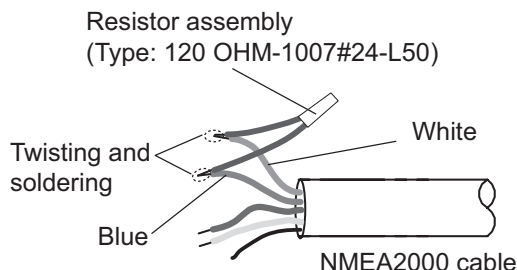

### 2.2.5 Power and motor cables

For the power cable and motor line cable, see the table below to select cables. Connect the power cable to a breaker that has a rating acceptable to the motor.

Rated current of the motor	25 A		10 A	
	Section of core(mm <sup>2</sup> )	AWG	Section of core(mm <sup>2</sup> )	AWG
3 m or less	2.5	12	1.0	16
6 m or less	4	10	1.25	16
10 m or less	6	8	2	14
16 m or less	10	6	4	10

- The thickness of the cables varies with the rated current of the motor. The table shows the specifications for 10 or 25 A motor.
- Use single core wire or stranded wire. (For stranded wire the max. no of wires is seven).
- Do not twist cores to prevent them from disconnecting.

### How to connect a reversible pump

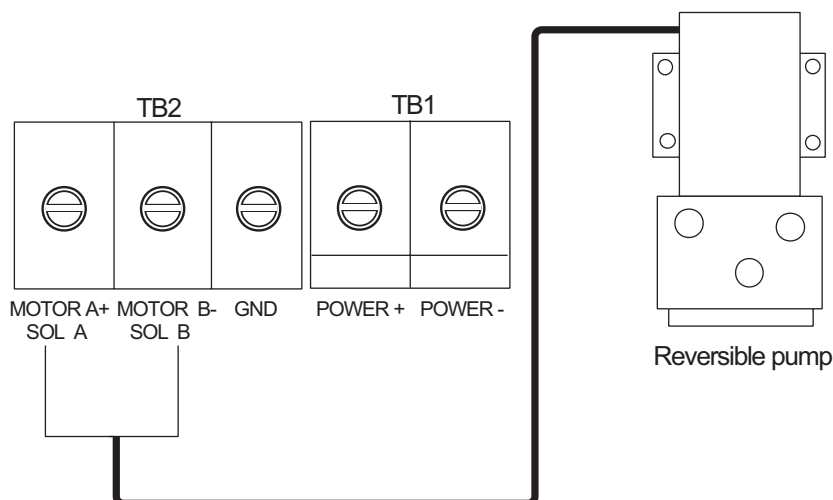

**How to connect a solenoid drive**

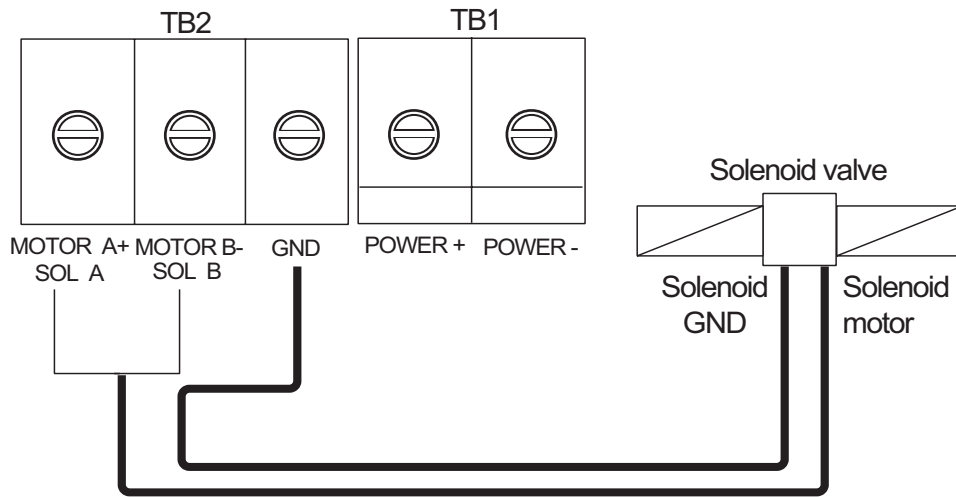

**How to connect a hydraulic linear drive**

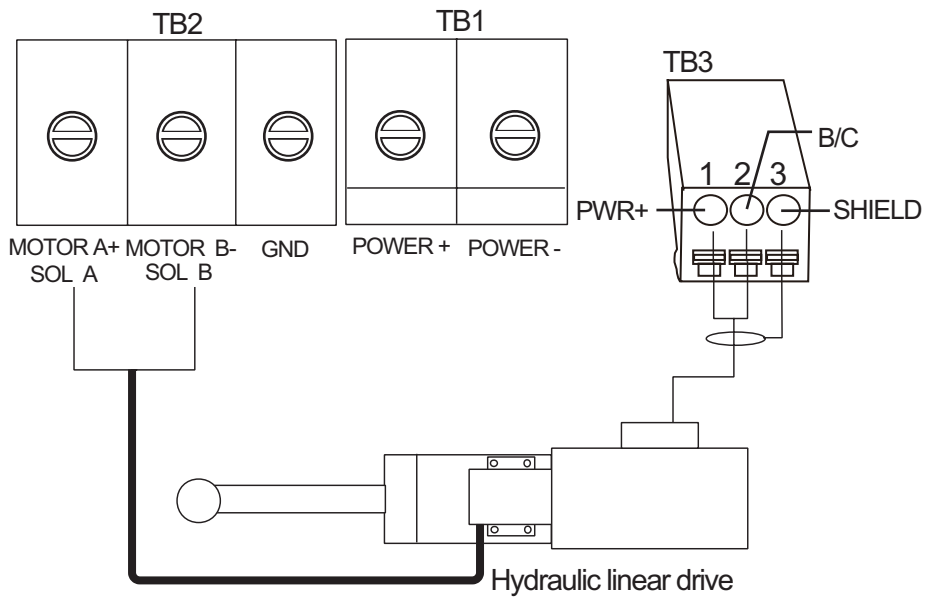



### How to connect the Accu-Steer FPS 12V/24V helm sensor

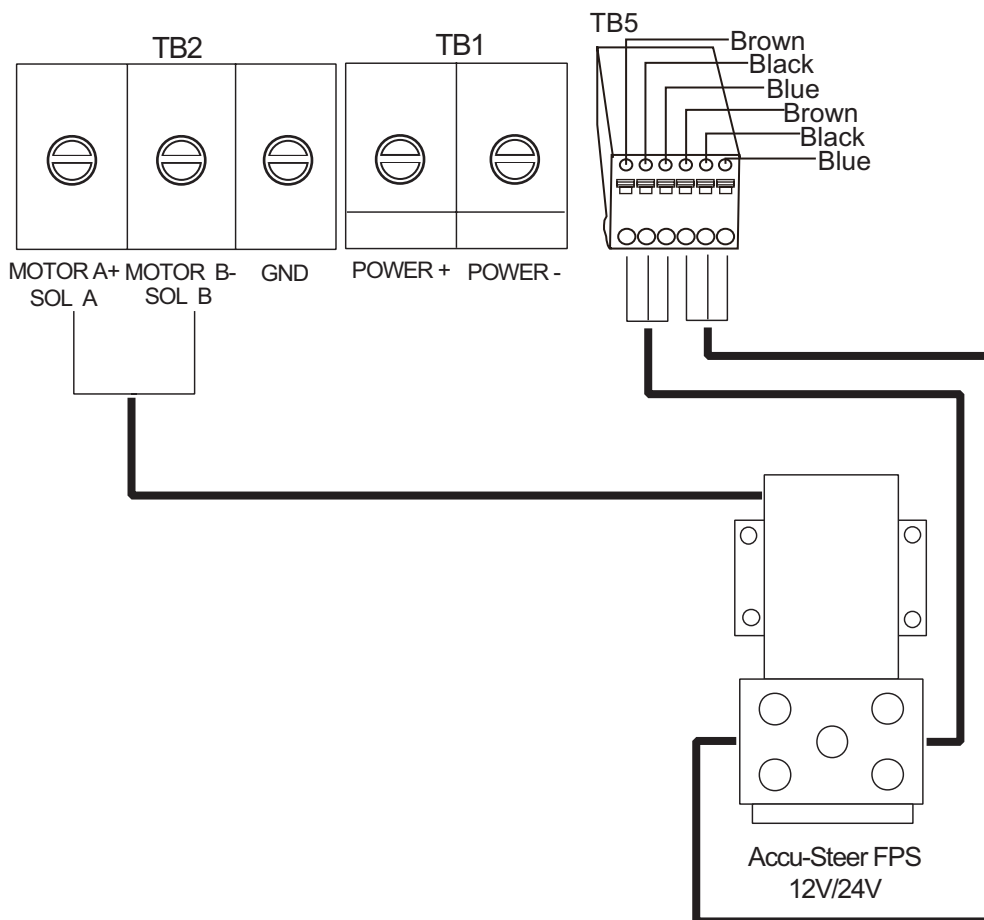

#### 2.2.6 Teleflex linear sensor

To connect a Teleflex linear sensor AR4502 (instead of the FAP-6112), do the following modification.

1. Make the cable connection as shown below. Refer to the installation manual of the linear sensor for recommended cable.

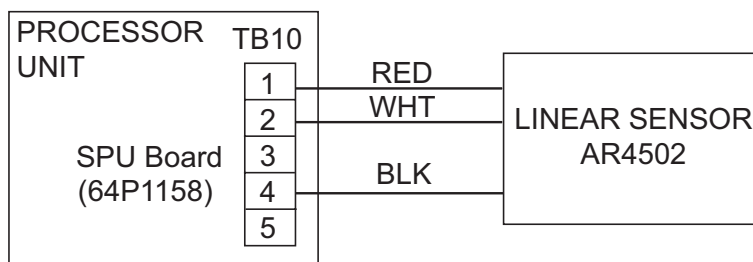

Wind tape where shield was removed.

2. Set the RRU type to [LINEAR SENSOR] on the [DOCKSIDE SETUP] menu when you do the initial settings, in the next chapter.

### **2.2.7 CAN bus power**

The maximum current that can be supplied to the CAN bus network is 1A. Use a “floating power supply” and make sure it meets with CAN bus (NMEA 2000) regulations.

For complete information about CAN bus wiring, see the “Furuno CAN bus Network Design Guide (TIE-00170-\*)” on Tech-Net.

### **2.2.8 Connection to TB4**

TB4 is for contact relay output. The No.1 line is Normal Open, and the No.3 line is Normal Close. For Active Close, use Normal Open; for Active Open use Normal Close. The rated current of the contact is 3A. The maximum acceptable open-close is 50VA.

## **2.3 Control Unit**

**Note:** For how to connect the Control Unit FAP-7011C with the Processor Unit FAP-7002, see the operator’s manual (OME-72780).

### **FAP-7001/FAP-7011**

A maximum of six Control Units can be connected. The Processor Unit has two ports for connection of two main Control Units, and two Control Units can be connected in series to each main Control Unit.

Use the cable BD-07AFFM-LR-150 (supplied) to connect the Control Unit and Processor Unit, and use cable BD-07AF-07AF-LR-100 (optional supply) to connect two Control Units.

### **FAP-7021**

A maximum of two Control Units can be connected. Use the cable attached to the Control Unit (10 m) to connect the Control Unit to the Processor Unit. To increase the length, use the optional Cable Extension Kit.

### **Notes on connection of Control Units**

- Attach the terminator BD-07AFFM-LR7001 to the port not used on the last Control Unit in the series.
- To connect a single Control Unit, use TB8.
- The total length of cables in a series must be within 35 m.

- FAP-7021 can be connected at the end of FAP-7001/FAP-7011 Control Unit.

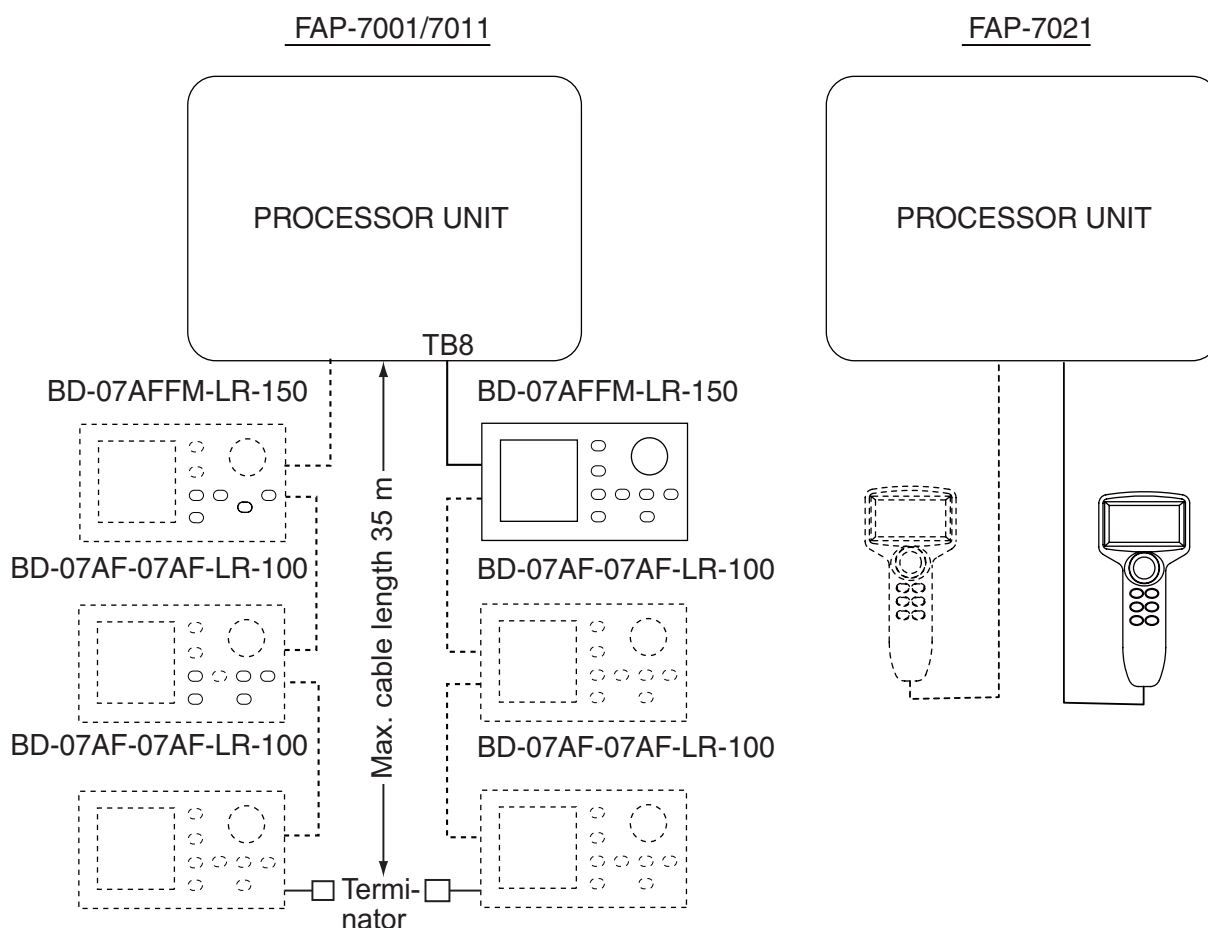

## 2.4 Remote Controllers (option)

The Processor Unit has two ports for connection of two remote controllers.

The Distributor FAP-6800 allows you to connect three NFU (Non Follow-Up) type remote controllers to the Processor Unit.

**Note 1:** Connect remote controllers that have connectors to the Distributor FAP-6800.

**Note 1:** The remote controllers are not available with Fantum Feedback™.

**Note 3:** Set the remote controller type on the [SYSTEM SETUP] menu, in chapter 3.

Remote controllers with connector	Remote controller without connector
FAP-5551 (dial), FAP-6211 (button), FAP-6221 (lever), FAP-6231 (dodge)	FAP-5552 (dial), FAP-6212 (button), FAP-6222 (lever), FAP-6232 (dodge)

### 2.4.1 Example remote controller connections

#### No distributor

Connect any two remote controllers.

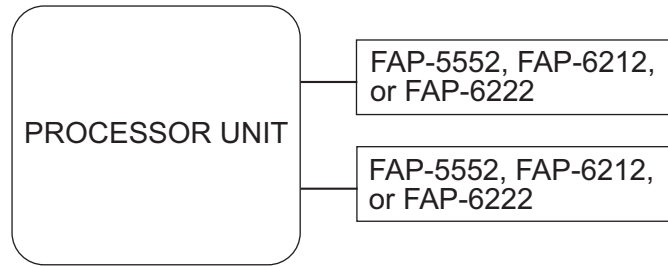

#### Dial-type remote controller

The distributor cannot be used with the dial-type remote controller.

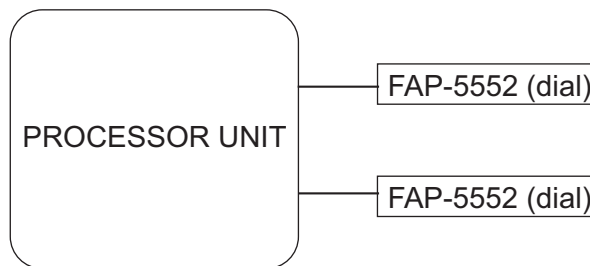

#### Button- or lever-type remote controller with distributor

Connect a maximum of six button- or lever-type remote controllers.

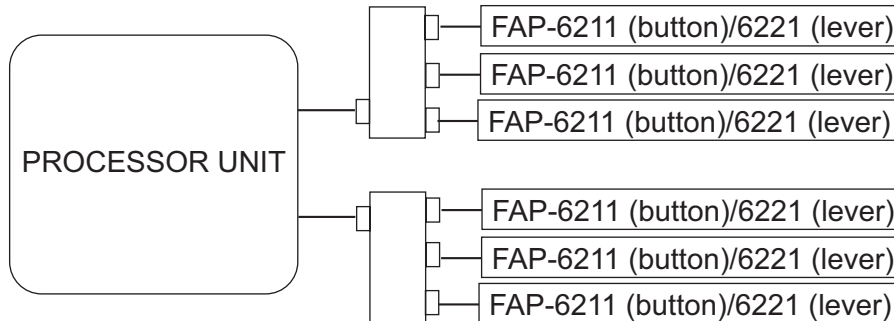

#### Dodge-type remote controller with distributor

Connect a maximum of six dodge-type remote controllers.

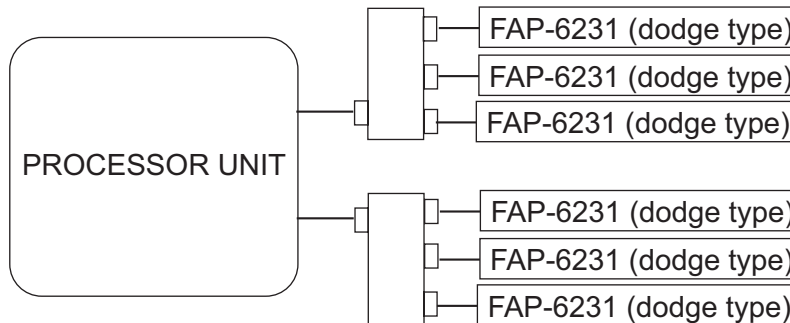

## 2.4.2 Prohibited remote controller connections

The remote controller combinations shown in this section are not allowed.

### Wrong connection no.1

You cannot connect different types of remote controllers.

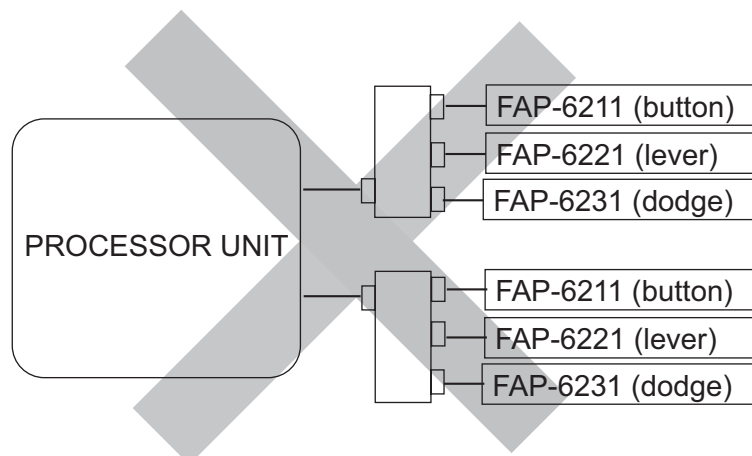

### Wrong connection no.2

Connect only one dial-type remote controller.

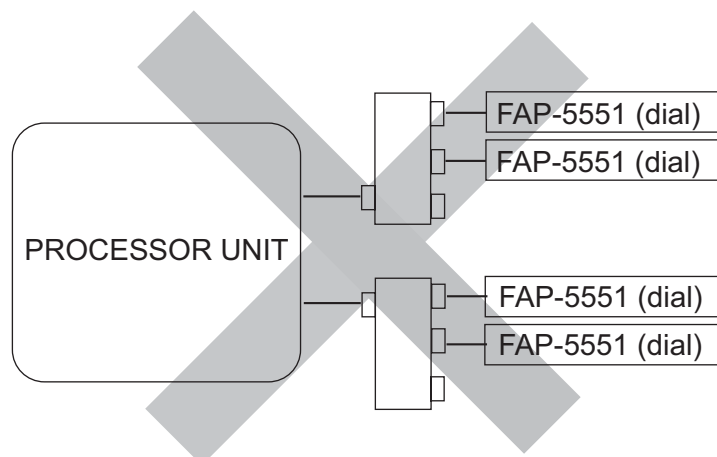

### Wrong connection no.3

You cannot connect multiple distributors.

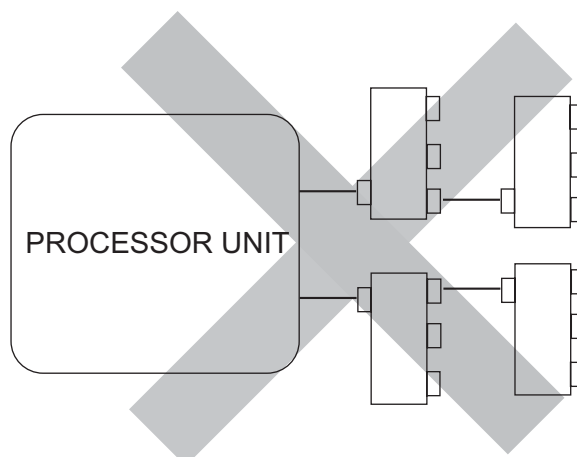

## 2.5 Input/Output Sentences

### NMEA0183 Port1, NMEA0183 Port 2, Input

Data	Sentences(Priority)	Remarks
Heading(True)	THS>HDT>(Heading(Mag)+Mag Var.)	NMEA0183 Ver.1.5/2.0/ 3.0 200ms inter- val
Heading(Mag)	HDG>HDM>(Heading(True)-Mag Var.)	200ms inter- val
Mag variation	HDG>RMC	
Position	GNS>GGA>GLL>RMC	
Speed	(STW)(VHW)>(SOG)(VTG>RMC)	
Waypoint Information (Waypoint location) (XTE) (Waypoint arrival alarm) (Bearing and distance to waypoint)	APB>RMB>(BWR+XTE+AAM)>(BWC+ XTE+AAM)>(BOD+XTE+AAM)  <b>Note:</b> The following conditions apply: <b>APB or RMB selected:</b> AAM's "Arrival circle radius". <b>APB or (BOD+XTE+AAM) selected:</b> RMB's "Waypoint location". <b>APB or (BOD+XTE+AAM) selected:</b> RMB>BWR>BWC's "Distance".	
Course	RMC>VTG	
Depth	DPT>DBT	
Water temperature	MTW	
Time and Date	ZDA>RMC	
Wind speed, direction(True)	MWV>VWT	
Wind speed, direction(Apparent)	MWV>VWR	
Rate of Turn	ROT	
Target L/L	TLL	

### NMEA0183 Port1, NMEA0183 Port 2, Output

Data	Sentences(Priority)	Remarks
Heading(True)	HDT	
Heading(Mag)	HDG, HDM	
Mag variation	HDG, RMC	
Position	GNS, GGA, GLL, RMC	
Speed	VHW, VTG, RMC	
Course	RMC, VTG	
Depth	DPT, DBT	
Water temperature	MTW	
Time and Date	ZDA, RMC	
Wind speed, direction(True)	MWV, VWT	
Wind speed, direction(Apparent)	MWV, VWR	
Rate of Turn	ROT	
Rudder	RSA	Not output in case of Fantum Feedback™.

**CAN bus Port. Input**

PGN Title	PGN
Actual Pressure	130314
Additional Weather Data	130880
COG & SOG, Rapid Update	129026
Cross Track Error	129283
Direction Data	130577
Direction Data	130577
Engine Parameters, Dynamic	127489
Engine Parameters, Rapid Update	127488
Environmental Parameters (Temperature (Sea, Ambient), Atmospheric Pressure)	130310
Environmental Parameters (Temperature (Sea, Ambient))	130312
Environmental Parameters (Temperature (Sea, Ambient), Humidity, Atmospheric Pressure)	130311
GNSS Position Data	129029
Humidity	130313
ISO Acknowledgement	059392
ISO Address Claim	060928
ISO Request	059904
Magnetic Variation	127258
Memory Clear Group Function	126720
Navigation - Route/WP Information	129285
Navigation Data	129284
NMEA - Request Group Function	126208
PGN List - Transmit PGN's Group Function	126464
Position, Rapid Update	129025
Product Information	126996
Rate of Turn	127251
Self Test Group Function	061184
Speed, Water Referenced	128259
System Time	126992
Time and Date	129033
Vessel Heading	127250
Water Depth	128267
Wind Data	130306

**CAN bus Port, Output**

PGN Title	PGN
Browser Control Status	130823
COG & SOG, Rapid Update	129026
Cross Track Error	129283
Environmental Parameters (Temperature (Sea, Ambient), Atmospheric Pressure)	130310
Environmental Parameters (Temperature (Sea, Ambient))	130312
Environmental Parameters (Temperature (Sea, Ambient), Humidity, Atmospheric Pressure)	130311
GNSS Position Data	129029
Heading/Track Control	127237
ISO Acknowledgement	059392
ISO Address Claim	060928
ISO Request	059904
Magnetic Variation	127258
Memory Clear Group Function	126720
Navigation - Route/WP Information	129285
Navigation Data	129284
NMEA - Request Group Function	126208
PGN List - Transmit PGN's Group Function	126464
Position, Rapid Update	129025
Product Information	126996
Rate of Turn	127251
Rudder	127245*
Self Test Group Function	061184
Speed, Water Referenced	128259
System Time	126992
Time & Date	129033
Unit Division Code	130822
Vessel Heading	127250
Water Depth	128267
Wind Data	130306

\*: Not output in case of Fantum Feedback™.



# 3. INITIAL SETTINGS

**Note:** For initial settings of the NAVpilot-711C, see the operator’s manual (OME-72780).

## 3.1 About Initial Settings, Menu Operation

This chapter shows you how to enter initial settings, on the [INSTALLATION] menu. The menu contains some items that may not apply to your system. To return to the [INSTALLATION] menu, push the **MENU** key.

Minimally, the settings on the following menu must be done:

- [SHIP’S CHARACTERISTICS] menu
- [DOCKSIDE SETUP] menu

**Note:** The [DOCKSIDE SETUP] menu is not shown when [BOAT TYPE] is set to [VOLVO EVC BOAT].

All operations on the menu are done with the **Course control** knob and **MENU** key

Control, key	Usage
<b>Course control</b> knob	Rotate the knob to select a menu item then push the knob. Rotate the knob to select setting or enter alphanumeric value then push the knob to confirm setting. This manual refers to the <b>Course control</b> knob as “knob”.
<b>MENU</b> key	Go to previous screen.



## 3.2 How to Select Language and Units, Open the Installation Menu

1. Press the **POWER/BRILL** key (NAVpilot-700) or the **POWER/STBY** key (NAVpilot-711/720) to turn on the power. The splash screen appears followed by the startup test and the language selection menu, shown below. The default language is English(USA). If you don't need to change the language, push the knob and go to step 2. To change the language, rotate the knob to select a language then push the knob.

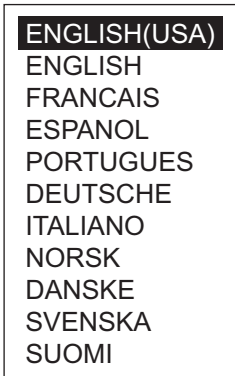

2. Press the **▶** key to show the [UNIT SETUP] menu.

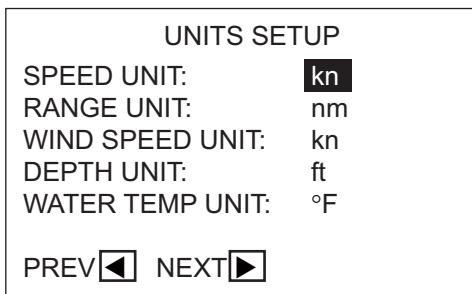

3. The units on the [UNIT SETUP] menu are set according to the language selected. If you require different units, change them as follows.
  - 1) Rotate the knob to select the setting to change then push the knob.
  - 2) Rotate the knob to select a unit then push the knob.
4. Press the **▶** key to show the [OPERATION MODE] menu.

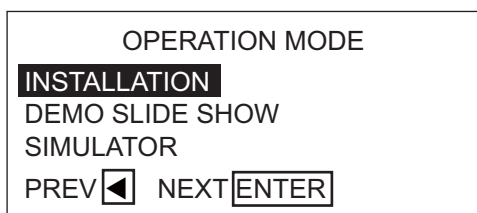

5. [INSTALLATION] is selected. Push the knob to show the [INSTALLATION] menu.

<i>Page 1</i>	<i>Page 2</i>
INSTALLATION MENU	INSTALLATION MENU
LANGUAGE: ENGLISH	DATA CALIBRATION
UNITS SETUP	PARAMETER SETUP
DISPLAY SETUP	AUTO OPTION
SHIP'S CHARACTERISTICS	NAV OPTION
DOCKSIDE SETUP	FISH HUNTER OPTION*3
CAN BUS SETUP	SYSTEM SETUP
NMEA0183 SETUP	RC SETUP*3
SENSOR SELECTION	ALARM
UNIVERSAL PORT	
SEA TRIAL	
RUDDER LIMIT SETUP: NO*1,*3	
RUDDER TEST: NO*1	
SET CENTER RUDDER POS.: NO*1,*3	
COMPASS CALIBRATION: NO*1, *2	

\*1 : NO is replaced with DONE when respective setup is successfully completed.

\*2 : Shown if PG-500 or PG-700 is connected.

(NAVpilot-700 installation menu shown.)

**Note1:** The [INSTALLATION] menu changes according to the system configuration.

**Note2:** The [INSTALLATION] menu can be opened from the STBY display by pressing the knob three times while pressing and holding down the **MENU** key.

6. Follow the procedures in the remaining sections (in the order shown) of this chapter to set up the NAVpilot.

### 3.3 Display Setup

The [DISPLAY SETUP] menu lets you set display indications according to your needs, like how to show the date and time.

DISPLAY SETUP  
 HEADING FORMAT: **HHH°**  
 XTE FORMAT: \* \*\*  
 POSITION FORMAT:  
                   DD°MM.MM'  
 HEADING DISPLAY: TRUE  
 DATE DISPLAY: MM DD, YYYY  
 TIME DISPLAY: 24HOUR  
 DATA BOX FORMAT: 2BOXES  
 TEMP GRAPH: 5min

*Items of the DISPLAY SETUP menu*

Item, description	Settings	Item, description	Settings
[HEADING FORMAT] Select how to show the heading indication, in three or four figures.	HHH° HHH.H°	[DATE DISPLAY] Select how to show the date.	MMM DD, YYYY DD MMM YYYY YYYY MM DD
[XTE FORMAT] Select how to show the XTE indication, in three or four figures.	* ** * . ** * *** * .	[TIME DISPLAY] Select how to show the time.	12HOUR 24HOUR
[POSITION FORMAT] Select how to show the position indication, in degrees, minutes, seconds.	DD°MM.MM' DD°MM.MMM' DD°MM.MMMM' DD°MM.SS.S"	[DATA BOX FORMAT] Select how many data boxes to show on the nav data display. (Requires appropriate sensors.)	2BOXES 3BOXES NAVpilot-700  1BOX 2BOXES NAVpilot-711 NAVpilot-720
[HEADING DISPLAY] Select how to show heading, true or magnetic.	MAGNETIC TRUE	[TEMP GRAPH] Select the time scale for the water temperature graph. (Requires water temperature sensor.)	5min 10min 20min

## 3.4 Ship's Characteristics Menu

The [SHIP'S CHARACTERISTICS] menu sets up the NAVpilot according to boat type, length, cruising speed and rate of turn.

SHIP'S CHARACTERISTICS BOAT TYPE: <b>SEMI-DISPLACE</b> RUDDER SENSOR*: INSTALLED BOAT LENGTH: 40ft(12.2m) CRUISING SPD: 30kn RATE OF TURN: 5°/s
--

\*: When the [BOAT TYPE] is set to [PLANING] or [SEMI-DISPLACE], [RUDDER SENSOR] is displayed.

1. The cursor is selecting the setting for [BOAT TYPE]; push the knob.

PLANING <b>SEMI-DISPLACE</b> DISPLACEMENT SAILBOAT VOLVO EVC BOAT
---

2. Rotate the knob to select your boat type then push the knob.

[PLANING]: Jet boats, fast patrol boats, sport fishing boats

[SEMI-DISPLACE]: Pilot boats, power boats, fast catamaran boats

[DISPLACEMENT]: Pedal boats, fishing boats, work boats, houseboats

[SAILBOAT]: Sailboats

[VOLVO EVC BOAT]: VOLVO IPS drive equipped boats

When the [BOAT TYPE] is set to [PLANING] or [SEMI-PLANING], [RUDDER SENSOR] is displayed. Refer to step 3 to select [INSTALLED] or [FANTUM FEEDBACK].

[INSTALLED]: When the rudder reference unit is installed

[FANTUM FEEDBACK]: When the rudder reference unit is not installed

**Note1:** When [FANTUM FEEDBACK] is selected, the options of the [BOAT TYPE] are [PLANING] or [SEMI-DISPLACE].

**Note2:** If [BOAT TYPE] is changed after completion of the installation settings, reenter initial settings to reflect change in boat type.

3. Set [RUDDER SENSOR], [BOAT LENGTH], [CRUISING SPD], and [RATE OF TURN] as follows:

- 1) Rotate the knob to select the current value of an item then push the knob.

- 2) Rotate the knob to set a value then push the knob.

**Note:** Set the rate of turn according to your boat's specifications. If the rate is set higher than your boat's specifications, the rudder may turn abruptly when arriving at a waypoint, creating a dangerous situation. Further, it may not be possible to change course correctly if the rate is higher than the actual rate of turn of your boat.

## 3.5 Dockside Setup Menu

The dockside setup menu for RRU and Fantum Feedback™ is different.

### 3.5.1 Dockside setup for RRU

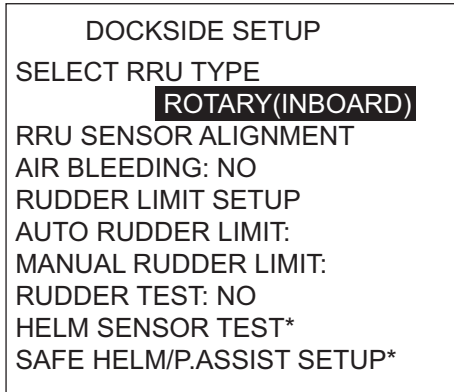

\* Displayed if Accu-Steer drive unit is selected.

#### RRU type

1. The cursor is selecting [SELECT RRU TYPE]; push the knob.

2. Rotate the knob to select correct option then push the knob.



[ROTARY(INBOARD)]: For FURUNO Rudder Reference Unit FAP-6112.

[LINEAR(OUTBOARD)]: For Teleflex linear sensor AR4502.

#### RRU sensor alignment

3. Go back to the [DOCKSIDE SETUP] menu.

4. Rotate the knob to select [RRU SENSOR ALIGNMENT] then push the knob.

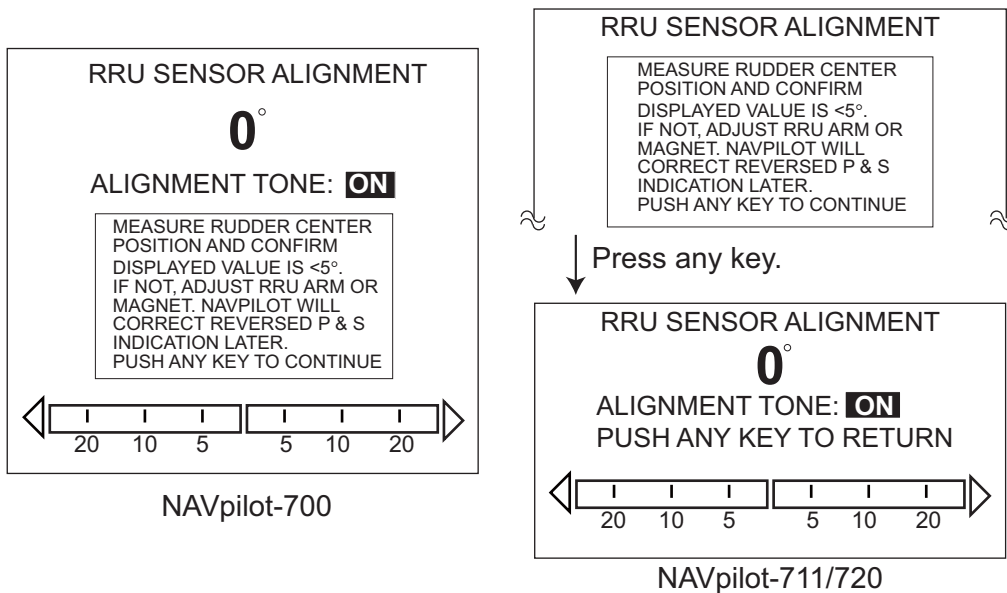

5. With the rudder physically centered, confirm that the displayed rudder angle indication is less than or equal to  $\pm 5^\circ$ . If not, you must adjust the rudder sensor body or magnet position (for Teleflex linear sensor AR4502) so that the indicator is within  $\pm 5^\circ$  before continuing.

**Alignment Tone:** There is an alignment tone that you can use to help you make this adjustment remotely. A beep sounds continuously when the indicator is within  $\pm 5^\circ$ . If you do not need the alignment tone, you may turn it off by pushing the knob and selecting [OFF] with [ALIGNMENT TONE].

### **Air bleeding**

6. Go back to the [DOCKSIDE SETUP] menu. Select [AIR BLEEDING] and push the knob.



7. The cursor is selecting [NO]; push the knob. Rotate the knob to select [YES] then push the knob to show the following display.

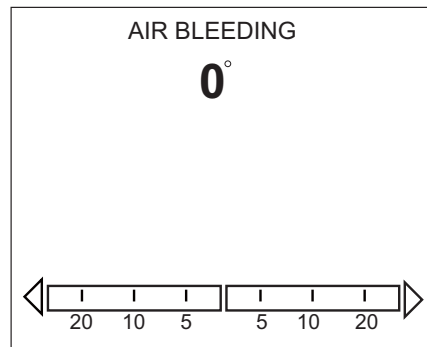

8. The display shows “DETECTING DRIVE UNIT” while searching your drive unit. If your drive unit is “REVERSIBLE,” the display shows [REVERSIBLE 12V], [REVERSIBLE 24V], [SAFE HELM 12V], or [SAFE HELM 24V]. If your drive unit is “SOLENOID”, nothing appears on the display.

**Note:** If the drive type could not be detected, the left-hand screen shown below appears. [UNKNOWN] is selected; push the knob to display the popup. Select your drive type.

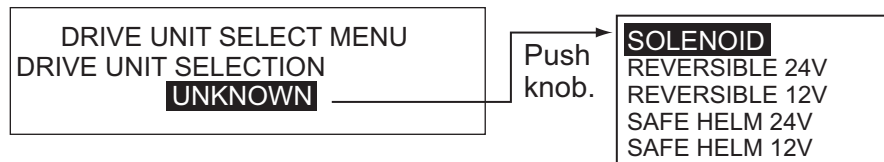

9. The following popup message appears.

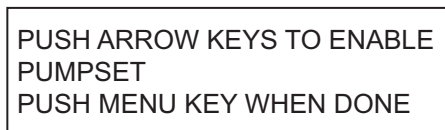

**Note:** If you have the Accu-Steer helm sensor, the message “A HELM SENSOR IS INSTALLED. SAFE HELM AND POWER ASSIST IS AVAILABLE. PUSH ENTER TO CONTINUE.” appears before the above popup message. Push the knob to show the above message.

### 3. INITIAL SETTINGS

10. Press the ◀ (or ▶) key until the indicator is completely filled (in black).
11. Remove the appropriate rubber cap of the cylinder to bleed air.
12. Press the ◀ (or ▶) key until the indicator is completely filled (in black).
13. Remove the appropriate rubber cap of the cylinder to bleed air.
14. Repeat steps 10-13 to bleed air completely.

#### **Rudder limit setup**

15. Go back to the [DOCKSIDE SETUP] menu. Select [RUDDER LIMIT SPEED] and push the knob.

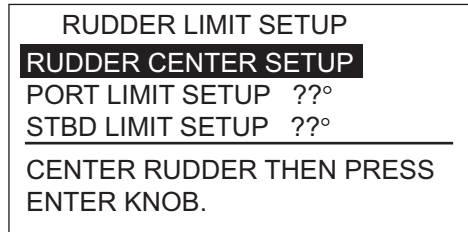

Set the rudder center position, then set the maximum rudder limits or "hard-over" points for the rudder system.

NAVpilot will AUTOMATICALLY set the port/starboard direction of the rudder angle in this step. It does not matter which way the rudder reference unit arm or linear sensor rod is installed as this correction will be done electronically.

NAVpilot will AUTOMATICALLY "linearize" the rudder indication values if the rudder turns further in one direction than the other direction. Therefore, it is recommended that you make both port and starboard rudder values the same. This will avoid confusion for the customer during operation. Also, numeric value selected is not critical and need not be measured as long as you feel that your estimation is close to the proper value.

16. The cursor is selecting [RUDDER CENTER SETUP]; push the knob.

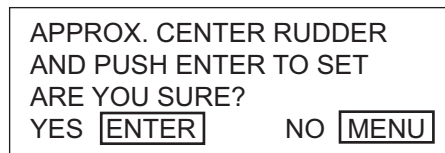

17. Turn the helm so rudder is centered then push the knob. The [RUDDER LIMIT SETUP] menu appears.
18. Rotate the knob to select [PORT LIMIT SETUP].
19. Turn the helm hard-over to port then enter port rudder limit.
20. Rotate the knob to select [STBD LIMIT SETUP].
21. Turn helm hard-over to starboard then enter starboard rudder limit.

**Note 1:** If the angle is wrong at step 16, 19 or 21 an error message appears. In this case go back to the [RRU SENSOR ALIGNMENT] menu and check if the RRU setting is correct.



**Note 2:** If the setup failed, one of the following messages appears. Re-do the rudder limit setup. If the message appears again, re-adjust the RRU. See page 1-7 for the rotary sensor. For the linear sensor, see its manual.

- RRU CENTER(PORT or STBD) POS IS OUT OF RANGE-TURN HELM OR ADJUST RRU THEN TRY AGAIN
- BELOW STEPS NOT COMPLETE RUDDER CENTER(,PORT LIMIT or STBD LIMIT) RETRY?
- RRU SETUP ERROR-MUST TURN HELM HARD OVER PORT/STBD RETRY?

### **Auto rudder limit**

Auto rudder limit determines the maximum rudder movement in degrees from the mid position in the Auto, Nav, Turn, FishHunter™, Dodge and Wind modes. The value set here should not be greater than the limit set for Rudder Limit.

22. Go back to the [DOCKSIDE SETUP] menu, select [AUTO RUDDER LIMIT:] then push the knob. The current value is circumscribed with a double rectangle.

23. Rotate the knob to set the rudder limit desired then push the knob. (Setting range: 10° to max. rudder limit)

### **Manual rudder limit**

In the Remote (FU and NU), FU Dodge or NFU Dodge modes, usually a wide range of rudder angles are used, and therefore a larger number should be entered. However, the setting must not exceed the rudder limit angle which is inherent on your boat.

Do not set the limit higher than the rudder limit. It is recommended to set the manual rudder limit equal to or greater than the auto rudder limit. If the manual rudder limit is set lower than the auto one, the rudder may be returned to center position too quickly when the vessel is doing automatic turning by operation from the remote controller or DODGE key.

24. Go back to the [DOCKSIDE SETUP] menu and select [MANUAL RUDDER LIMIT:] then push the knob. The current value is circumscribed with a double rectangle.

25. Rotate the knob to set the rudder limit desired then push the knob. (Setting range: 10° to max. rudder limit)

### 3. INITIAL SETTINGS

#### **Rudder test**

For power steering vessels with an engine driven power steering pump, the engines must be running and slightly above idle before this test is done. BEFORE doing this test, check that [RUDDER DEADBAND] in the [SEA TRIAL] menu is set to [AUTO].

26. Go back to the [DOCKSIDE SETUP] menu, select [RUDDER TEST] then push the knob. The cursor is selecting [NO]; push the knob. Select [YES] then push the knob to start the test.

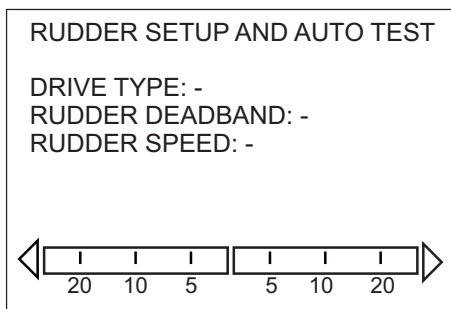

The rudder test automatically detects drive unit type as follows:

#### **Successful detection**

SOLENOID: The test automatically continues.

REVERSIBLE: The following menu appears. Select correct drive unit type with the **Course control** knob and push the knob. Then, the test continues.

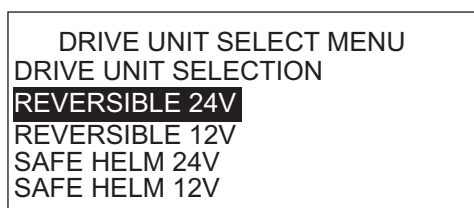

**Note:** IN PORT1 and INPORT2 are disabled when SAFE HELM is selected.

#### **Failed detection**

“RUDDER TEST FAILED” appears. The rudder test is discontinued.

The results are shown on the screen as follows:

[DRIVE TYPE]: [REVERSIBLE12V](or 24V), [SAFE HELM 12V](or 24V), or [SOLENOID]

[RUDDER DEADBAND]: [OK] or [BIG]

[RUDDER SPEED]: [OK], [SLOW], or [FAST]

27. Press the [MENU] key to return to the [DOCKSIDE SETUP] menu.

28. Set the deadband of the rudder, automatically or manually. The setting is normally performed automatically during the RUDDER TEST. Manually setting the parameter is normally not recommended and may in fact be only useful on older vessels with chain driven or old worn rudder system. If it is necessary to set it manually, do the following:

- 1) Select [RUDDER DEADBAND] on the [SEA TRIAL] menu then push the knob.
- 2) Select [MANUAL] then push the knob.
- 3) Rotate the knob to select the value shown then push the knob.
- 4) Rotate the knob to set the value shown then push the knob.

When the following messages appear, rudder test is completed successfully.

- RUDDER TEST COMPLETED.
- RUDDER SPEED IS TOO FAST TO CONTROL THE VESSEL. THE VESSEL MAY NOT BE CONTROLLED PROPERLY.
- RUDDER SPEED IS TOO SLOW TO CONTROL THE VESSEL. THE VESSEL MAY NOT BE CONTROLLED PROPERLY.

**Note 1:** If rudder deadband is higher than  $1.3^\circ$ , the boat cannot be controlled correctly. Check for air in the steering system and if the rudder speed is greater than  $10^\circ/s$ .

**Note 2:** If you set the deadband manually, do not set the value too low. Hunting can result.

**Note 3:** if the rudder test could not be completed successfully one of the following messages appear. Do the test again after resolving the problem.

- RUDDER TEST FAILED.
- DEADBAND IS TOO BIG TO CONTROL THE VESSEL. THE VESSEL MAY NOT BE CONTROLLED PROPERLY. PLEASE SEE INST MANUAL FOR MANUAL DB SETTING.
- RUDDER ANGLE ERROR CHECK DRIVE CIRCUIT
- RUDDER DRIVE ERROR

### 3.5.2 Dockside setup for Fantum Feedback™

DOCKSIDE SETUP

DRIVE UNIT SELECTION: UNKNOWN

AIR BLEEDING: NO

RUDDER TEST: NO

HELM SENSOR TEST\*

SAFE HELM/P.ASSIST SETUP\*

\* Displayed if Accu-Steer drive unit is selected.

#### How to set the drive unit

1. Use the knob to select [DRIVE UNIT SELECTION] then push the knob.
2. Rotate the knob to select [REVERSIVLE 24V], [REVERSIBLE 12V], [SAFE HELM 24V], or [SAFE HELM 12V] then push the knob.

#### Air bleeding

**Note:** Air bleeding can not be performed if the drive unit has not been selected.

1. Go back to the [DOCKSIDE SETUP] menu.
2. Rotate the knob to select [AIR BLEEDING] then push the knob.

AIR BLEEDING

AIR BLEEDING: NO

### 3. INITIAL SETTINGS

3. The cursor is selecting [NO]; push the knob. Rotate the knob to select [YES] then push the knob to show the following message.

AIR BLEEDING

PUSH ARROW KEYS TO ENABLE  
PUMPSET  
PUSH MENU KEY WHEN DONE

4. Press the ◀ (or ▶) key.
5. Remove the appropriate rubber cap of the cylinder to bleed air.
6. Press the ◀ (or ▶) key.
7. Remove the appropriate rubber cap of the cylinder to bleed air.
8. Repeat steps 4-7 to bleed air completely.

#### **Rudder test**

**Note:** The rudder test can not be performed if the drive unit has not been selected.

1. Go back to the [DOCKSIDE SETUP] menu.
2. Rotate the knob to select [RUDDER TEST] then push the knob.
3. The cursor is selecting [NO]; push the knob. Rotate the knob to select [YES] then push the knob to show the following message.

USE WHEEL TO  
CENTER RUDDER BEFORE  
RUDDER TEST.  
ARE YOU SURE?  
YES [ENTER] NO [MENU]

4. Center the rudder then push the knob.
5. Confirm the direction that the rudder move with pressing the ▶ key.
6. Release the ▶ key.
7. Press the ◀ (or ▶) key according to the direction that confirmed at step 5.
8. Turn the helm or press the ◀ (or ▶) key hard-over to PORT/STBD then push the knob.
9. Long press the ◀ (or ▶) key hard-over to the opposite direction from step 8.
10. When the rudder is reached to hard limit, release the ◀ (or ▶) key to display following message.

HAS THE RUDDER REACHED  
THE HARD LIMIT?

YES [ENTER] NO [MENU]

Long-press the ◀ (or ▶) key to turn hard-over in direction opposite that done in step 8 then select [YES]. If not, select [NO] and go back to step 8.

11. At the completion of the rudder test, one of the results shown below appears.
  - RUDDER TEST COMPLETED.

- RUDDER SPEED IS TOO FAST TO CONTROL THE VESSEL. THE VESSEL MAY NOT BE CONTROLLED PROPERLY.
- RUDDER SPEED IS TOO SLOW TO CONTROL THE VESSEL. THE VESSEL MAY NOT BE CONTROLLED PROPERLY.

If the steering speed needs to be adjusted the following message appears. To adjust the steering speed, press the knob and go to step 8. If adjustment is not required, press the MENU key to escape.

RUDDER SPEED IS NOT APPROPRIATE. RETRY TEST AND ADJUST RUDDER SPEED?

ADJUST

ABORT

12. Press the any key to finish the rudder test.

### 3.5.3 How to set the safe helm mode and power assist mode

#### Helm sensor test (for Accu-Steer FPS 12V (or 24V) drive)

The helm sensor test checks the connection between the processor unit and the Accu-Steer FPS 12V (or 24V) drive. If your drive unit is different, go to section 3.6.

1. Select [HELM SENSOR TEST] in the [DOCKSIDE SETUP] menu then push the knob.

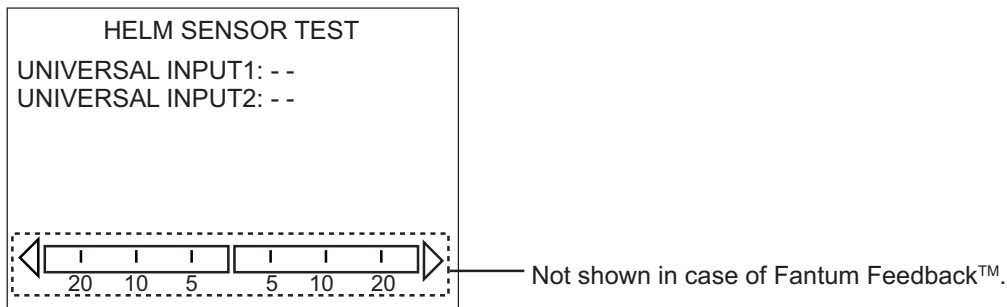

2. Select [YES] to start the helm sensor test.

USE WHEEL TO CENTER RUDDER BEFORE HELM SENSOR TEST. ARE YOU SURE?

RUDDER AT CENTER

CANCEL

3. Center the rudder then push the knob to show the pop-up message.

TURN HELM PORT OR STBD. PUSH ANY KEY TO ABORT.

When the RRU is installed

TURN HELM TO MOVE RUDDER FOR STBD SIDE. PUSH ANY KEY TO ABORT.

For Fantum Feedback™

4. **When the RRU is installed:** Turn the helm to PORT or STBD direction.

**For Fantum Feedback™:** Turn the helm to STBD direction.

5. **When the RRU is installed:** Turn the helm to the opposite direction from step 4.

**For Fantum Feedback™:** Turn the helm to PORT direction.

If the connection is normal, the message "HELM SENSOR TEST COMPLETED." appears. For failure, "HELM SENSOR TEST FAILED." appears. Check that your helm

### 3. INITIAL SETTINGS

sensor is Accu-Drive FPS 12V/24V. Also, check that the helm sensor is correctly connected to TB5.

6. Push the knob to show the result of the helm sensor test.

HELM SENSOR TEST  
UNIVERSAL INPUT1: STBD\*  
UNIVERSAL INPUT2: PORT\*  
  
PUSH ANY KEY TO CONTINUE

\*: "--" is shown when the helm sensor test is failed.

### **Safe helm/p.assist setup (for Accu-Steer FPS 12V (or 24V) drive)**

The safe helm and power assist features are available with the Accu-Steer FPS 12V (or 24V) drive unit.

The safe helm mode temporarily switches the NAVpilot to manual steering for the specified time interval when the helm is steered in an automatic steering mode (AUTO, NAV, etc.). This prevents continued turning of the helm. The mode and course indications flash when the safe helm mode activates.

The safe helm mode is deactivated and the previous automatic steering mode is restored in conditions mentioned below.

**NAV mode:** When the data from the helm sensor is not input for the set time on [RETURN DELAY]\*.

**AUTO, WIND mode, etc. (except NAV mode):** When cruising straight ahead and the data from the helm sensor is not input for the set time on [RETURN DELAY]\*.

\*: See "How to set the safe helm mode" to set [RETURN DELAY].

The power assist mode customizes manual steering to your own preferences. The mode is available during the safe helm mode and the STBY mode. The indication "PA" appears at top of the screen when the mode is active.

The safe helm/p.assist menu appears after the helm sensor test is successfully completed.

### **How to set the safe helm mode**

SAFE HELM/P.ASSIST SETUP  
SAFE HELM: **ON**  
RETURN DELAY 5 SEC  
SAFE HELM RESPONSE  
SAFE HELM BEEP: ON  
POWER ASSIST: OFF

1. Use the knob to select [SAFE HELM] in the [DOCKSIDE SETUP] menu then push the knob.
2. Use the knob to select [ON] then push the knob to activate safe helm.
3. Use the knob to select [RETURN DELAY] then push the knob.

4. Rotate the knob to set the return delay.

The setting range is 1-20 seconds.

**NAV mode:** When the data from the helm sensor is not input for the set time, NAV mode is restored.

**AUTO, WIND mode, etc. (except NAV mode):** When cruising straight ahead and the data from the helm sensor is not input for the set time, the previous steering mode is restored.

5. Use the knob to select [SAFE HELM RESPONSE] then push the knob.

SAFE HELM RESPONSE RESPONSE: <b>6</b> PORT STBD
TURN HELM PORT/STBD TO SET SAFE HELM RESPONSE TIME. HIGHER VALUE = FASTER RESPONSE  PUSH MENU KEY TO CONTINUE

6. Turn the knob to set the response then push the knob. The higher the value the faster the response. Turn the helm to port or starboard. A beep sounds and the indication PORT or STBD on the menu appears in reverse video.
7. Press the **MENU** key to close the window.
8. Use the knob to select [SAFE HELM BEEP] then push the knob.  
[SAFE HELM BEEP] turns the beep on of off when the safe helm mode is activated.
9. Use the knob to select [ON] or [OFF] then push the knob.
10. Press the **MENU** key to close the menu.

### How to set the power assist mode

SAFE HELM/P.ASSIST SETUP SAFE HELM: ON RETURN DELAY 5 SEC SAFE HELM RESPONSE SAFE HELM BEEP: ON POWER ASSIST: <b>OFF</b>
---

1. Use the knob to select [POWER ASSIST] in the [DOCKSIDE SETUP] menu then push the knob.
2. Use the knob to select [ON] then push the knob. When this is done the menu items for power assist appear.

SAFE HELM/P.ASSIST SETUP SAFE HELM: <b>ON</b> RETURN DELAY 5 SEC SAFE HELM RESPONSE SAFE HELM BEEP: ON POWER ASSIST: ON FOR SPEEDS UNDER 3.0kn POWER ASSIST STBY: ON POWER ASSIST RUDDER SPEED
--

3. Use the knob to select [FOR SPEEDS UNDER] then push the knob.

### 3. INITIAL SETTINGS

4. Rotate the knob to set the highest speed at which power assist activates. The setting range is 1.0 to 9.9 knots.
5. **If you want power assist in the STBY mode**, use the knob to set [POWER ASSIST STBY] to [ON].
6. Use the knob to select [POWER ASSIST RUDDER SPEED] then push the knob.

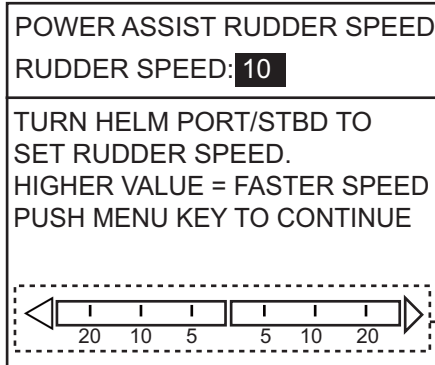

Not shown in case of Fantum Feedback™.

7. Turn the helm to port and starboard to set [POWER ASSIST RUDDER SPEED], and then push the knob. The setting range is 1 to 10 (default setting: 10). The higher the setting, the stronger the power assist.

#### 3.5.4 Confirmation of the dockside setup

After entering the dockside setup, confirm that the dockside setup is completed correctly, and the safe helm and power assist features work properly.

##### When the RRU is installed

- Confirmation of the rudder limit setup
  - 1) Show the rudder angle indicator.
  - 2) Turn the helm hard-over to port at the dockside.
  - 3) Confirm that the rudder angle indicator shows the value set at [RUDDER LIMIT SETUP].
  - 4) Turn the helm hard-over to starboard at the dockside.
  - 5) Confirm that the rudder angle indicator shows the value set at [RUDDER LIMIT SETUP].
- Confirmation of the AUTO mode at the dockside
  - 1) Show the rudder angle indicator.
  - 2) Select the AUTO mode at the dockside.
  - 3) Rotate the knob clockwise to set course.
  - 4) Confirm that the rudder turns to starboard with the rudder angle indicator.
  - 5) Rotate the knob counterclockwise to set course.
  - 6) Confirm that the rudder turns to port with the rudder angle indicator.



- Confirmation of the AUTO mode at sea.
  - 1) Select the safe area and cruise at low speed.
  - 2) Select the AUTO mode and confirm that NAVpilot controls the vessel properly.
- Helm sensor test
  - 1) Select [HELM SENSOR TEST] on the [DIAGNOSTIC] menu.
  - 2) Select [YES] to start the helm sensor test.
  - 3) Center the rudder then push the knob to show the pop-up message.
  - 4) Turn the helm to port or starboard, and then confirm that the steering direction at this step (“PORT“ or “STBD“) is shown at [UNIVERSAL INPUT1].
  - 5) Turn the helm to the opposite direction from step 4, and then confirm the steering direction at this step (“PORT“ or “STBD“) is shown at [UNIVERSAL INPUT2].

The example of the test result is shown as below.

HELM SENSOR TEST  
 UNIVERSAL INPUT1: STBD\*  
 UNIVERSAL INPUT2: PORT\*  
  
 PUSH ANY KEY TO CONTINUE

\*: “--” is shown when the helm sensor test is failed.

- Confirmation of the power assist feature
 

**Note:** When [POWER ASSIST] is set to [ON], do the following procedure.

  - 1) When [POWER ASSIST STBY] is set to [ON], select the STBY mode. When [POWER ASSIST STBY] is set to [OFF], select the AUTO mode.
  - 2) Turn the helm to port slowly, and then confirm that the rudder turns to port.
  - 3) Turn the helm to starboard slowly, and then confirm that the rudder turns to starboard.
- Confirmation of the safe helm feature
  - 1) Select the AUTO mode.
  - 2) Select the safe area and cruise at minimum speed.
  - 3) Turn the helm and adjust the response at [SAFEHELM RESPONSE].
  - 4) While turning the helm, confirm that the power assist feature does not work too strongly. If necessary, adjust the value at [POWER ASSIST REDDER SPEED].
  - 5) Center the rudder and stop steering. Then the steering mode is changed to the AUTO mode automatically. Adjust the return delay at [RETURN DELAY].
  - 6) Set the ship’s speed to the value set at [FOR SPEEDS UNDER].
  - 7) Turn the helm, and then confirm that the safe helm and power assist feature activate correctly.
 

**Note:** Do not turn the helm rapidly. If the power assist feature works strongly, the rudder can be turned more greatly than the turn as intended.
  - 8) Turn the helm and adjust the response at [SAFEHELM RESPONSE].
  - 9) When it is difficult to cruise at the speed set at step 6, adjust the setting value at [FOR SPEEDS UNDER] so that you can control the vessel easily.

### 3. INITIAL SETTINGS

#### **For Fantum Feedback™**

- Confirmation of the rudder steering
  - 1) Select the AUTO mode at the dockside.
  - 2) Rotate the knob clockwise to set the course.
  - 3) Confirm visually that the rudder turns to starboard.
  - 4) Rotate the knob counterclockwise to set the course.
  - 5) Confirm visually that the rudder turns to port.
- Confirmation of the AUTO mode at sea.
  - 1) Select the safe area and cruise at low speed.
  - 2) Select the AUTO mode and confirm that NAVpilot controls the vessel properly.
- Helm sensor test
  - 1) Select [HELM SENSOR TEST] on the [DIAGNOSTIC] menu.
  - 2) Select [YES] to start the helm sensor test.
  - 3) Center the rudder then push the knob to show the pop-up message.
  - 4) Turn the helm to port, and then confirm that “PORT“ is shown at [UNIVERSAL INPUT1].
  - 5) Turn the helm to starboard, and then confirm that “STBD“ is shown at [UNIVERSAL INPUT2].

The example of the test result is shown as below.

HELM SENSOR TEST  
UNIVERSAL INPUT1: STBD\*  
UNIVERSAL INPUT2: PORT\*  
  
PUSH ANY KEY TO CONTINUE

\*: “--“ is shown when the helm sensor test is failed.

- Confirmation of the power assist feature

**Note:** When [POWER ASSIST] is set to [ON], do the following procedure.

  - 1) When [POWER ASSIST STBY] is set to [ON], select the STBY mode. When [POWER ASSIST STBY] is set to [OFF], select the AUTO mode.
  - 2) Turn the helm to port slowly, and then confirm visually that the rudder turns the port side.
  - 3) Turn the helm to starboard slowly, and then confirm visually that the rudder turns to starboard.
- Confirmation of the safe helm feature

**Note:** When [SAFE HELM] and [POWER ASSIST] is set to [ON], do the following procedure.

  - 1) Select the AUTO mode.
  - 2) Select the safe area and cruise at minimum speed.
  - 3) Turn the helm and adjust the response value at [SAFEHELM RESPONSE].
  - 4) While turning the helm, confirm that the power assist feature does not work too strongly. If necessary, adjust the value at [POWER ASSIST REDDER SPEED].
  - 5) Center the rudder and stop steering. Then the steering mode is changed to the AUTO mode automatically. Adjust the return delay at [RETURN DELAY].

- 6) Set the ship's speed to the value set at [FOR SPEEDS UNDER].
- 7) Turn the helm, and then confirm that the safe helm and power assist feature activate correctly.
 

**Note:** Do not turn the helm rapidly. If the power assist feature works strongly, the rudder can be turned more greatly than the turn as intended. [POWER ASSIST RUDDER SPEED].
- 8) Turn the helm and adjust the response at [SAFEHELM RESPONSE].
- 9) When it is difficult to cruise at the speed set at step 6, adjust the setting value at [FOR SPEEDS UNDER] so that you can control the vessel easily.

## 3.6 CAN bus Port Setup

The [CAN BUS SETUP] menu sets up the equipment connected to the CAN bus port.

```

CAN BUS SETUP
DEVICE LIST
INCOMING CAN BUS DATA
SELECT OUTPUT PGN LIST
REFRESH: NO
  
```

1. The cursor is selecting [DEVICE LIST]; push the knob.

```

DEVICE LIST
PG-700: 0019E4
  
```

This display shows the name of the CAN bus equipment connected to the CAN bus port. (In the example illustration, the FURUNO Heading Sensor PG-700 is connected. The series of alphanumeric characters which follow the model name are the CAN bus unique number.) The name of the device can be changed. If you do not need to change the name, go to step 3.

2. To change the device name, do the following:

- 1) Push the knob.
- 2) Rotate the knob to select character then push the knob.
- 3) The cursor moves to the next character. Repeat step 2 to change the character.
 

You can select the input location with the ◀ and ▶ keys. The name can have a maximum of 14 characters.

3. Press the **MENU** key to go back to the [CAN BUS SETUP] menu.

4. Rotate the knob to select [INCOMING CAN BUS DATA] to show the following display.

```

INCOMING CAN BUS DATA
059904 060928 126208 126464 126992
126996 127250 127251 127258 127488
127489 128259 128267 129025 129026
129029 129033 129283 129284 129285
130306 130310 130311 130312 130313
130314 130577
  
```

This display shows all the NMEA 2000 sentences that the NAVpilot is capable of receiving. The Parameter Group Number (PGN) the NAVpilot is currently receiving are highlighted.

5. Press the **MENU** key to go back to the [CAN BUS SETUP] menu.

### 3. INITIAL SETTINGS

6. Rotate the knob to select [SELECT OUTPUT PGN LIST], and the display looks something like the one shown below.

Example for NAVpilot-700

CAN BUS	
126992: OFF	127237: ON
127245: OFF	127250: OFF
127251: OFF	127258: OFF
128259: OFF	128267: OFF
129025: OFF	129026: OFF
129029: OFF	129033: OFF
129283: OFF	129284: OFF
129285: OFF	130306: OFF
130310: OFF	130311: OFF
130312: OFF	
SYSTEM TIME*	

\*: The PGN title of the selected PGN is displayed.

This display shows all the NMEA 2000 sentences that can be output to the NAVpilot. The sentences selected for output show "ON". To turn a sentence ON or OFF, go to step 7. (Corresponding equipment must be connected to turn a sentence ON.) If you do not need to change the settings, go to step 8.

**Note:** Turn OFF the sentence "127245 (rudder)" in case of Fantum Feedback™.

7. To turn an NMEA 2000 sentence on or off, do the following:

- 1) Rotate the knob to select a sentence then push the knob.



- 2) Rotate the knob to select [ON] or [OFF] then push the knob.

8. Press the **MENU** key to return to the [CAN BUS SETUP] menu.

9. Rotate the knob to select [REFRESH] then push the knob.

10. Wait five seconds to allow the system to refresh the device list.

## 3.7 NMEA0183 Port Setup

NMEA0183 SETUP	
PORT1	
PORT2*	

\*: Not shown when [BOAT TYPE] is set to [VOLVO EVC BOAT]

1. The cursor is selecting [PORT1]; push the knob.

NMEA0183 PORT1	
NAMING:	PORT1
OUTPUT FMT:	NMEA0183 V3.0
BAUDRATE:	4800BPS
SELECT OUTPUT SENTENCE	
INCOMING NMEA0183 DATA	

2. The cursor is selecting [NAMING: PORT1]. This menu item lets you change the name of the port. For example, equipment type, model number, etc. The name can have a maximum of 14 alphanumeric characters. If you don't need to change the name, go to step 3.

- 1) Push the knob.
- 2) Rotate the knob to select character then push the knob.
- 3) The cursor moves to the next character. Repeat step 2 to change the character.  
You can select the input location with the ◀ and ▶ keys.
3. Rotate the knob to select [OUTPUT FMT] then push the knob.
4. Rotate the knob to select the output format of the equipment then push the knob.
5. Rotate the knob to select [BAUDRATE] then push the knob.
6. Rotate the knob to select the baud rate of the equipment then push the knob.
7. Rotate the knob to select the [SELECT OUTPUT SENTENCE] then push the knob.  
One of the following displays appears depending on the NMEA output format selected.

NMEA0183 V1.5
NMEA0183 V2.0
NMEA0183 V3.0

4800BPS
38400BPS

VER 1.5		
DBT: OFF	GGA: OFF	GLL: OFF
HDM: OFF	HDT: OFF	MTW: OFF
RMB: OFF	RMC: OFF	ROT: OFF
VHW: OFF	VTG: OFF	VWR: OFF
VWT: OFF	ZDA: OFF	

VER 2.0		
DBT: OFF	DPT: OFF	GGA: OFF
GLL: OFF	HDG: OFF	HDT: OFF
MTW: OFF	MWV: OFF	RMB: OFF
RMC: OFF	ROT: OFF	RSA*: OFF
VHW: OFF	VTG: OFF	VDA: OFF

VER 3.0		
DBT: OFF	DPT: OFF	GGA: OFF
GLL: OFF	GNS: OFF	HDG: OFF
HDT: OFF	MTW: OFF	MWV: OFF
RMB: OFF	RMC: OFF	ROT: OFF
RSA*: OFF	VHW: OFF	VTG: OFF
ZDA: OFF		

\*: Turn OFF the sentence "RSA" in case of Fantum Feedback™.

8. To turn a sentence ON or OFF, rotate the knob to select the sentence, push the knob, rotate the knob to select [ON] or [OFF] then push the knob.
9. Press the **MENU** key to return to the [NMEA0183 PORT1] menu.
10. Rotate the knob to select [INCOMING NMEA0183 DATA] then push the knob.

INCOMING NMEA0183 DATA					
AAM	DBT	HDG	RMB	VHW	ZDA
APB	DPT	HDM	RMC	VTG	
BOD	GGA	HDT	ROT	VWR	
BWC	GLL	MTW	THS	VWT	
BWR	GNS	MWV	TLL	XTE	

This display shows the NMEA0183 sentences currently being received.

11. Press the **MENU** key twice to return to the [NMEA0183 PORT SETUP] menu.  
If you have equipment connected to NMEA0183 PORT2, set up the equipment similar to how you set up the equipment in NMEA0183 PORT1.  
**Note:** [PORT2] is not shown when [BOAT TYPE] is set to [VOLVO EVC BOAT].

## 3.8 Sensor Setup

Before doing this procedure, turn on all CAN bus equipment connected to the CAN bus network of the NAVpilot.

```
SENSOR SELECTION
SENSOR SYNC: ON
HEADING SENSOR
SPEED (STW)
SPEED (SOG)
POSITION SENSOR
WIND SENSOR
DEPTH SENSOR
TEMP SENSOR
```

### SENSOR SYNC

1. The cursor is selecting [SENSOR SYNC]; push the knob.
2. Select [ON] or [OFF] to push the knob.

When [SENSOR SYNC] is set to [ON], the sensors connected to NavNet 3 or NavNet TZtouch devices are available for NAVpilot.

### HEADING SENSOR

1. Turn on all sensors then push the knob.
2. The cursor is selecting [HEADING SENSOR]; push the knob.

```
HEADING SENSOR
AUTO DETECT : NO
1ST: PG-700 : 0019E4
2ND: -----
3RD: -----
```

When [AUTO DETECT] is selected to [YES], all the heading sensors connected to the NAVpilot are shown. In case of multiple heading sensors, the sensors are ordered by FURUNO CAN bus heading sensor, other CAN bus heading sensor, NMEA 0183 heading sensor. If desired you can change the order; select number, push the knob, rotate the knob to select a sensor then push the knob. [AUTO DETECT] automatically re-orders sensors in the above-mentioned order. Select [YES] at [AUTO DETECT] to re-order.

3. Set up speed, position, wind, depth and temp sensors similarly.

## 3.9 Universal Port Setup

```

UNIVERSAL PORT
IN PORT1: DISABLE
IN PORT2: DISABLE
OUT PORT1: DISABLE
OUT PORT2: DISABLE
  
```

The [UNIVERSAL PORT] menu sets up the GENERAL IN and GENERAL OUT ports.

**GENERAL IN:** A switch box is connected to this port to control the NAVpilot from a remote location.

**GENERAL OUT:** A buzzer sounds or a lamp lights at a remote location when the specified function is done on the NAVpilot.

If you have equipment connected to only the GENERAL OUT port, go to step 5.

1. The cursor is selecting the setting for [IN PORT1]; push the knob.

```

DISABLE
AP ENABLE
GO STBY
GO AUTO
PORT ARROW KEY
STBD ARROW KEY
NET TOWING AUTO
FUNCTION KEY
  
```

2. Rotate the knob to select the command or function for [IN PORT1]. This is the command or function assigned to the switch box connected to this port.

[DISABLE]: The port is disabled.

[AP ENABLE]: Select ON to get full control of the boat with the NAVpilot. In the OFF setting only the STBY mode is available.

[GO STBY]: The switch, when operated, puts the NAVpilot in the STBY mode.

[GO AUTO]: The switch, when operated, puts the NAVpilot in the AUTO mode.

[PORT ARROW KEY]: The switch, when operated, controls the ◀ key on the NAVpilot.

[STBD ARROW KEY]: The switch, when operated, controls the ▶ key on the NAVpilot.

[NET TOWING AUTO]: The switch, when operated, enables the automatic towing function when a boat is towing fishing gear. This feature is not available in the following case.

- For a sailboat or Fantum Feedback™
- When [NET TOWING AUTO] is set to [ON] in the menu for each mode or [AUTO OPTION] menu

[FUNCTION KEY]: Assign function of equipment connected to NAVpilot. For a sailboat, this feature is not available.

### 3. INITIAL SETTINGS

3. If you selected [FUNCTION KEY], do the following to select a function. If not go to step 4.

1) Rotate the knob to select [FUNC KEY] then push the knob.

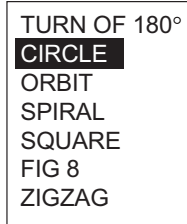

**Note:** For Fantum Feedback™, when the [INPORT 1] or [INPORT 2] is selected to [FUNC KEY], only the [TURN 180°] is selective.

2) Rotate the knob to select an option then push the knob.

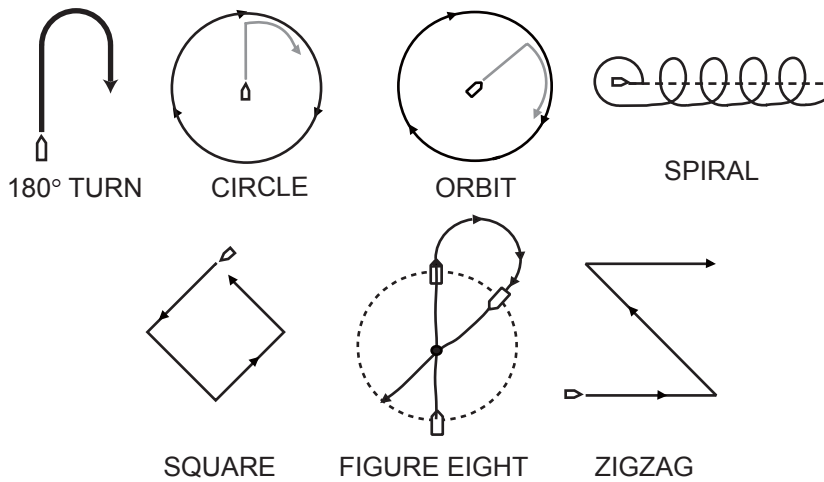

3) Rotate the knob to select [PORT/STBD] then push the knob.



4) Rotate the knob to select the direction of the turn then push the knob.

4. If you have another device connected to the UNIVERSAL IN port, set it up at [IN PORT2].

5. Rotate the knob to select [OUT PORT1] then push the knob.

	A lamp lights or an external buzzer sounds when;
EXT BUZZER*	
STBY MODE	the NAVpilot goes into the STBY mode.
AUTO MODE	the NAVpilot goes into the AUTO mode.
NAV MODE	the NAVpilot goes into the NAV mode.
AUTO/NAV MODE	the NAVpilot switches between the AUTO and NAV modes and vice versa.
AP CONTROL	the rudder is moved.
PORT ARROW KEY	the PORT arrow key (◀) on the NAVpilot is operated
STBD ARROW KEY	the STBD arrow key (▶) on the NAVpilot is operated.
<b>DISABLE</b>	Function disabled.

\* The [BUZZER] setting on the [ALARM] menu is automatically selected to [INTERNAL+EXTERNAL].  
Applicable to both OUT PORT1 and OUT PORT2.

6. Rotate the knob to select the action that triggers an external buzzer or lamp then push the knob.

7. If you have another device connected to the UNIVERSAL OUT port, set it up at [OUT PORT2].



## 3.10 Sea Trial

Other than Fantum Feedback™

SEA TRIAL	
MAG. VAR.:	<b>AUTO</b> --.-°
COMPASS SETUP	
SET CENTER RUD. POS.	
RUDDER DEADBAND*: AUTO	
COG --.-°	HDG: T178°

For Fantum Feedback™

SEA TRIAL	
MAG. VAR.:	<b>AUTO</b> --.-°
COMPASS SETUP	
COG --.-°	HDG: T178°

\* Set to AUTO to do rudder test.  
Set to MANUAL to adjust rudder deadband. See page 3-10.

With a magnetic heading sensor (PG-500/700 etc.), magnetic variation information is necessary to display true heading data. In almost all cases, a GPS will be connected to the NAVpilot and the GPS will send this variation information to the NAVpilot automatically. Therefore, select "AUTO". In special cases where a manual variation is required, you may input these values manually. Note that this selection is only effective when the heading indication for the NAVpilot is selected to "TRUE".

When true heading display is selected in the [DISPLAY SETUP] menu, the NAVpilot will display true heading information even though the NAVpilot may be connected to a magnetic heading sensor. This is very valuable when connecting a FURUNO radar FAR-21X7 series to the NAVpilot because these radars cannot be set for a magnetic heading input and the "Waypoint Lollipop" will only align properly when true heading is used.

**If you have selected the FURUNO PG-500/700 as a heading sensor**, do the procedure below to calibrate the compass and get automatic distortion compensation. Otherwise, go to step 4.

- The procedure is not applicable to other heading sensors.
- It is not necessary to perform any adjustments locally at the PG-500/700. NAVpilot has full control of these heading sensors.

1. Rotate the knob to select [COMPASS SETUP] then push the knob.

COMPASS SETUP	
SELECT COMPASS:	<b>1ST</b>
COMPASS CALEB.:	NO
AUTO CALIB. UPDATE:	ON
COMPASS OFFSET :	E 0.0°
RESTART PG-700*	
COMPASS CLEAR:	NO*2
COMPASS INFORMATION	
COG --.-°	HDG: T178°

\*1 Appears with connection of PG-700.  
Restarts PG-700. Turn the steering mode to the STBY mode to restart PG-700.

\*2 Appears with connection of PG-500, PG-700.  
Restores sensor's factory defaults. For recalibrating compass.

2. [SELECT COMPASS] is selected to [1ST]. Calibrate the 1st compass and then calibrate others.

### 3. INITIAL SETTINGS

1) Rotate the knob to select [COMPASS CALIB.] then push the knob.



\*: Not shown in case of Fantum Feedback™.

2) Rotate the knob to select [AUTO] or [MANUAL] then push the knob.

**AUTO:** The boat turns to starboard about three or four full circles for calibration. Note that the boat will turn to starboard with the degree set at [MANUAL RUDDER LIMIT] on the [DOCKSIDE SETUP] menu.

**MANUAL:** Use the helm to turn the boat to port or starboard for three or four full circles in a speed of about one minute/circle to perform the calibration.

3) Push the knob to start the calibration.

For [AUTO], the boat starts to turn to starboard, and then the calibration starts automatically. For [MANUAL], turn the boat to starboard or port in a circular course. Take about two minutes to complete the circle.

- To stop the calibration while the ship is turning, press any key to show the message "CALIBRATION STOPPED". Press any key again to return to the [SEA TRIAL] menu.
- When the calibration is successfully completed, the message "CALIBRATION COMPLETED" appears. Press any key to return to the [SEA TRIAL] menu.
- If the calibration failed, the message "CALIBRATION NOT COMPLETED. RETRY CALIBRATION?" appears. Push the knob to redo the calibration, or press any key to escape.

4) Rotate the knob to select [AUTO CALIB. UPDATE] then push the knob.

5) Rotate the knob to select [ON] then push the knob. The AUTO LED lights on the PG-500.

3. If you have another PG-500/700, select it at [SELECT COMPASS] and calibrate it following the above procedure.

4. If the heading data shown on the Control Unit differs from the indication of the ship's compass, apply an offset at [COMPASS OFFSET]. This offset is applied to the heading sensor data. For example, if the Control Unit display shows 125° though the ship's compass reading is 120°, for example, enter "5".

1) Rotate the knob to select [COMPASS OFFSET] then push the knob.

2) Rotate the knob to set a value (setting range: E0.0°-E180.0°, W0.1°-W179.9°) then push the knob.

5. [COMPASS INFORMATION] shows the name and software version of the compass connected to the NAVpilot. Select it and push the knob to show compass information, provided your compass outputs such information.

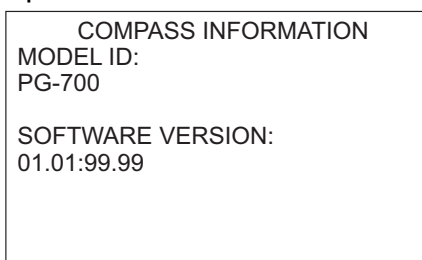

6. Press the **MENU** key to return to the [COMPASS SETUP] menu.
7. Rotate the knob to select [SET CENTER RUDDER POS] then push the knob.  
You must set the rudder position at zero degrees on the [SEA TRIAL] menu. If this setting is not completely, the boat may wander. For dual-engine boats, be sure that the engines are synchronized and maintain a normal cruising speed.

FOLLOW STRAIGHT COURSE AND PUSH ENTER TO SET ARE YOU SURE?	
YES <input type="button" value="ENTER"/>	NO <input type="button" value="MENU"/>

8. Run the boat between 10 and 15 knots (your cruising speed).
9. When the ship runs straight, push the knob to set.

### 3.11 Data Calibration

The [DATA CALIBRATION] menu lets you apply an offset to speed, wind, temperature and depth data. If the indication on the Control Unit differs from actual value apply and offset to correct the indication. Current indications on the Control Unit appears in parentheses.

DATA CALIBRATION	
STW: <input type="text" value="0"/> ° %	( --- kn )
WIND ANG: 0.0°	(---.- ° ) A
WIND SPD: 0.0kn	
	0% (--- kn ) A
TEMP: 0°F	(---.- °F )
DEPTH: 0ft	(--- ft )

1. Rotate the knob to select the sensor you want to compensate then push the knob.
2. Rotate the knob to set a value then push the knob. Enter a negative value when the indication is higher than the actual value; a positive value when it is lower than the actual value. For example, if the depth indication is 100 feet and the actual depth is 98 feet, enter -2.

Item	Range of compensation	Item	Range of compensation
STW*	-50 - +50(%)	TEMP	-10 - +10(°C), -18 - +18(°F)
WIND ANG	-180.0 - +180.0(°)	DEPTH	-15 - +100(ft/m/fa/PB)
WIND SPD	-5 - + 5 (kn, km/h, m/s, mph) or -50 - +50(%)		

\*STW=Speed Through Water

3. Press the **▶** key to show the [PARAMETER SETUP] menu, which adjust the NAVpilot according to sea state, trim, etc.

## 3.12 PARAMETER SETUP Menu

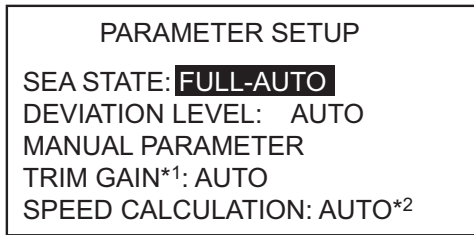

NAVpilot-700

\*1: Not shown in case of Fantum Feedback™.

\*2: Appears on page 2 of menu for NAVpilot-711/720.

### Sea state

Your NAVpilot has an automatic adjustment feature which sets up the equipment according to ship's characteristics and sea state, for optimum performance in the AUTO, NAV and WIND modes. In addition, a self-learning algorithm is incorporated: Parameters for rudder ratio, counter rudder and auto trim gain are constantly optimized based on the steering history of your boat, and are stored in memory for future navigation.

Set how the NAVpilot steers your boat as follows:

1. Rotate the knob to select [SEA STATE] then push the knob.



2. Rotate the knob to select the option which best matches current sea state then push the knob. For items other than [FULL-AUTO], go to step 4.

[FULL-AUTO]: Auto adjustment and self-learning are on.

[SEMI-AUTO]: Auto adjustment is on, self-learning is off.

[MANUAL-CALM]: Self-learning is off, using the parameter selected for calm sea.

[MANUAL-MODERATE]: Self-learning is off, using the parameters for a typical normal sea state.

[MANUAL-ROUGH]: Self-learning is off, using preset parameters for a typical rough sea state.

For normal, everyday operation, the [FULL-AUTO] mode is recommended. However, if you want the NAVpilot to steer the boat based on experience-related parameters, but you don't want the pilot to be in "self-learning" mode, choose the [SEMI-AUTO] option.

Note that the course keeping quality may be decreased if the sea state is different from the experience-related parameters. This option is provided if you happen to be using the pilot in a situation that you do not anticipate encountering again.

3. For [FULL-AUTO], set the deviation level as follows:

- 1) Rotate the knob to select [DEVIATION LEVEL] then push the knob.



- 2) Rotate the knob to select [AUTO] or [LEVEL]. For [LEVEL], you may set a value between 1 and 9. A lower number keeps the course more precisely but the rudder

may be turned more often. With a higher number, the rudder turns slowly, but the course may not be kept as precisely.

- 3) Push the knob to confirm setting.

### **How to manually set NAVpilot steering parameters**

When [MANUAL-CALM], [MANUAL-MODERATE] or [MANUAL-ROUGH] is selected as the sea state, set [MANUAL PARAMETERS] as below.

You can set three parameters for the MANUAL function: Weather, Rudder gain and Counter rudder.

1. Rotate the knob to select [MANUAL PARAMETERS] from the [PARAMETER SETUP] menu then push the knob. The display now looks like the one shown below.

	[CALM]	[MODERATE]	[ROUGH]
[WEATHER]	1°	2°	3°
[RUDDER GAIN]	3	5	10
[COUNT RUDDER]	1	2	4

2. Rotate the knob to select the setting of [WEATHER-CALM] then press the knob.
3. Rotate the knob to set value (0° to 10° for weather).
4. Push the knob.
5. Set [WEATHER-MODERATE], [WEATHER-ROUGH] and [RUDDER GAIN] and [COUNT RUDDER] similarly (Setting range: 1-20 for rudder gain, 0-20 for counter rudder).
6. Press the **MENU** key to finish.

### **Guidelines for how to set SEA STATE**

**[WEATHER]:** When the sea is rough, the boat's heading fluctuates to port and starboard. If the rudder is driven very often to maintain the set course, the helm mechanism may wear out. To prevent this, the weather adjustment makes the NAVpilot insensitive to minute course deviations. You may choose a degree between 0° to 10°. Until the course deviation exceeds the selected setting, steering to correct the heading will not be initiated.

The illustration shown right shows boat's track lines with weather setting 3° and 7°. When 7° is set, for example, the rudder is not driven until the course deviation exceeds 7°. Increasing the setting reduces activation of the steering gear, however the boat tends to zigzag. When the sea is calm, set a smaller value.

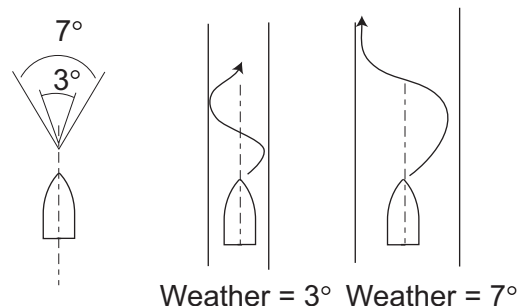

**[RUDDER GAIN]:** When the boat's heading deviates from the set course, the NAVpilot adjusts the rudder to correct it. The rudder angle (number of degrees) which is steered against every degree of course deviation is known as the rudder gain.

### 3. INITIAL SETTINGS

The following illustrations show how many degrees the NAVpilot steers the rudder in order to nullify 4 degrees of course deviation with various settings of the rudder gain.

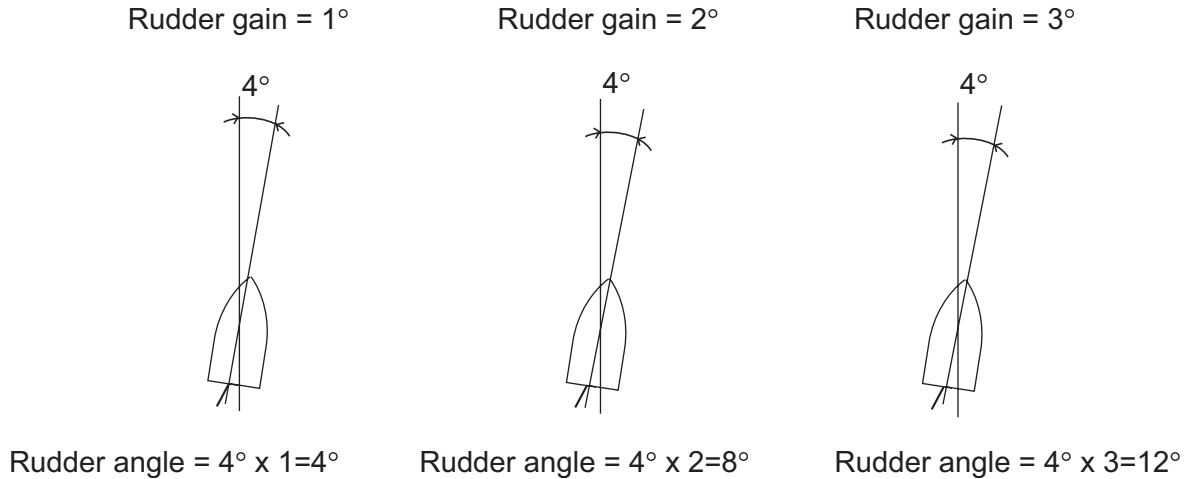

Set rudder gain so that the boat does not make frequent yaw. The figure shown below provides general guidelines for setting rudder gain.

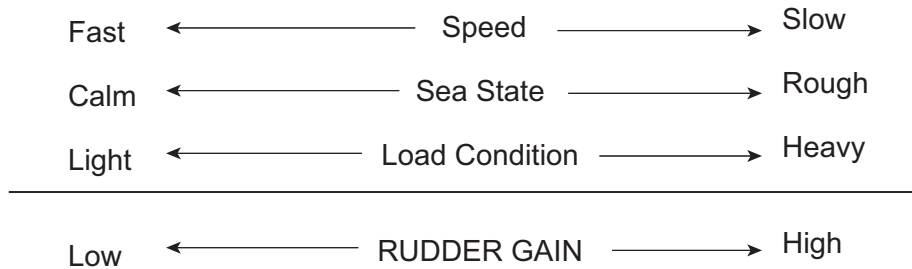

**[COUNT RUDDER]:** If the boat is heavily loaded, the heading could change excessively because of inertia. This phenomenon causes the vessel to "overshoot" the intended course. If this happens, the NAVpilot will steer the rudder to the opposite side and the heading will turn in opposite direction excessively again. In an extreme case the heading oscillates several times until it finally settles in the new course. An adjustment known as "counter rudder" prevents this kind of oscillation.

Counter rudder is usually not required for small boats. When your boat zigzags a lot before settling in the new course, increase the counter rudder setting.

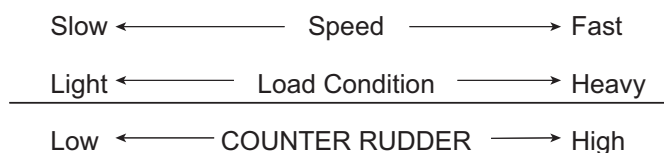
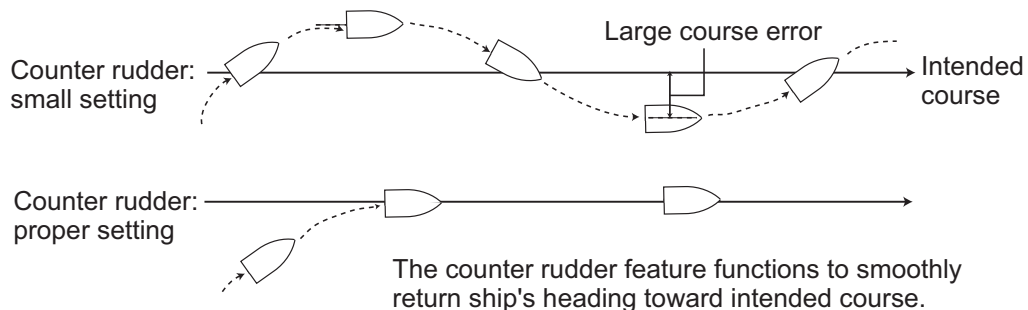

**Trim gain**

**Note:** [TRIM GAIN] is not shown in case of Fantum Feedback™.

The NAVpilot continually monitors the boat's trim in order to keep the trim sensitivity optimum. A lower setting is common because boat's trim usually does not change quickly. A large number changes the trim compensation value more frequently. Too high of a setting may result in the following problems.

- Trim sensitivity is over-affected, resulting that a trim appears in both port and starboard directions alternately.
- Trim compensation mechanism responds to the yawing, resulting in more serious oscillation of ship's heading.

To automatically set the trim, do as follows:

1. Rotate the knob to select [TRIM GAIN] from the [PARAMETER SETUP] menu.



2. Push the knob to show the options for [TRIM GAIN].
3. Rotate the knob to select [AUTO] or [MANUAL] then push the knob. For [AUTO] go to step 4. For [MANUAL] do as follows:
  - 1) Rotate the knob to select the current value and push the knob.
  - 2) Rotate the knob to set a value (1 to 20, the default value is automatically calculated according to length of your boat, entered on the [SHIP'S CHARACTERISTICS] menu.
4. Push the knob to finish.

**Speed calculation**

Speed is normally entered automatically, from your navigator. If the navigator fails, manually enter speed.

1. Rotate the knob to select [SPEED CALCULATION] from the [PARAMETER SETUP] menu.
2. Push the knob to the options for [SPEED CALCULATION].



3. Rotate the knob to select [AUTO] or [MANUAL] then push the knob. For [AUTO] go to step 4. For [MANUAL], do as follows:
  - 1) Rotate the knob to select the current value and push the knob.
  - 2) Rotate the knob to set a value (0.1 - 99.0).
4. Push the knob to finish.

### 3.13 AUTO OPTION Menu

Other than Fantum Feedback™	For Fantum Feedback™
<p>AUTO OPTION</p> <p>ADVANCED AUTO: <b>ON</b></p> <p>NET TOWING AUTO*: OFF</p> <p>CSE AFTER REMOTE: PRESENT COURSE</p>	<p>AUTO OPTION</p> <p>ADVANCED AUTO: <b>ON</b></p>

\*: Not shown when BOAT TYPE is set for "sailboat".

Item	Description	Settings
[ADVANCED AUTO]	The AUTO mode will maintain a set course, but your vessel's course may be shifted by the effects of tide and wind. To compensate for the effects of tide and wind, set [ADVANCED AUTO] to [ON]. Your NAVpilot must be connected to a GPS navigator which outputs position data (Latitude and Longitude) in CAN bus or NMEA 0183 format.	[OFF], [ON]
[NET TOWING AUTO]	When a boat is towing fishing gear its stern is "dragged" by the net. This causes the boat to stray from its intended course. To keep the boat on course, you need to adjust the trim manually, which can be bothersome. If you do not want to be bothered with trim adjustments, you can enable the automatic towing function to have the trim automatically adjusted. This feature is useful for trawlers and purse seiners. Not available for "boat type" "sailboat". <b>Note:</b> [NET TOWING AUTO] is not shown in case of Fantum Feedback™.	[OFF], [ON]
[CSE AFTER REMOTE]	Select the course to follow after a remote controller is operated. See the figure below. <b>Note:</b> [CSE AFTER REMOTE] is not shown in case of Fantum Feedback™.	[PREVIOUS COURSE], [PRESENT COURSE]



## 3.14 NAV OPTION Menu

NAV OPTION
NAV MODE: <b>XTE (ECONOMY)</b>
NAV DATA SOURCE
WAYPOINT SWITCHING: AUTO
AFTER ARRIVAL:
GO STRAIGHT
NAVNET2: ON

Item	Description	Settings
[NAV MODE]	Your vessel may go off course when navigating between waypoints in the NAV mode. This can happen when, for example, a command is received from a remote controller. To get you back on course, three methods are available: [COURSE] and [XTE (PRECISION)], [XTE (ECONOMY)]. For [COURSE], the NAVpilot calculates a new course based on your new position after dodging, etc. that takes you directly to your destination waypoint. [XTE PRECISION] and [XTE ECONOMY] both use the XTE (cross-track error) value to steer the boat towards your ORIGINAL course before dodging. PRECISION provides for more precise steering than ECONOMY. <b>Note:</b> [COURSE] is not shown in case of Fantum Feedback™.	[COURSE], [XTE(PRECISION)], [XTE(ECONOMY)]
[NAV DATA SOURCE]	Select the source of nav data to use in the NAV mode. See the procedure on the next page.	
[WAYPOINT SWITCHING]	When you arrive at a waypoint on a route in the NAV mode, you can switch to the next waypoint automatically or manually. The [AUTO] setting will automatically switch to the next destination waypoint when your boat is within the arrival alarm area (set on the chartplotter). The [MANUAL] setting requires operator confirmation (pushing the knob) before switching to the next waypoint.	[AUTO], [MANUAL],
[AFTER ARRIVAL]	Set how the boat is to be steered after arriving at the last waypoint in a route, in the NAV mode. This function is not available when boat type is selected as sailboat. <b>Note:</b> For Fantum Feedback™, only the items [GO STRAIGHT] and [ORBIT TO STBD] are available.	[GO STRAIGHT], [ORBIT TO PORT]. [ORBIT TO STBD]. [FIGURE EIGHT TO PORT], [FIGURE EIGHT TO STBD], [SQUARE PORT], [SQUARE STBD],
[NAVNET2]	The NAVpilot can automatically go to the NAV mode when it receives a P sentence (FURUNO proprietary) from a NavNet vx2 equipment. You can turn this feature on or off. This feature is invalid when you use the FishHunter™ mode.	[OFF], [ON]

### 3. INITIAL SETTINGS

#### **How to select the source for nav data**

1. At the [NAV OPTION] menu, rotate the knob to select [NAV DATA SOURCE] then push the knob.

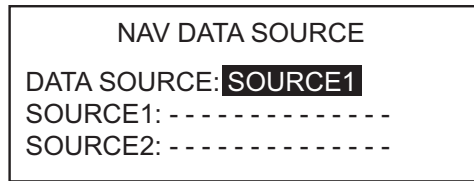

2. Rotate the knob to select [DATA SOURCE] and push the knob.

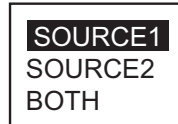

3. Rotate the knob to select source then push the knob. If you have more than one source of nav data, you can select [BOTH]. In this case, the nav data fed by [SOURCE2] is used when that of [SOURCE1] is not available.
4. Rotate the knob to select [SOURCE1] then push the knob.



\*: Not shown when [BOAT TYPE] is set to [VOLVO EVC BOAT].

If you have some equipment which outputs nav data, the name appears in the window. In the example above, a NavNet 3 equipment, with unique number of 000C2F, is connected.

5. Rotate the knob to select source then push the knob. If you have more than one device that outputs nav data, you can select it at [SOURCE2].

**Note:** If you have NavNet vx2 equipment connected and it is synchronized with the NAVpilot ([NAVNET2] turned on in the [NAV OPTION] menu), [SOURCE2] is automatically selected.

### 3.15 FISH HUNTER OPTION Menu or WIND OPTION Menu

Depending on the setting for [SHIP'S CHARACTERISTICS], the [FISH HUNTER OPTION] menu or the [WIND OPTION] menu follows the [NAV OPTION] menu.

#### 3.15.1 FISH HUNTER OPTION menu

The [FISH HUNTER OPTION] menu lets you preset the parameters for the various turns, which you access with the **TURN** key (NAVpilot-700) or **TURN/MENU** key (NAVpilot-711/720).

**Note:** The [FISH HUNTER OPTION] menu is not shown in case of Fantum Feedback™.

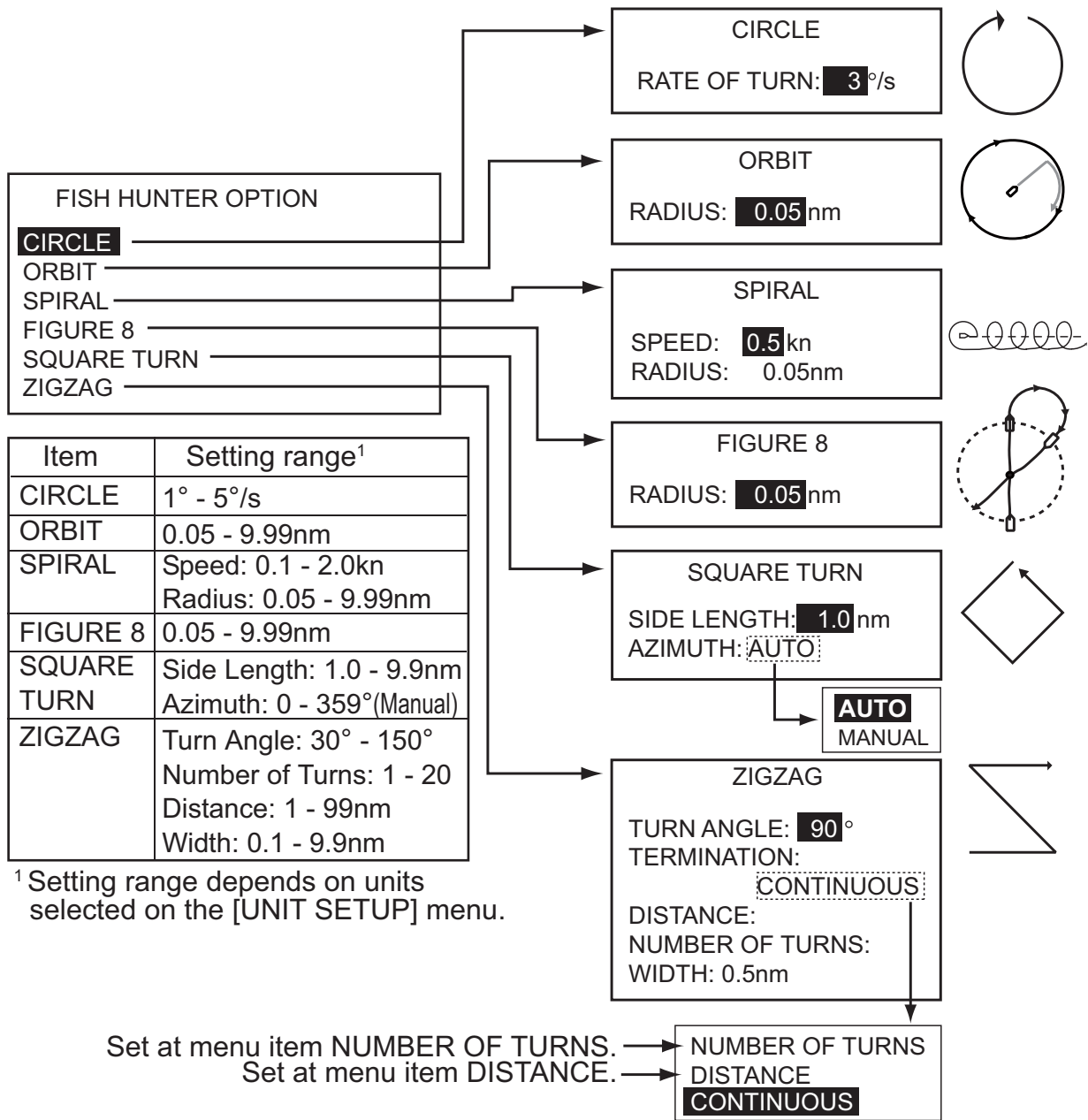

### 3.15.2 WIND OPTION menu

**Note:** The [WIND OPTION] menu is not shown in case of Fantum Feedback™.

WIND OPTION	
MODE TYPE:	<b>AWA</b>
WIND TACK RUD ANGLE:	35°
WIND DAMPING:	ON 5.0SEC
FIXED TACK ANGLE:	100°
RATE OF SLOW TACK:	3°/s
RATE OF FAST TACK:	20°/s
TACK TIMER:	OFF

Item	Description	Settings
[MODE TYPE]	There are three wind angle modes: AWA (Apparent Wind Angle), TWA (True Wind Angle), and AUTO. <b>AWA:</b> The direction (in relation to ship's bow) of the wind as it appears on board your boat, detected by the wind sensor. AWA mode requires wind angle and speed data. Use this mode when wind is stable. <b>TWA:</b> The actual wind direction, which is a combination of the apparent wind and your boat's movement. This mode requires apparent wind angle, apparent wind speed, your boat's speed and heading. Use this mode when there is an unstable downwind.	[AWA], [TWA]
[WIND TACK RUD ANGLE]	The tacking in the WIND mode requires the setting of maximum rudder angle. If you need to change the value, do it here.	10° - 45°
[WIND DAMPING]	You can set the damping interval for wind data to compensate for random fluctuation in wind data. The higher the setting the more "smooth" the data. However a high damping interval causes delay in receiving wind data, the amount of delay equivalent to the damping interval. Turn off wind damping if the wind data is received stably. This option is effective for port and starboard wind angles of 55° or higher and [MODE TYPE] is selected to [AWA].	[OFF], [ON] (0.7 - 99.9)
[FIXED TACK ANGLE]	The fixed tacking mode requires the setting of tacking angle.	15° - 179°
[RATE OF SLOW TACK]	Set the rate of slow tack.	1° - 10°s
[RATE OF FAST TACK]	Set the rate of fast tack.	10° - 30°s
[TACK TIMER]	Set the amount of time to wait before starting a turn, after pushing the knob.	[OFF], [ON] (1 - 99(sec))

After setting all options on the [FISH HUNTER OPTION] menu (or [WIND OPTION] menu), press the ► key to go to the [SYSTEM SETUP] menu. The [SYSTEM SETUP] menu sets system settings such as key beep, panel dimmer, etc.

## 3.16 SYSTEM SETUP Menu

Page 1

SYSTEM SETUP
KEY BEEP: <b>OFF</b>
BUZZER VOL: LARGE
ARROW KEY: DODGE
KEY LOCK: UNLOCK
TURN ANGLE: 15
PANEL DIMMER: 8
PASSWORD: 0000
PASSWORD FUNCTION: OFF
ALARM CLEAR
RECEIVE SCREEN: OFF
SAVE USER SETTING: NO
LOAD USER SETTING: NO
SAVE DISPLAY SETTINGS: NO

Page 2

SYSTEM SETUP
LOAD DISPLAY SETTINGS: NO
SAVE ENGINEER SETTING: NO
LOAD ENGINEER SETTING: NO
ALARM LOG
SIM/DEMO: OFF
DIAGNOSTIC: OFF
DISPLAY DATA SELECT MENU
SYSTEM DATA

**SAVE ENGINEER SETTING:** Save the settings in the menus with the following exceptions:

- DISPLAY SETUP (except DATA BOX FORMAT, TEMP GRAPH)
- DOCKSIDE SETUP (except SELECT RRU TYPE, RRU SENSOR ALIGNMENT, AIR BLEEDING, RUDDER LIMIT SETUP, RUDDER TEST, HELM SENSOR TEST)
- CAN BUS SETUP (except INCOMING CAN BUS DATA, REFRESH)
- NMEA 0183 SETUP PORT1, PORT2 (except REFRESH)
- SENSOR SELECTION (except AUTO DETECT)
- SEA TRIAL (except COMPASS, COMPASS CALIB., RESTART PG-700, COMPASS CLEAR, COMPASS INFORMATION, SET CENTER RUDDER POS)
- SYSTEM SETUP (KEY BEEP, BUZZER VOL, KEY LOCK, PANEL DIMMER, RECEIVE SCREEN, ALL CLEAR, SAVE/LOAD USER SETTINGS, SAVE/LOAD ENGINEER SETTING, DIAGNOSTIC, DISPLAY DATA SELECT MENU, SYSTEM DATA)
- ALARM MENU (CLEAR TRIP LOG)

**LOAD ENGINEER SETTING:** Load the settings saved with SAVE ENGINEER SETTING:

For other items, section 4.6 "SYSTEM SETUP menu" in the Operator's Manual.

## 3.17 RC (Remote Controller) SETUP Menu

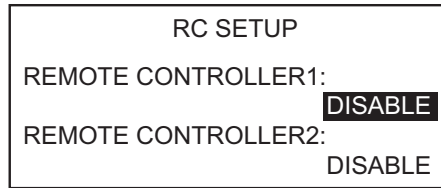

**Note:** The [RC SETUP] menu is not shown in case of Fantum Feedback™.

Set the type of remote controller you have as follows

1. The setting for [REMOTE CONTROLLER 1] is selected; push the knob.
2. Rotate the knob to select the type of remote controller connected.
  - [NFU]:** Select for button- or lever-type remote controller.
  - [FU]:** Select for dial-type remote controller.
  - [DODGE]:** Select for dodge-type remote controller.
  - [DISABLE]:** Disable remote controller operation.
3. Set the type for remote controller 2, if connected.



## 3.18 All Clear

The all clear feature restores all default settings.

1. Push the knob three times while pressing the [MENU] key in the STBY mode.  
The [INSTALLATION] menu appears.
2. Select [SYSTEM SETUP].
3. Select [ALL CLEAR] and [YES] to restore all default settings.

# JIS CABLE GUIDE

Cables listed in the manual are usually shown as Japanese Industrial Standard (JIS). Use the following guide to locate an equivalent cable locally.

JIS cable names may have up to 6 alphabetical characters, followed by a dash and a numerical value (example: DPYC-2.5).

For core types D and T, the numerical designation indicates the *cross-sectional Area (mm<sup>2</sup>)* of the core wire(s) in the cable.

For core types M and TT, the numerical designation indicates the *number of core wires* in the cable.

## 1. Core Type

D: Double core power line  
 T: Triple core power line  
 M: Multi core  
 TT: Twisted pair communications  
 (1Q=quad cable)

## 2. Insulation Type

P: Ethylene Propylene  
 Rubber

## 3. Sheath Type

Y: PVC (Vinyl)

## 4. Armor Type

C: Steel

## 5. Sheath Type

Y: Anticorrosive vinyl  
 sheath

## 6. Shielding Type

S: All cores in one sheath  
 -S: Individually sheathed cores  
 SLA: All cores in one shield, plastic  
 tape w/aluminum tape  
 -SLA: Individually shielded cores,  
 plastic tape w/aluminum tape

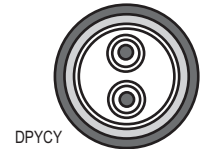

DPYC



TPYC

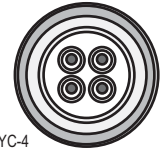

MPYC-4

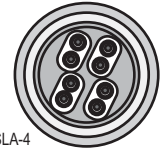

TTYCSLA-4

EX: <sup>1 2 3 4 5 6</sup> TTYCYSLA - 4  
 Designation type Core Area (mm<sup>2</sup>)

EX: <sup>1 2 3 4</sup> MPYC - 4  
 Designation type # of cores

The following reference table lists gives the measurements of JIS cables commonly used with Furuno products:



Type	Core Area	Core Diameter	Cable Diameter	Type	Core Area	Core Diameter	Cable Diameter
DPYC-1.5	1.5mm <sup>2</sup>	1.56mm	11.7mm	TTYCS-1	0.75mm <sup>2</sup>	1.11mm	10.1mm
DPYC-2.5	2.5mm <sup>2</sup>	2.01mm	12.8mm	TTYCS-1T	0.75mm <sup>2</sup>	1.11mm	10.6mm
DPYC-4	4.0mm <sup>2</sup>	2.55mm	13.9mm	TTYCS-1Q	0.75mm <sup>2</sup>	1.11mm	11.3mm
DPYC-6	6.0mm <sup>2</sup>	3.12mm	15.2mm	TTYCS-4	0.75mm <sup>2</sup>	1.11mm	16.3mm
DPYC-10	10.0mm <sup>2</sup>	4.05mm	17.1mm	TTYCSLA-1	0.75mm <sup>2</sup>	1.11mm	9.4mm
DPYCY-1.5	1.5mm <sup>2</sup>	1.56mm	13.7mm	TTYCSLA-1T	0.75mm <sup>2</sup>	1.11mm	10.1mm
DPYCY-2.5	2.5mm <sup>2</sup>	2.01mm	14.8mm	TTYCSLA-1Q	0.75mm <sup>2</sup>	1.11mm	10.8mm
DPYCY-4	4.0mm <sup>2</sup>	2.55mm	15.9mm	TTYCSLA-4	0.75mm <sup>2</sup>	1.11mm	15.7mm
MPYC-2	1.0mm <sup>2</sup>	1.29mm	10.0mm	TTYCY-1	0.75mm <sup>2</sup>	1.11mm	11.0mm
MPYC-4	1.0mm <sup>2</sup>	1.29mm	11.2mm	TTYCY-1T	0.75mm <sup>2</sup>	1.11mm	11.7mm
MPYC-7	1.0mm <sup>2</sup>	1.29mm	13.2mm	TTYCY-1Q	0.75mm <sup>2</sup>	1.11mm	12.6mm
MPYC-12	1.0mm <sup>2</sup>	1.29mm	16.8mm	TTYCY-4	0.75mm <sup>2</sup>	1.11mm	17.7mm
TPYC-1.5	1.5mm <sup>2</sup>	1.56mm	12.5mm	TTYCY-4S	0.75mm <sup>2</sup>	1.11mm	21.1mm
TPYC-2.5	2.5mm <sup>2</sup>	2.01mm	13.5mm	TTYCY-4SLA	0.75mm <sup>2</sup>	1.11mm	19.5mm
TPYC-4	4.0mm <sup>2</sup>	2.55mm	14.7mm	TTYCYS-1	0.75mm <sup>2</sup>	1.11mm	12.1mm
TPYCY-1.5	1.5mm <sup>2</sup>	1.56mm	14.5mm	TTYCYS-4	0.75mm <sup>2</sup>	1.11mm	18.5mm
TPYCY-2.5	2.5mm <sup>2</sup>	2.01mm	15.5mm	TTYCYSLA-1	0.75mm <sup>2</sup>	1.11mm	11.2mm
TPYCY-4	4.0mm <sup>2</sup>	2.55mm	16.9mm	TTYCYSLA-4	0.75mm <sup>2</sup>	1.11mm	17.9mm

# PACKING LIST

64BB-X-9854 -1 1/1

FAP-7001

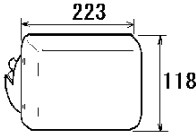
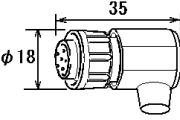
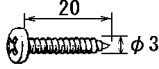
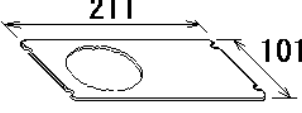
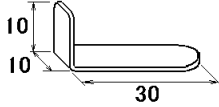
A-1

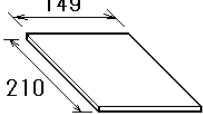
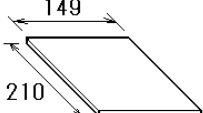
NAME	OUTLINE	DESCRIPTION/CODE No.	QTY
<b>ユニット UNIT</b>			
操作部2D CONTROL UNIT 2D		FAP-7001	1
		000-016-411-00	
<b>付属品 ACCESSORIES FP64-01401</b>			
ターミナルコネクタ TERMINATOR		BD-07AFFM-LR7001	1
		001-081-140-10	
<b>工事材料 INSTALLATION MATERIALS CP64-02900</b>			
+ナベ タッピンネジ 1シ SELF-TAPPING SCREW		3X20 SUS304	4
		000-163-884-10	
マウントスポンジ 2D FLUSH MOUNTING SPONGE 2D		64-028-1013-0	1
		100-352-540-10	
パネルリムーバ PANEL REMOVER		19-028-3124-1	1
		100-340-471-10	
ケーブル組品 CABLE ASSEMBLY		BD-07AFFM-LR-150	1
		001-081-180-10	
<b>図書 DOCUMENT</b>			
取扱説明書 OPERATOR'S MANUAL		OM*-72720-*	1
		000-171-812-1*	
操作要領書(多言) OPERATOR'S GUIDE (MLG)		MLG-72720-*	1
		000-172-121-1*	

型式/コード番号が2段の場合、下段より上段に代わる過渡期品であり、どちらかが入っています。なお、品質は変わりません。

TWO TYPES AND CODES MAY BE LISTED FOR AN ITEM. THE LOWER PRODUCT MAY BE SHIPPED IN PLACE OF THE UPPER PRODUCT. QUALITY IS THE SAME.



(略図の寸法は、参考値です。DIMENSIONS IN DRAWING FOR REFERENCE ONLY.)





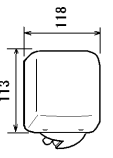
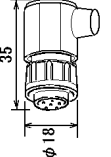
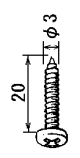
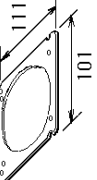
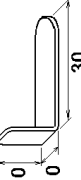

# PACKING LIST FAP-7011

64BB-X-9855-1

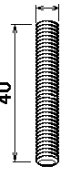
1/1

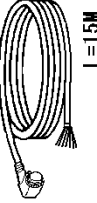
NAME	OUTLINE	DESCRIPTION/CODE No.	Q'TY
<b>UNIT</b>			
ユニット 操作部1D CONTROL UNIT 1D		FAP-7011 000-016-412-00	1
<b>ACCESSORIES</b>			
<b>付属品</b>			
ターミナルコネクタ TERMINATOR		BD-07AFFM-LR7001 001-081-140-10	1
<b>INSTALLATION MATERIALS</b>			
<b>工事材料</b>			
+self タッピンネジ 1ｼｼ SELF-TAPPING SCREW		3X20 SUS304 000-163-884-10	4
Sﾌﾞﾗﾝﾄﾞｽﾌﾟﾝｼﾞ SPONGE		26-001-1012-0 100-352-270-10	1
ﾊﾟﾈﾙﾘﾓﾊﾞｰ PANEL REMOVER		19-028-3124-1 100-340-471-10	1
ﾊﾟﾈﾙ座金 SPRING WASHER		M3 SUS304 000-167-404-10	2
ﾐｶｷ丸平座金 FLAT WASHER		M3 SUS304 000-167-453-10	2

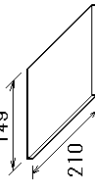
NAME	OUTLINE	DESCRIPTION/CODE No.	Q'TY
寸切ボルト BOLT		M3X40 SUS304 000-167-804-10	2
蝶ナット WING NUT		M3 SUS304 000-167-826-10	2
ケーブル組品 CABLE ASSEMBLY		BD-07AFFM-LR-150 001-081-180-10	1
<b>図書</b>			
<b>DOCUMENT</b>			
取扱説明書 OPERATOR'S MANUAL		OM*-72720-* 000-171-812-1*	1
操作要領書(多言) OPERATOR'S GUIDE (MLG)		MLG-72720-* 000-172-121-1*	1

(略図の寸法は、参考値です。DIMENSIONS IN DRAWING FOR REFERENCE ONLY.)

型式/コード番号が2段の場合、下段より上段に代わる過渡期品であり、どちらが入っています。なお、品質は変わりません。  
TWO TYPES AND CODES MAY BE LISTED FOR AN ITEM. THE LOWER PRODUCT MAY BE SHIPPED IN PLACE OF THE UPPER PRODUCT. QUALITY IS THE SAME.

A-2

C7273-Z01-B

# PACKING LIST

64BB-X-9875 -0 1/1

FAP-7011C

A-3

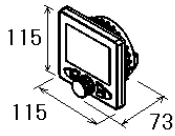
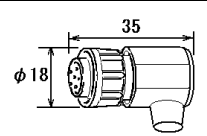
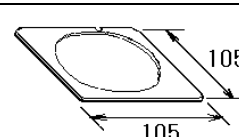
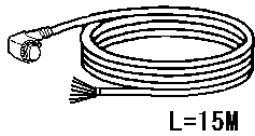
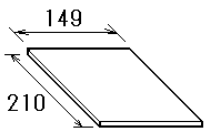
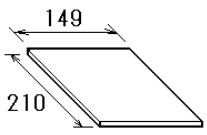
NAME	OUTLINE	DESCRIPTION/CODE No.	QTY
<b>ユニット UNIT</b>			
操作部1D CONTROL UNIT 1D		FAP-7011C 000-023-878-00	1
<b>付属品 ACCESSORIES</b>			
ターミナルコネクタ TERMINATOR		BD-07AFFM-LR7001 001-081-140-10	1
<b>工事材料 INSTALLATION MATERIALS</b>			
スマウントスポンジ SPONGE		TZ8103008A* 999-999-206-00	1
ケーブル組品 CABLE ASSEMBLY		BD-07AFFM-LR-150 001-081-180-10	1
<b>図書 DOCUMENT</b>			
取扱説明書 OPERATOR'S MANUAL		OM*-72780-* 000-178-290-1*	1
操作要領書(多言語) OPERATOR'S GUIDE (MLG)		MLG-72780-* 000-178-291-1*	1

型式/コード番号が2段の場合、下段より上段に代わる過渡期品であり、どちらかが入っています。なお、品質は変わりません。

TWO TYPES AND CODES MAY BE LISTED FOR AN ITEM. THE LOWER PRODUCT MAY BE SHIPPED IN PLACE OF THE UPPER PRODUCT. QUALITY IS THE SAME.

(略図の寸法は、参考値です。DIMENSIONS IN DRAWING FOR REFERENCE ONLY.)

# PACKING LIST

64BB-X-9856 -2 1/1

FAP-7021

A-4

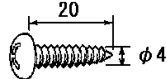
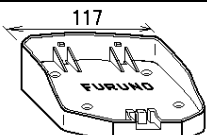
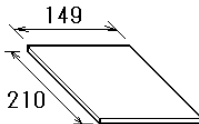
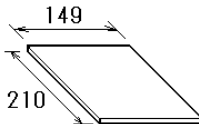
NAME	OUTLINE	DESCRIPTION/CODE No.	QTY
<b>ユニット UNIT</b>			
操作部HANDY CONTROL UNIT HANDY		FAP-7021 000-016-413-00	1
<b>付属品 ACCESSORIES</b>		<b>FP64-01411</b>	
+トラスタップインネジ 1シユ SELF-TAPPING SCREW		4X20 SUS304 000-158-850-10	4
クレードル(N2.5) CRADLE (N2.5)		64-028-4004-1 100-356-481-10	1
<b>図書 DOCUMENT</b>			
取扱説明書 OPERATOR'S MANUAL		OM*-72720-* 000-171-812-1*	1
操作要領書(多言) OPERATOR'S GUIDE (MLG)		MLG-72720-* 000-172-121-1*	1

型式/コード番号が2段の場合、下段より上段に代わる過渡期品であり、どちらかが入っています。なお、品質は変わりません。

TWO TYPES AND CODES MAY BE LISTED FOR AN ITEM. THE LOWER PRODUCT MAY BE SHIPPED IN PLACE OF THE UPPER PRODUCT. QUALITY IS THE SAME.

(略図の寸法は、参考値です。DIMENSIONS IN DRAWING FOR REFERENCE ONLY.)

# PACKING LIST

64BB-X-9857 -5 1/1

FAP-7002 , FAP-7002-11 , FAP-7002-20 , FAP-7002-11C

A-5

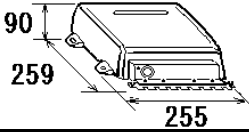
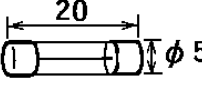
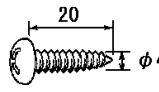
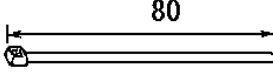
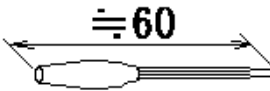
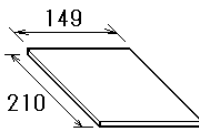
NAME	OUTLINE	DESCRIPTION/CODE No.	Q' TY
<b>ユニット UNIT</b>			
制御部 PROCESSOR UNIT		FAP-7002/-11/-20	1
		000-016-419-00 **	
<b>予備品 SPARE PARTS SP64-01501</b>			
ヒューズ GLASS TUBE FUSE		FGMB 125V 4A PBF	4
		000-157-482-10	
<b>工事材料 INSTALLATION MATERIALS CP64-03101</b>			
+トラスタップンネジ 1シユ SELF-TAPPING SCREW		4X20 SUS304	4
		000-158-850-10	
コンベックス CABLE TIE		CV-80N	20
		000-162-192-10	
テイクウ(組品) RESISTOR ASSEMBLY		120 OHM-1007#24-L50	1
		000-167-746-11	
<b>図書 DOCUMENT</b>			
装備要領書 INSTALLATION MANUAL		IM*-72720-*	1
		000-171-813-1*	

コード番号末尾の[\*\*]は、選択品の代表コードを表します。

CODE NUMBER ENDING WITH "\*\*" INDICATES THE CODE NUMBER OF REPRESENTATIVE MATERIAL.

型式/コード番号が2段の場合、下段より上段に代わる過渡期品であり、どちらかが入っています。なお、品質は変わりません。

TWO TYPES AND CODES MAY BE LISTED FOR AN ITEM. THE LOWER PRODUCT MAY BE SHIPPED IN PLACE OF THE UPPER PRODUCT. QUALITY IS THE SAME.

(略図の寸法は、参考値です。DIMENSIONS IN DRAWING FOR REFERENCE ONLY.)

C7272-Z02-F

表1 TABLE 1

寸法区分 (mm) DIMENSION	公差 (mm) TOLERANCE
L ≤ 50	±1.5
50 < L ≤ 100	±2.5
100 < L ≤ 500	±3

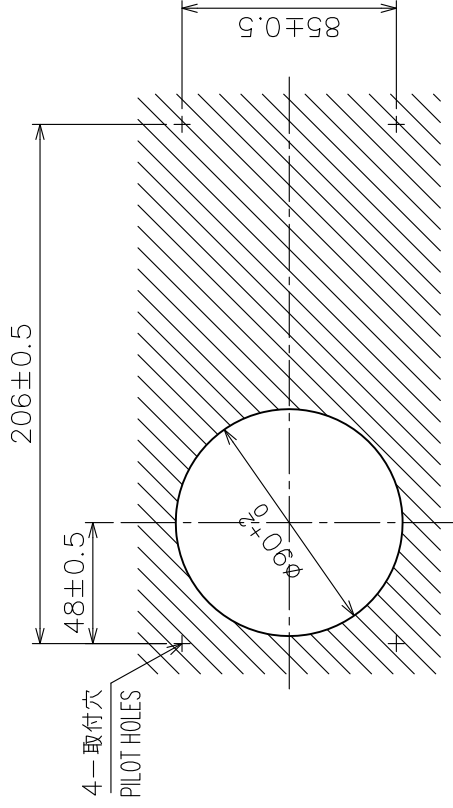

取付穴寸法図

CUTOUT DIMENSIONS

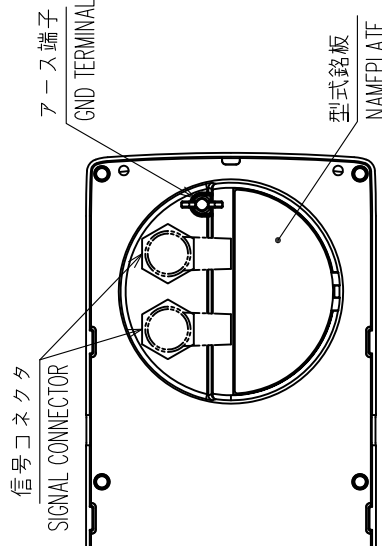
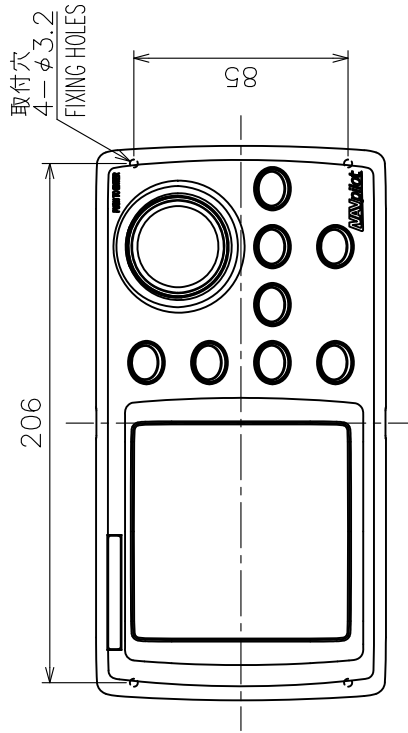
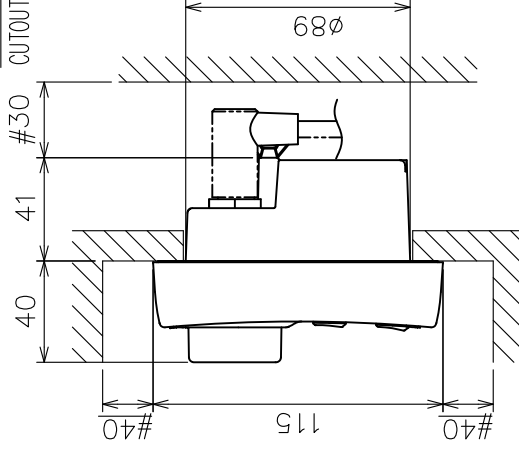

注 記

- 1) 指定外の寸法公差は表1による。
- 2) #印寸法は最小サービスマウントとする。
- 3) 取付用ネジはナベタツピコンネジ呼び径3×2.0を使用のこと。

NOTE

1. TABLE 1 INDICATES TOLERANCE OF DIMENSIONS WHICH IS NOT SPECIFIED.
2. #: MINIMUM SERVICE CLEARANCE.
3. USE TAPPING SCREWS φ3x2.0 FOR FIXING THE UNIT.

DRAWN	9/Nov/09	I.YAMASAKI	TITLE	FAP-7001
CHECKED	9/Nov/09	I.TAKENO	名称	操作部 (サーフェスマウント)
APPROVED	24/Nov/09	R. Esumi	外寸図	
SCALE	1/100	質量はケーブルを含む。	NAME	CONTROL UNIT (SURFACE MOUNT)
DWG.No.	C7272-G01-A	REF.No.	64-028-100G-3	OUTLINE DRAWING



表1 TABLE 1

寸法区分 (mm) DIMENSION	公差 (mm) TOLERANCE
L ≤ 50	±1.5
50 < L ≤ 100	±2.5
100 < L ≤ 500	±3

注記

- 1) 指定外の寸法公差は表1による。
- 2) #印寸法は最小サービスマウントとする。
- 3) 取付用ネジはナベタツピンネジ呼び径3×20を使用のこと。

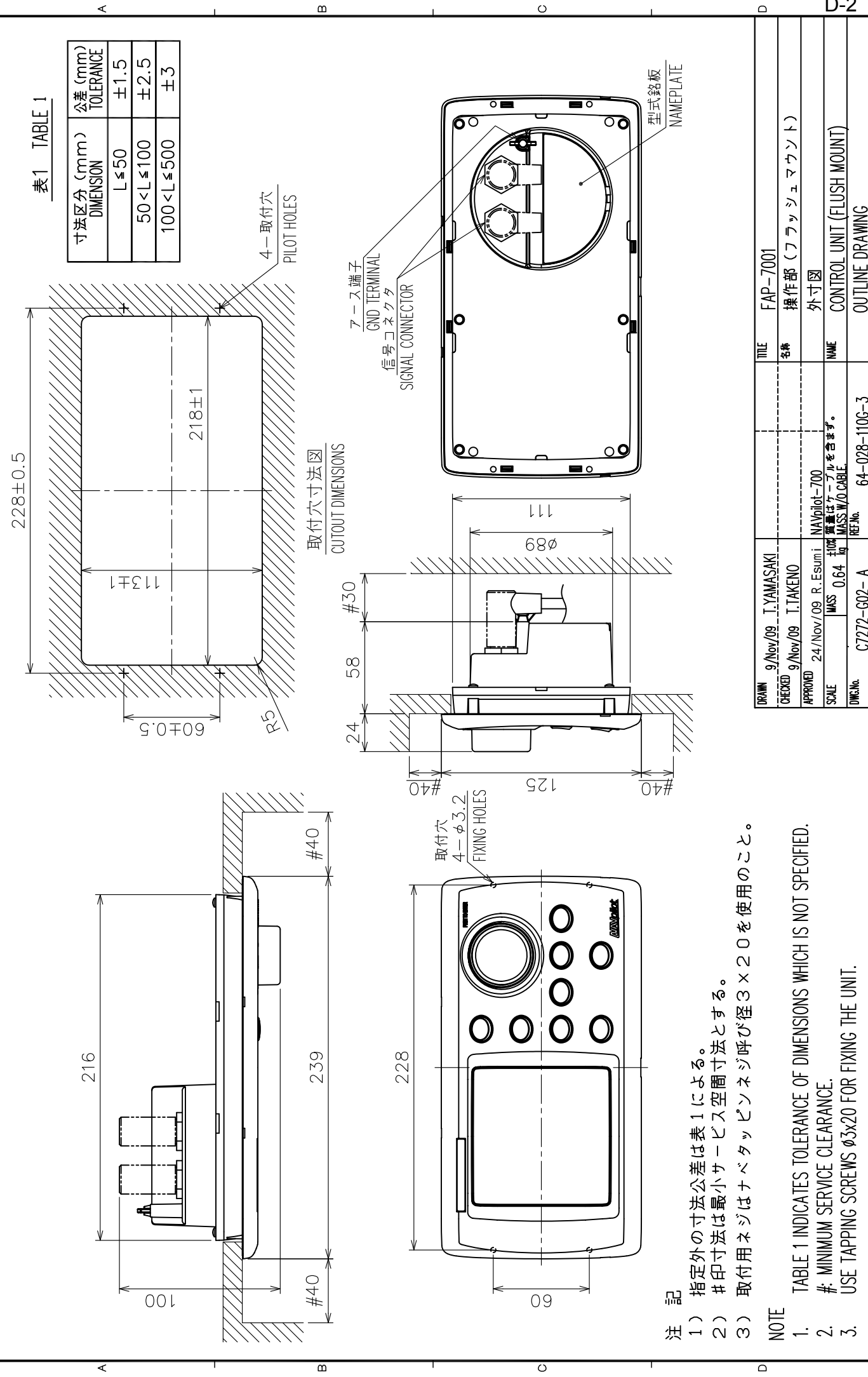
NOTE

1. TABLE 1 INDICATES TOLERANCE OF DIMENSIONS WHICH IS NOT SPECIFIED.
2. # MINIMUM SERVICE CLEARANCE.
3. USE TAPPING SCREWS φ3x20 FOR FIXING THE UNIT.

DRAWN	9/Nov/09	I. YAMASAKI	TITLE	FAP-7001
CHECKED	9/Nov/09	I. TAKENO	名称	操作部 (フラッシュマウント)
APPROVED	24/Nov/09	R. Esumi	外寸図	
SCALE	1/100	質量はケーブルを含まず。 MASS W/O CABLE.	NAME	CONTROL UNIT (FLUSH MOUNT)
DWG.No.	C7272-G02-A	REF.No.	64-028-110G-3	OUTLINE DRAWING

表1 TABLE 1

寸法区分 (mm) DIMENSION	公差 (mm) TOLERANCE
L ≤ 50	±1.5
50 < L ≤ 100	±2.5
100 < L ≤ 500	±3

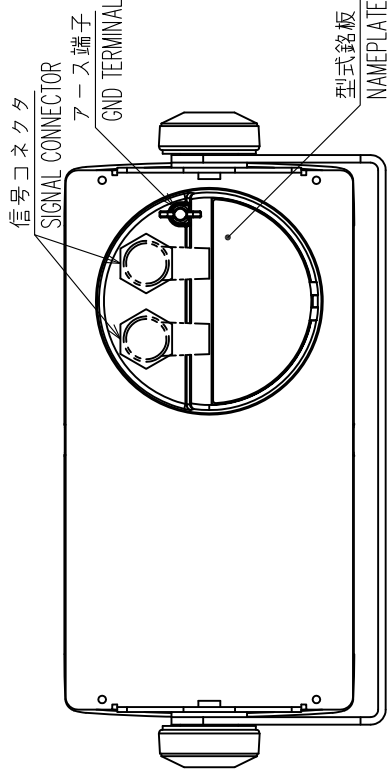

背面  
REAR VIEW

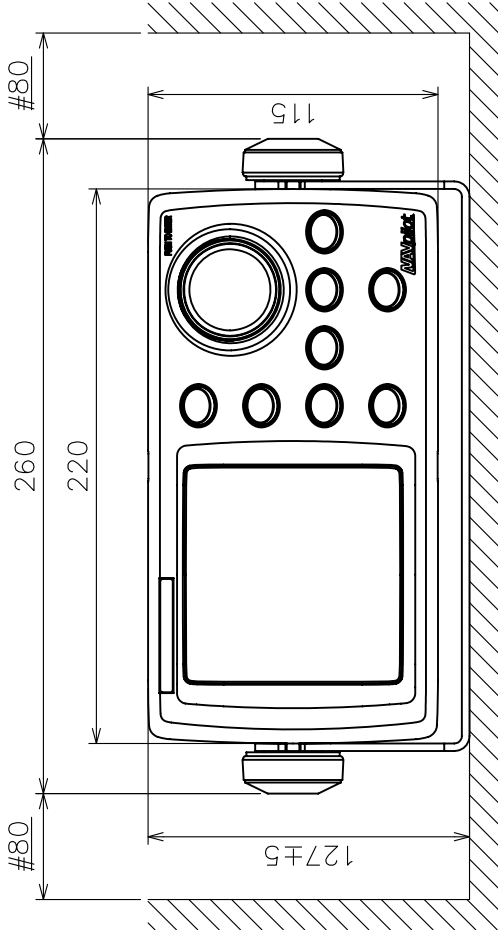
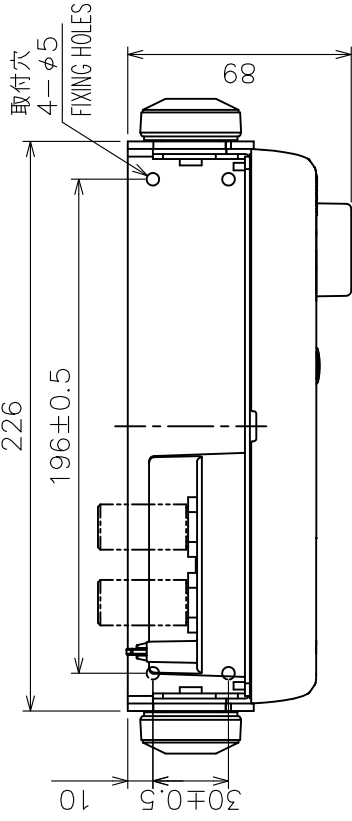
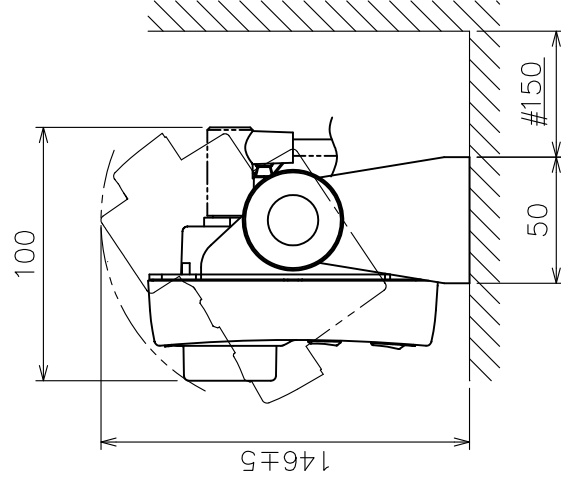

注 記

- 1) 指定外の寸法公差は表1による。
- 2) #印寸法は最小サービス空間寸法とする。
- 3) 取付用ネジはトラスタツピンネジ呼び径4×16を使用のこと。

NOTE

1. TABLE 1 INDICATES TOLERANCE OF DIMENSIONS WHICH IS NOT SPECIFIED.
2. #: MINIMUM SERVICE CLEARANCE.
3. USE TAPPING SCREWS φ4x16 FOR FIXING THE UNIT.

DRAWN	9/Nov/09	T. YAMASAKI	TITLE	FAP-7001
CHECKED	9/Nov/09	T. TAKENO	名称	操作部 (卓上装備)
APPROVED	24/Nov/09	R. Esumi	外寸図	
SCALE	1/100	質量はケーブルを含まず。 kg	NAME	CONTROL UNIT (TABLETOP MOUNT)
DWG.No.	C7272-G03-A	REF.No.	64-028-120G-3	OUTLINE DRAWING

表1 TABLE 1

寸法区分 (mm) DIMENSION	公差 (mm) TOLERANCE
L ≤ 50	±1.5
50 < L ≤ 100	±2.5
100 < L ≤ 500	±3

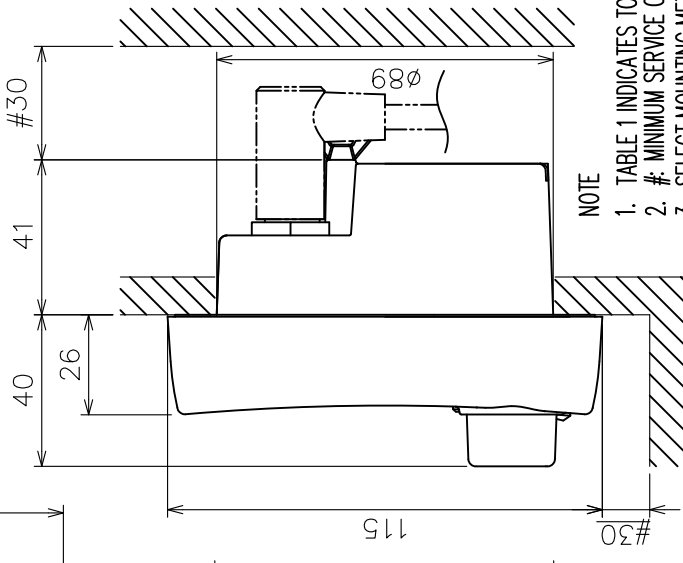
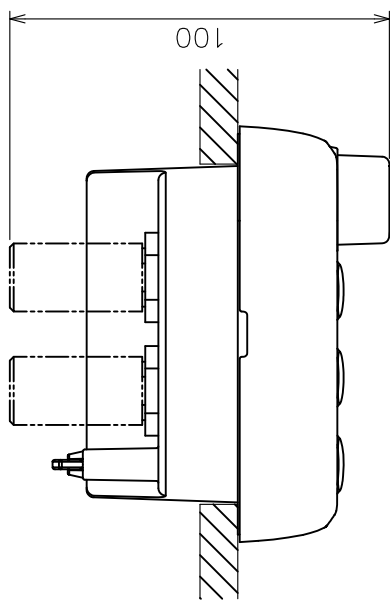
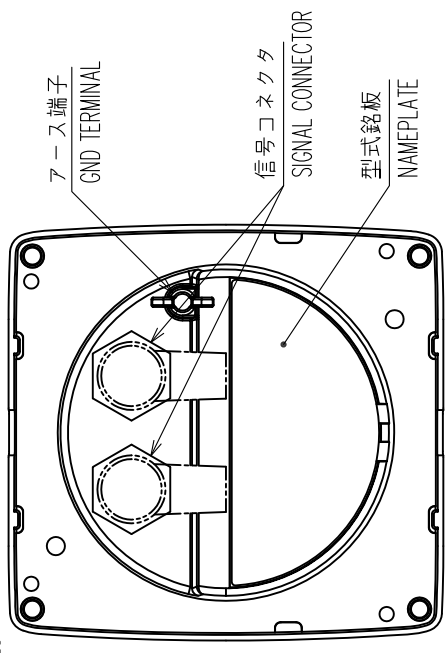
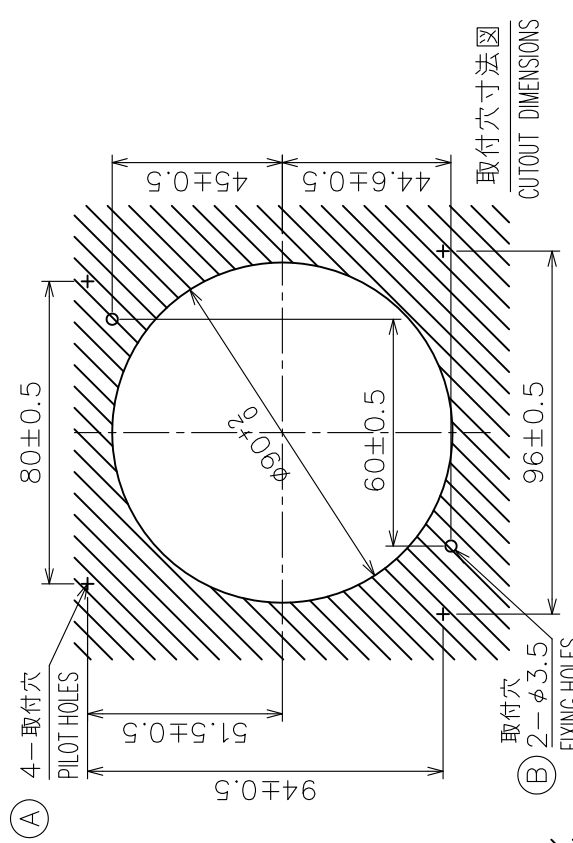

NOTE

- TABLE 1 INDICATES TOLERANCE OF DIMENSIONS WHICH IS NOT SPECIFIED.
- # MINIMUM SERVICE CLEARANCE.
- SELECT MOUNTING METHOD;

- (A) : USE TAPPING SCREWS  $\phi 3 \times 20$ .
- (B) : USE M3x50 STUD AND M3 P.W./S.W./WING NUT.

注記

- 指定外の寸法公差は表1による。
- #印寸法は最小サービスクリアランスとする。
- 取付方法は次の2種類から選択
  - (A) : ナベタッピンネジ呼び径3×20を使用のこと。
  - (B) : M3×50寸切ボルト、M3平座金・バネ座金・蝶ナットを使用のこと。

DRAWN	9/Nov/09	I.YAMASAKI	TITLE	FAP-7011
CHECKED	9/Nov/09	I.TAKENO	名称	操作部 (サーフェスマウント)
APPROVED	24/Nov/09	R. Esumi	外寸図	
SCALE	1/100	質量はケーブルを含まず。 MASS 0.34 kg	NAME	CONTROL UNIT (SURFACE MOUNT)
DWG.No.	C7273-G01-A	REF.No.	64-028-300G-2	OUTLINE DRAWING





表1 TABLE 1

寸法区分 (mm) DIMENSION	公差 (mm) TOLERANCE
L ≤ 50	±1.5
50 < L ≤ 100	±2.5
100 < L ≤ 500	±3

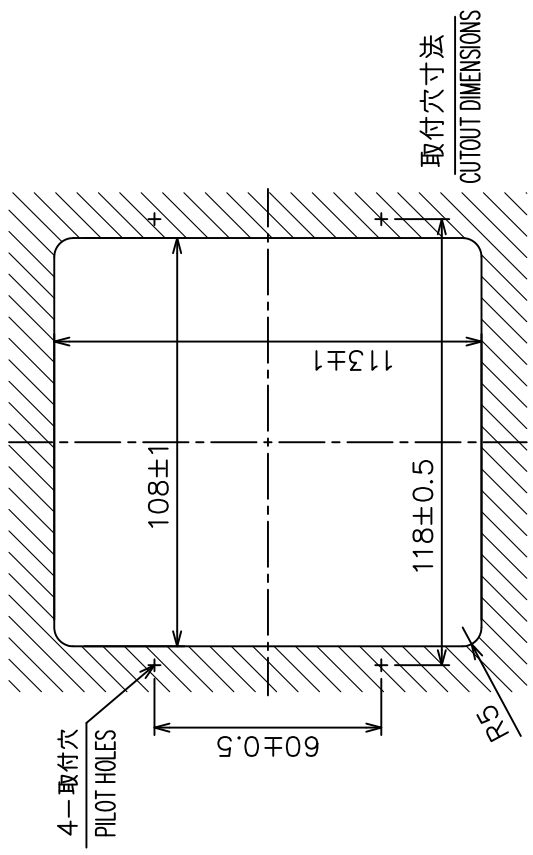
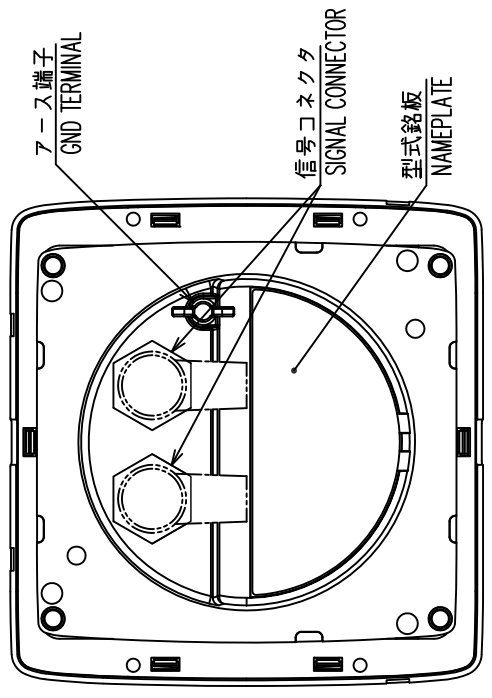
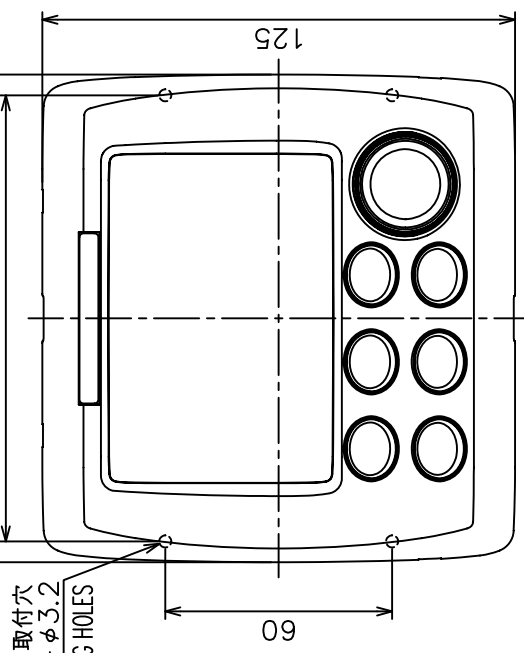
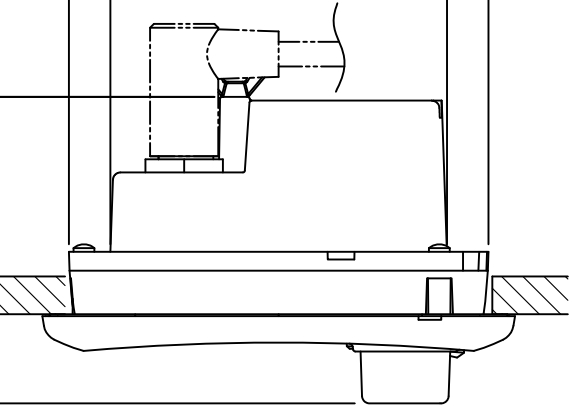
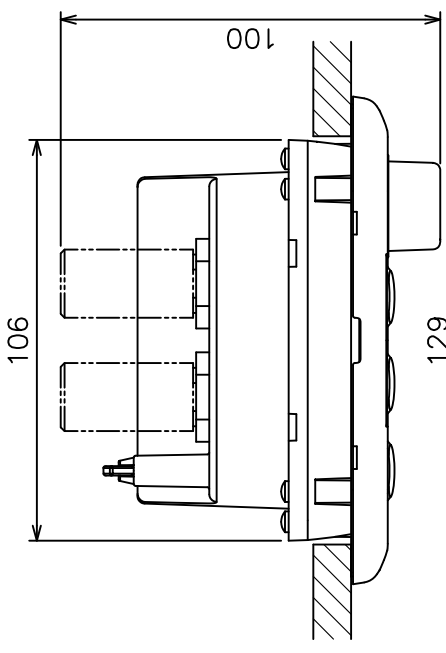

取付穴  
4-φ3.2  
FIXING HOLES

- 注記 1) 指定外の寸法公差は表1による。  
 2) #印寸法は最小サービス空間寸法とする。  
 3) 取付用ネジはナベタップピンネジ呼び径3×20を使用のこと。
- NOTE 1. TABLE 1 INDICATES TOLERANCE OF DIMENSIONS WHICH IS NOT SPECIFIED.  
 2. # MINIMUM SERVICE CLEARANCE.  
 3. USE TAPPING SCREWS φ3x20 FOR FIXING THE UNIT.

DRAWN	9/Nov/09	I.YAMASAKI	TITLE	FAP-7011
CHECKED	9/Nov/09	I.TAKENO	名称	操作部 (7 フラッシュマウント)
APPROVED	24/Nov/09	R. Esumi	外寸図	
SCALE	#100 質量はケーブルを含みず。 MASS 0.35 kg			
DWG.No.	C7273-G02-A	REF.No.	64-028-310G-2	OUTLINE DRAWING



表1 TABLE 1

寸法区分 (mm) DIMENSION	公差 (mm) TOLERANCE
L ≤ 50	±1.5
50 < L ≤ 100	±2.5
100 < L ≤ 500	±3

- 注記 1) 指定外の寸法公差は表1による。  
 2) #印寸法は最小サービスクリアランスとする。  
 3) 取付用ネジはトラスタックピンネジ呼び径4×16を使用のこと。
- NOTE 1. TABLE 1 INDICATES TOLERANCE OF DIMENSIONS WHICH IS NOT SPECIFIED.  
 2. # MINIMUM SERVICE CLEARANCE.  
 3. USE TAPPING SCREWS φ4×16 FOR FIXING THE UNIT.

DRAWN	9/Nov/09	T. YAMASAKI	TITLE	FAP-7011
CHECKED	9/Nov/09	I. TAKENO	名称	操作部 (卓上装備)
APPROVED	24/Nov/09	R. Esumi	外寸図	
SCALE		100% 質量はケーブルを含まず。 # MASS 0.52 kg	NAME	CONTROL UNIT (TABLETOP MOUNT)
DWG.No.	C7273-G03-A	REF.No.	64-028-320G-2	OUTLINE DRAWING

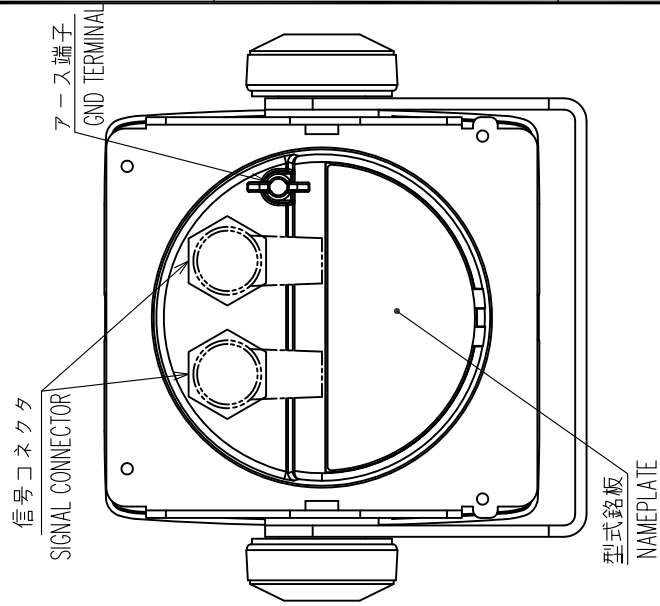
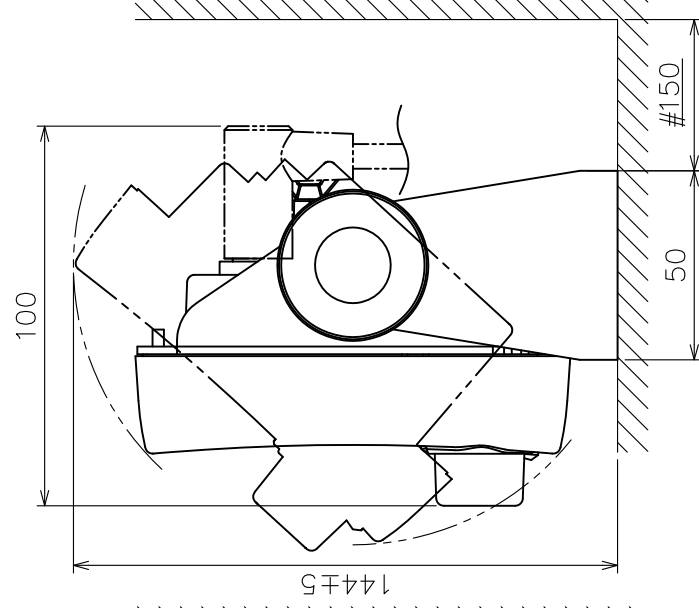
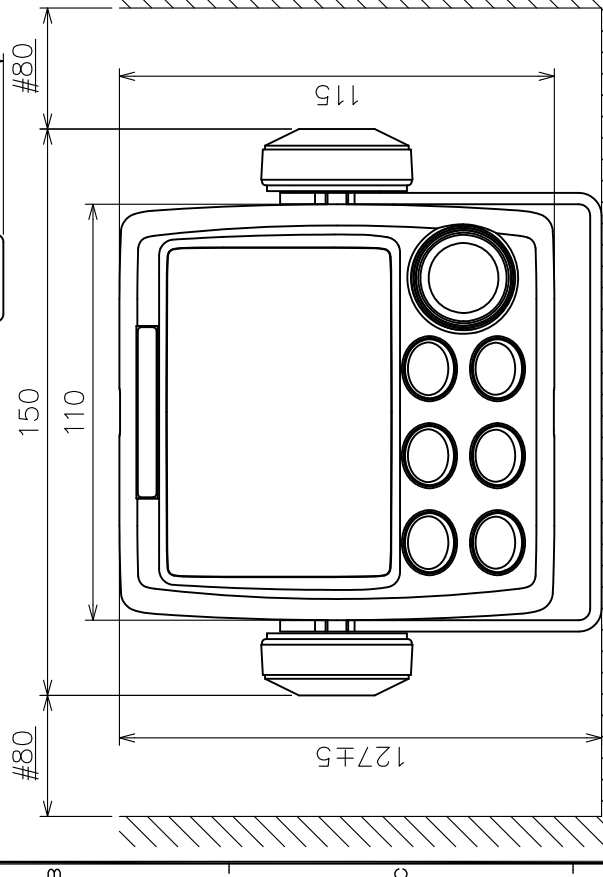
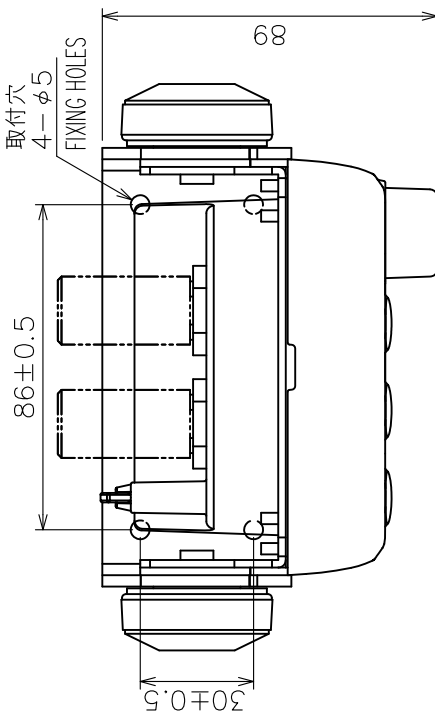

表1 TABLE 1

寸法区分 (mm) DIMENSION	公差 (mm) TOLERANCE
L ≤ 50	±1.5
50 < L ≤ 100	±2.5
100 < L ≤ 500	±3

取付穴寸法図 (壁厚10mmまで)  
CUTOUT DIMENSIONS (BULKHEAD: 10 OR LESS)  
(30)

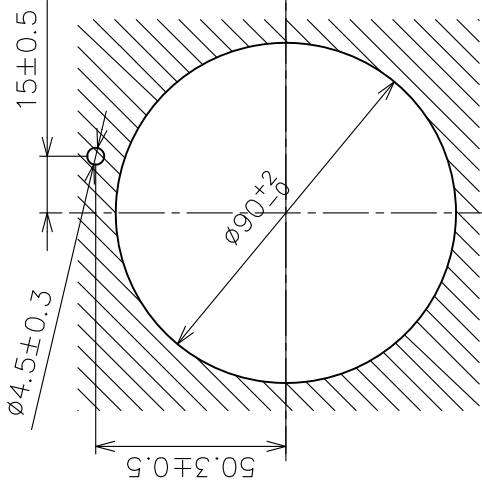

図1 Fig. 1



- 注記 1) 指定外の寸法公差は表1による。  
2) 壁厚10~20の場合の取付方法は図1による。  
(スピンナット向きを逆にして取付ける)
- NOTE 1. TABLE 1 INDICATES TOLERANCE OF DIMENSIONS WHICH IS NOT SPECIFIED.  
2. FIG. 1 INDICATES THE METHOD OF FIXING TO A BULKHEAD THICKNESS 10 TO 20.  
(REVERSE THE SPIN-NUT TO SCREW THE UNIT)

DRAWN	4/Oct/2013	I. YAMASAKI	TITLE	FAP-7011C
CHECKED	4/Oct/2013	H. MAKI	名称	操作部
APPROVED	4/Oct/2013	H. MAKI	NAVPilot-71C	外寸図
SCALE	1/2	質量はケーブルを含みません。 MASS DOES NOT INCLUDE CABLE.	NAME	CONTROL UNIT
DMC No.	C7278-G01-B	REF. No.	64-032-100G-3	OUTLINE DRAWING

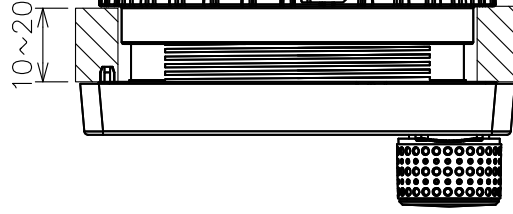
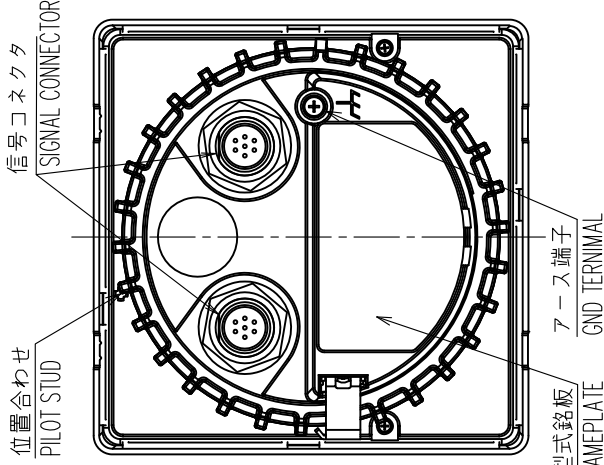
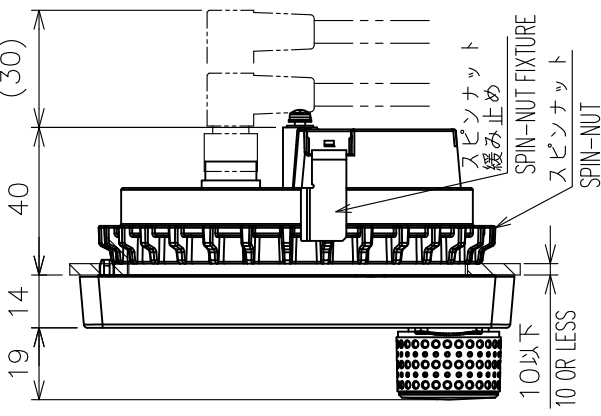
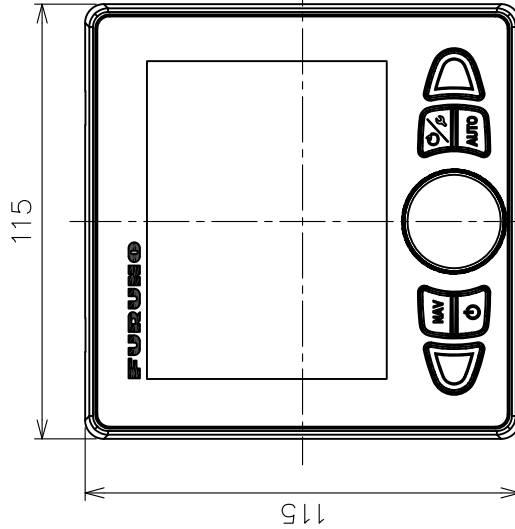
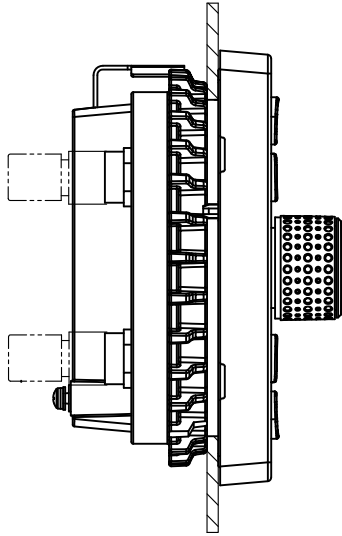
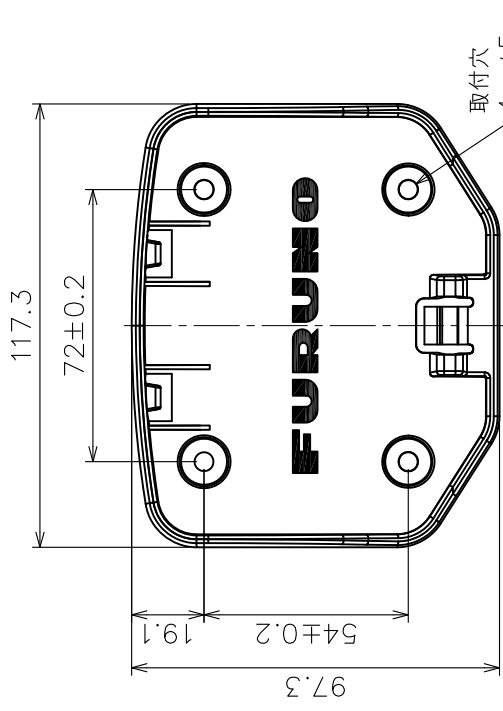
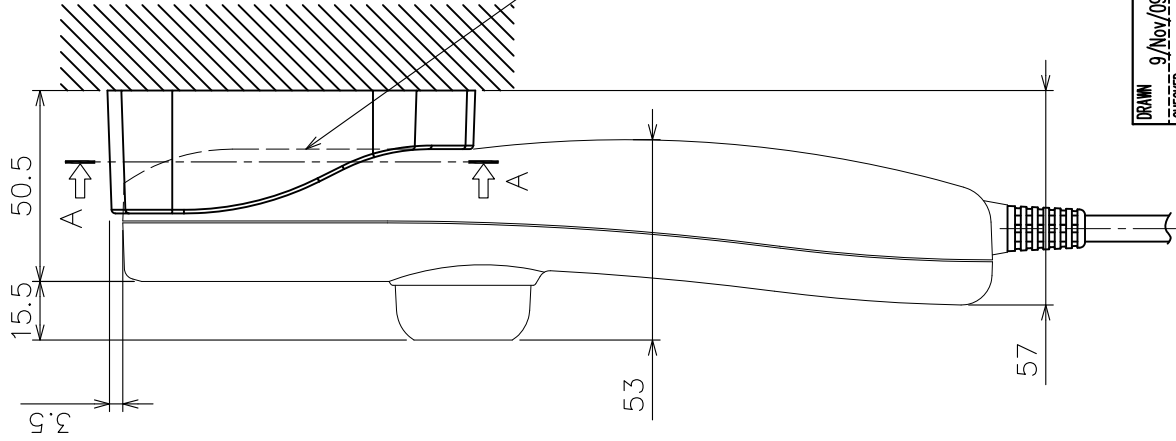
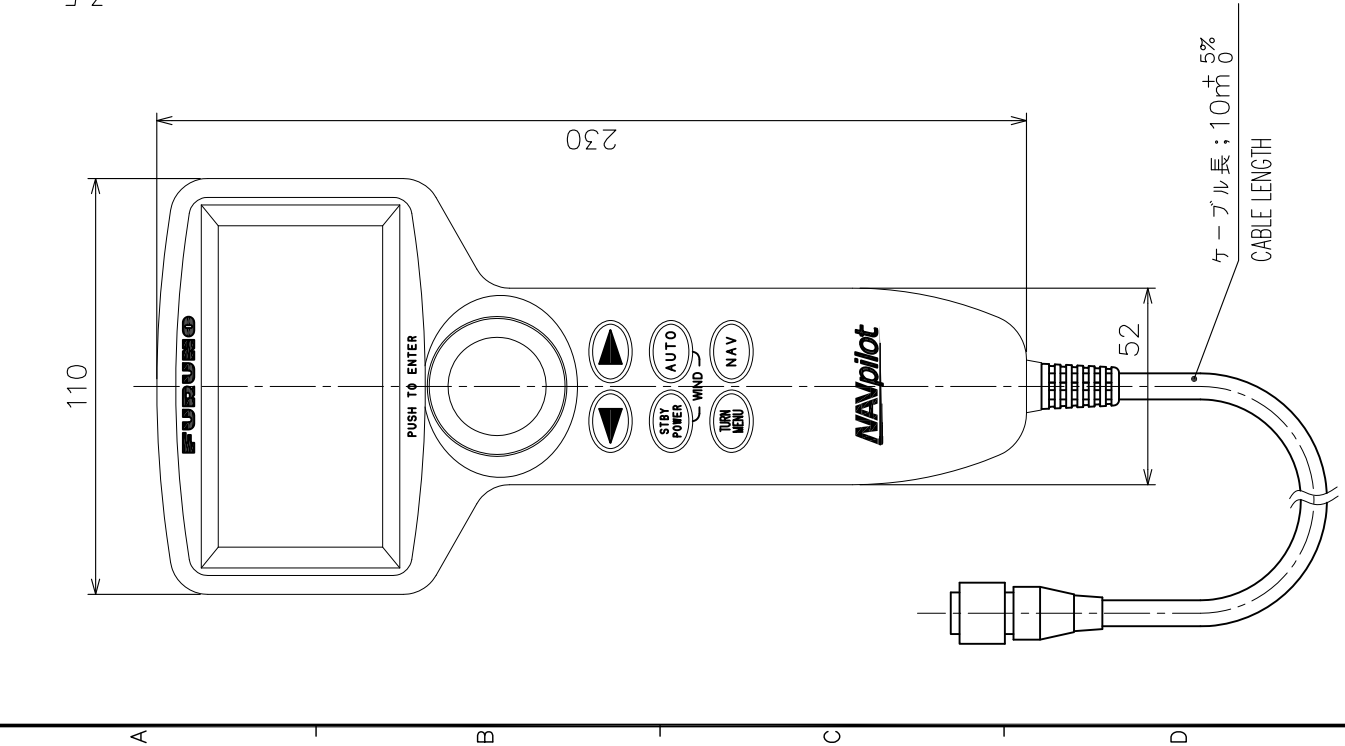

取付寸法図 (矢視A)  
MOUNTING DIMENSIONS (VIEW A)

表1 TABLE 1

寸法区分 (mm) DIMENSION	公差 (mm) TOLERANCE
$L \leq 50$	$\pm 1.5$
$50 < L \leq 100$	$\pm 2.5$
$100 < L \leq 500$	$\pm 3$

注 記

- 1) 指定外の寸法公差は表1による。
- 2) 取付用ネジはトラスタツピンネジ呼び径4×20を使用のこと。

NOTE

1. TABLE 1 INDICATES TOLERANCE OF DIMENSIONS WHICH IS NOT SPECIFIED.
2. USE TAPPING SCREWS  $\phi 4 \times 20$  FOR FIXING THE UNIT.

DRAWN	9/Nov/09	I.YAMASAKI	TITLE	FAP-7021
CHECKED	9/Nov/09	I.TAKENO	名称	操作部
APPROVED	24/Nov/09	R. Esumi	NAME	外寸図
SCALE	MASS 0.99 kg	±10%質量はケーブルを含む。	NAME	CONTROL UNIT
DMC.No.	C7274-G01-A	REF.No.	64-028-400G-1	OUTLINE DRAWING

表1 TABLE 1

寸法区分 (mm) DIMENSION	公差 (mm) TOLERANCE
$L \leq 50$	$\pm 1.5$
$50 < L \leq 100$	$\pm 2.5$
$100 < L \leq 500$	$\pm 3$

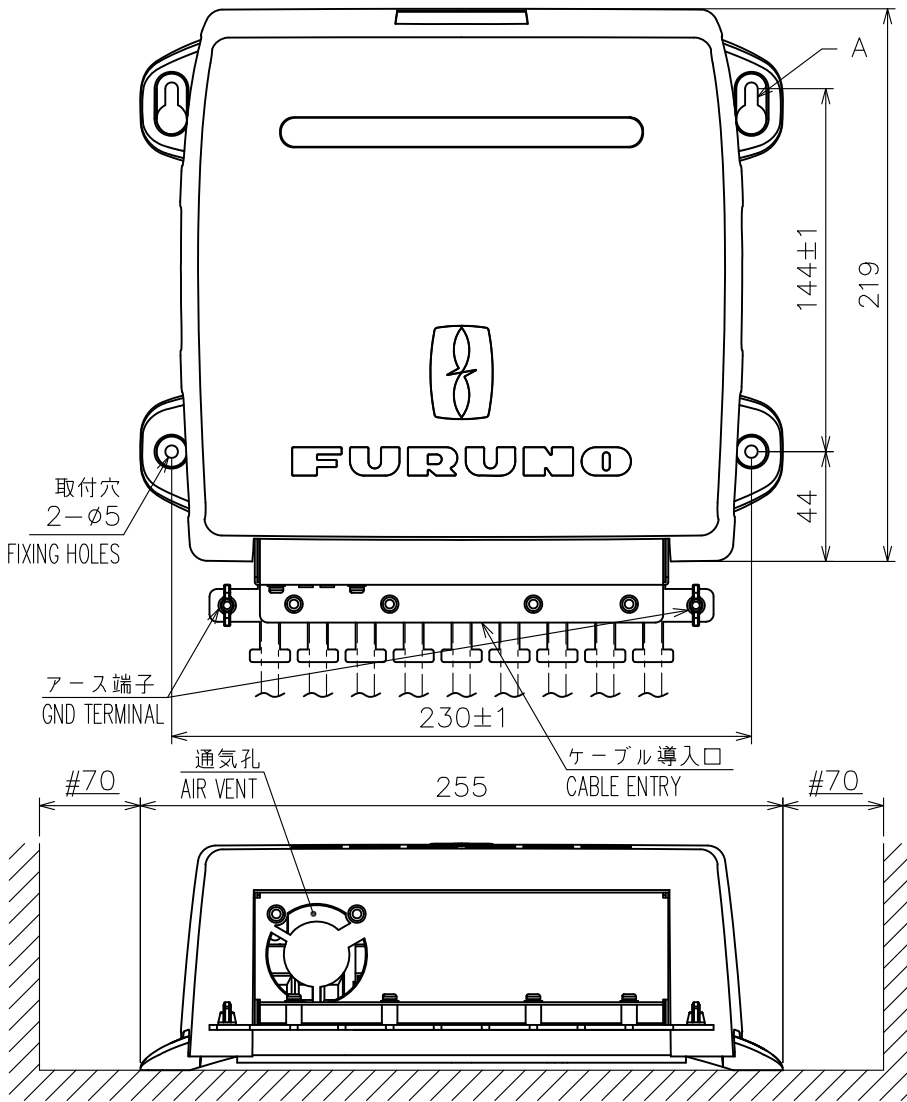
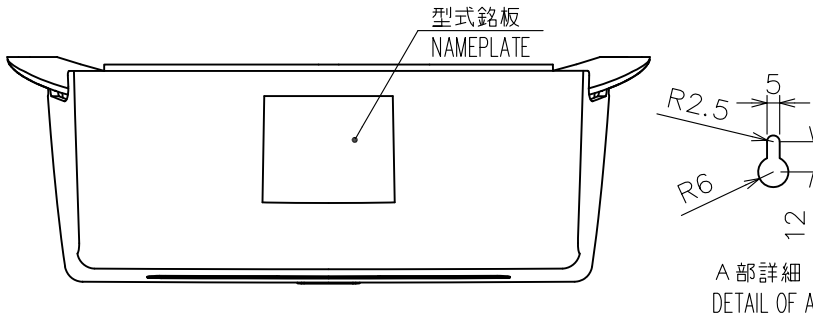

- 注 記 1) 指定外の寸法公差は表1による。  
 2) #印寸法は最小サービス空間寸法とする。  
 3) 取付用ネジはトラスタップピンネジ呼び径4×20を使用のこと。

- NOTE 1. TABLE 1 INDICATES TOLERANCE OF DIMENSIONS WHICH IS NOT SPECIFIED.  
 2. #: MINIMUM SERVICE CLEARANCE.  
 3. USE TAPPING SCREWS  $\phi 4 \times 20$  FOR FIXING THE UNIT.

DRAWN	9/Nov/09 T.YAMASAKI	TITLE	FAP-7002
CHECKED	9/Nov/09 T.TAKENO	名称	制御部 (壁掛装備)
APPROVED	24/Nov/09 R.Esumi		外寸図
SCALE	MASS 1.9 ±10% kg	NAME	PROCESSOR UNIT (BULKHEAD MOUNT)
DWG.No.	C7272-G04-A	REF.No.	64-028-200G-1
			OUTLINE DRAWING

表 1 TABLE 1

寸法区分 (mm) DIMENSIONS	公差 (mm) TOLERANCE
$L \leq 50$	$\pm 1.5$
$50 < L \leq 100$	$\pm 2.5$
$100 < L \leq 500$	$\pm 3$
$500 < L \leq 1000$	$\pm 4$

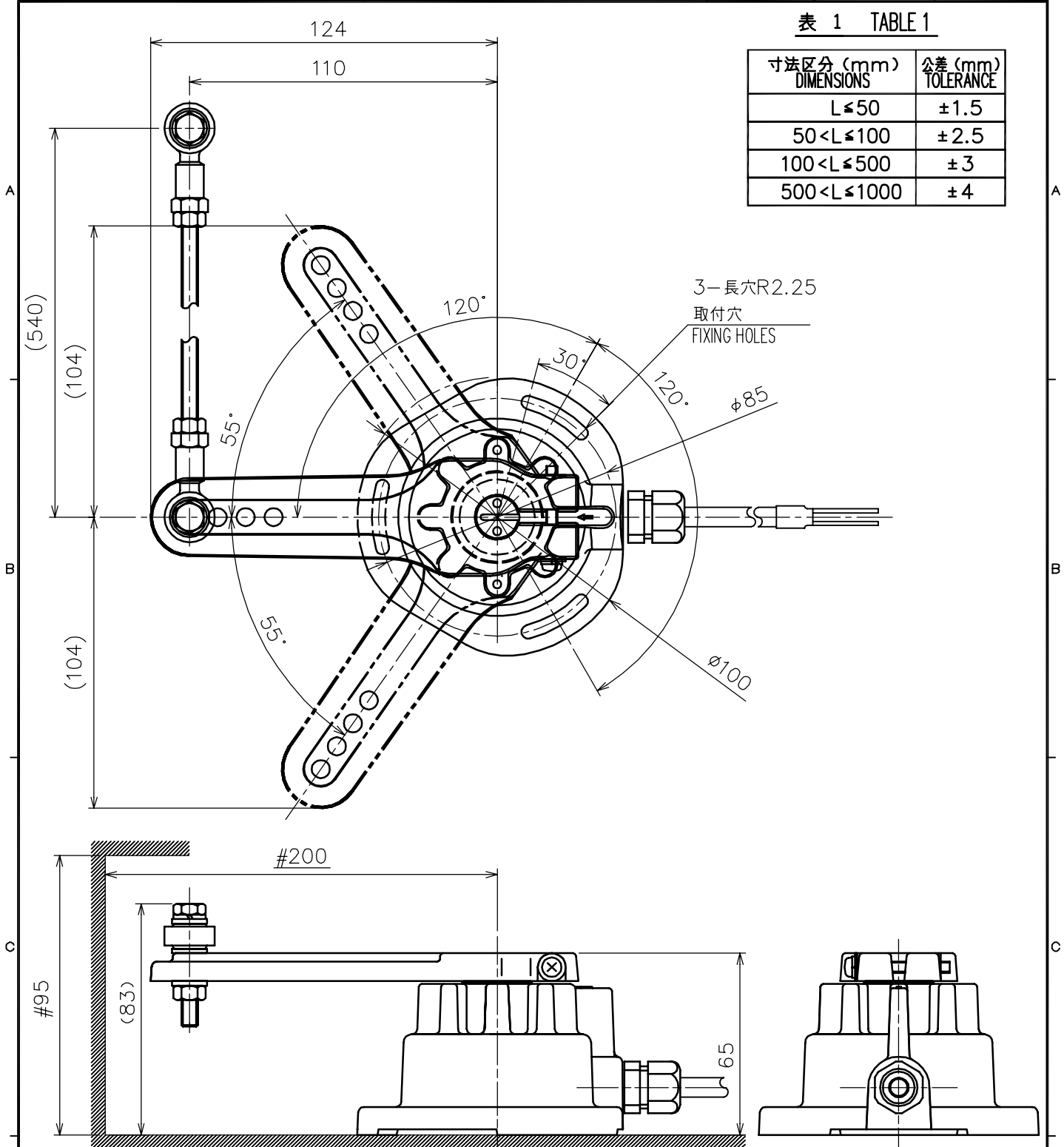

- 注 記 1) #印寸法は最小サービス空周寸法とする。  
 2) 指定外の寸法公差は表1による。  
 3) 取付用ネジは+トラスタップインネジ呼び径4×20を使用のこと。

- NOTE 1. #: MINIMUM SERVICE CLEARANCE.  
 2. TABLE 1 INDICATES TOLERANCE OF DIMENSIONS WHICH IS NOT SPECIFIED.  
 3. USE SELF-TAPPING SCREWS 4x20 FOR FIXING THE UNIT.

DRAWN Jan. 19, '06	E. MIYOSHI	TITLE FAP-6112
CHECKED	TAKAHASHI. T	名称 追従発信器
APPROVED	Y. Hatai	外寸図
SCALE	MASS ±10% 0.46 kg	NAME RUDDER REFERENCE UNIT
DWG.No.	C7250-G07-A	REF.No. 64-024-460G-0
		OUTLINE DRAWING

表1 TABLE 1

寸法区分 (mm) DIMENSIONS	公差 (mm) TOLERANCE
L ≤ 50	±1.5
50 < L ≤ 100	±2.5
100 < L ≤ 500	±3
500 < L ≤ 1000	±4

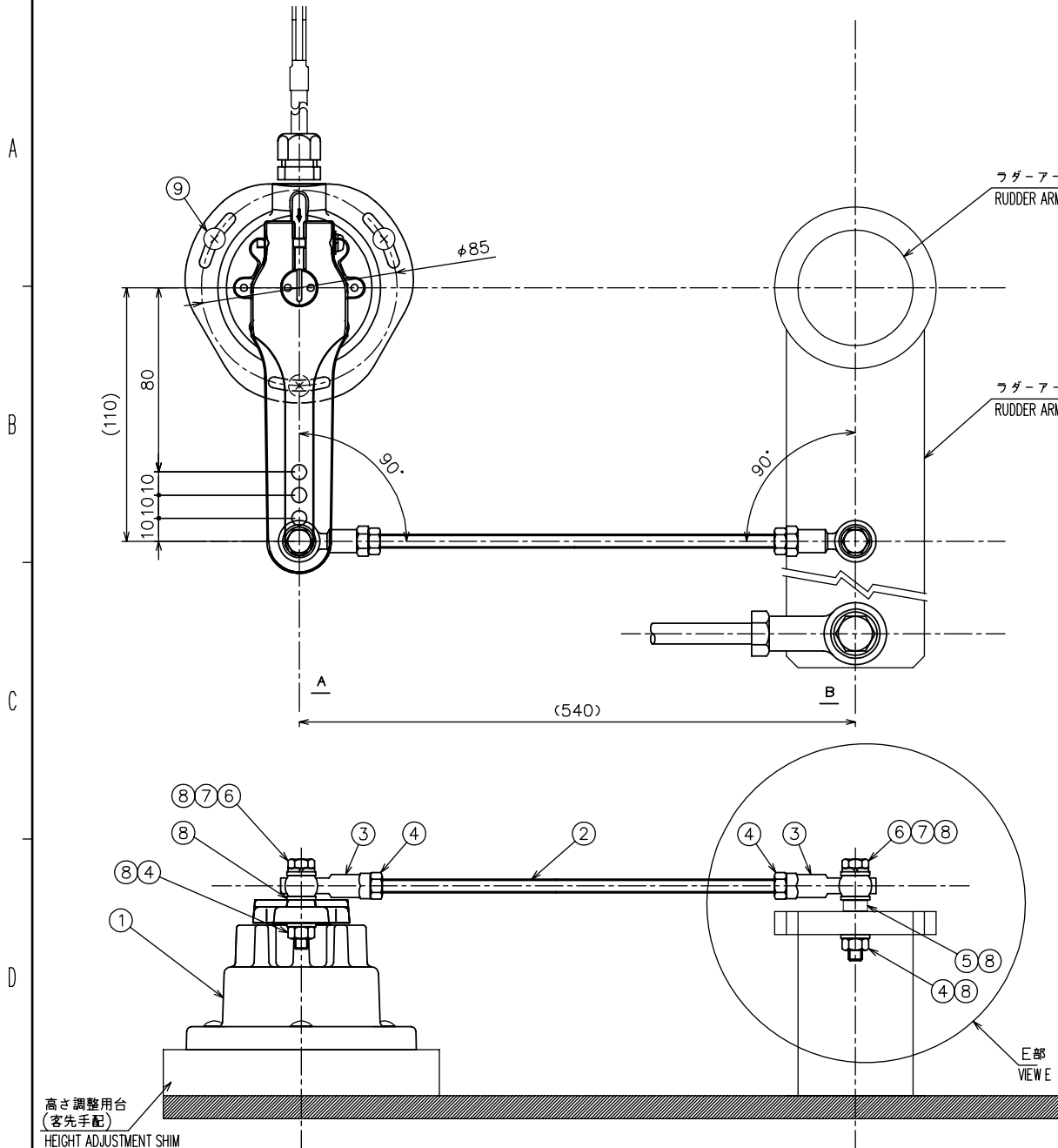

注記 1) A 日の軸線は平行のこと  
2) ラダーアーム上面とレンケツボウは平行になるようにFAP-6112本体の高さを調整すること。

NOTE 1. AB AXIS SHOULD BE PARALLEL.  
2. ADJUST HEIGHT OF FAP-6112 SO UPPER SURFACE OF RUDDER ARM IS PARALLEL WITH JOINT ROD.

9	トラスタップピンネジ SELF-TAPPING SCREWS	SUS304	3		4x20 (工事材料) 4x20 (INSTALLATION MATERIALS)
8	平座金 FLAT WASHER	SUS304	6		M6 (工事材料) M6 (INSTALLATION MATERIALS)
7	バネ座金 SPRING WASHER	SUS304	2		M6 (工事材料) M6 (INSTALLATION MATERIALS)
6	六角ボルト HEX. BOLT	SUS304	2		M6x40 (工事材料) M6x40 (INSTALLATION MATERIALS)
5	カサアゲスペース SPACER	SUS304	1	64-024-4612	工事材料 INSTALLATION MATERIALS
4	六角ナット HEX. NUT	SUS304	4		M6 (工事材料) M6 (INSTALLATION MATERIALS)
3	ロッドエンドベアリング ROD END BEARING	SUS303	2	RBT6	工事材料 INSTALLATION MATERIALS
2	連結棒 JOINT ROD	SUS304	1	64-024-4606	工事材料 INSTALLATION MATERIALS
1	追従発信器本体 RUDDER REFERENCE UNIT		1	FAP-6112	
品番 ITEM	品名 NAME	材質 MATERIAL	数量 QTY	図番 DWG.NO.	摘要 REMARKS

DRAWN	Jun. 19, '06	E. MIYOSHI	TITLE	FAP-6112
CHECKED		TAKAHASHI, T	名称	追従発信器
APPROVED		Y. Hatai		装備図
SCALE	MASS ±10%	0.46 kg	質量は工事材料・ケーブルを含まず。 MASS DOES NOT INCLUDE INSTALLATION MATERIALS OR CABLE.	NAME
DWG No.	C7250-Y01-A	REF No.	64-024-461G-0	RUDDER REFERENCE UNIT INSTALLATION PROCEDURE

表 1 TABLE 1

寸法区分 (mm) DIMENSION	公差 (mm) TOLERANCE
$L \leq 50$	$\pm 1.5$
$50 < L \leq 100$	$\pm 2.5$
$100 < L \leq 500$	$\pm 3$

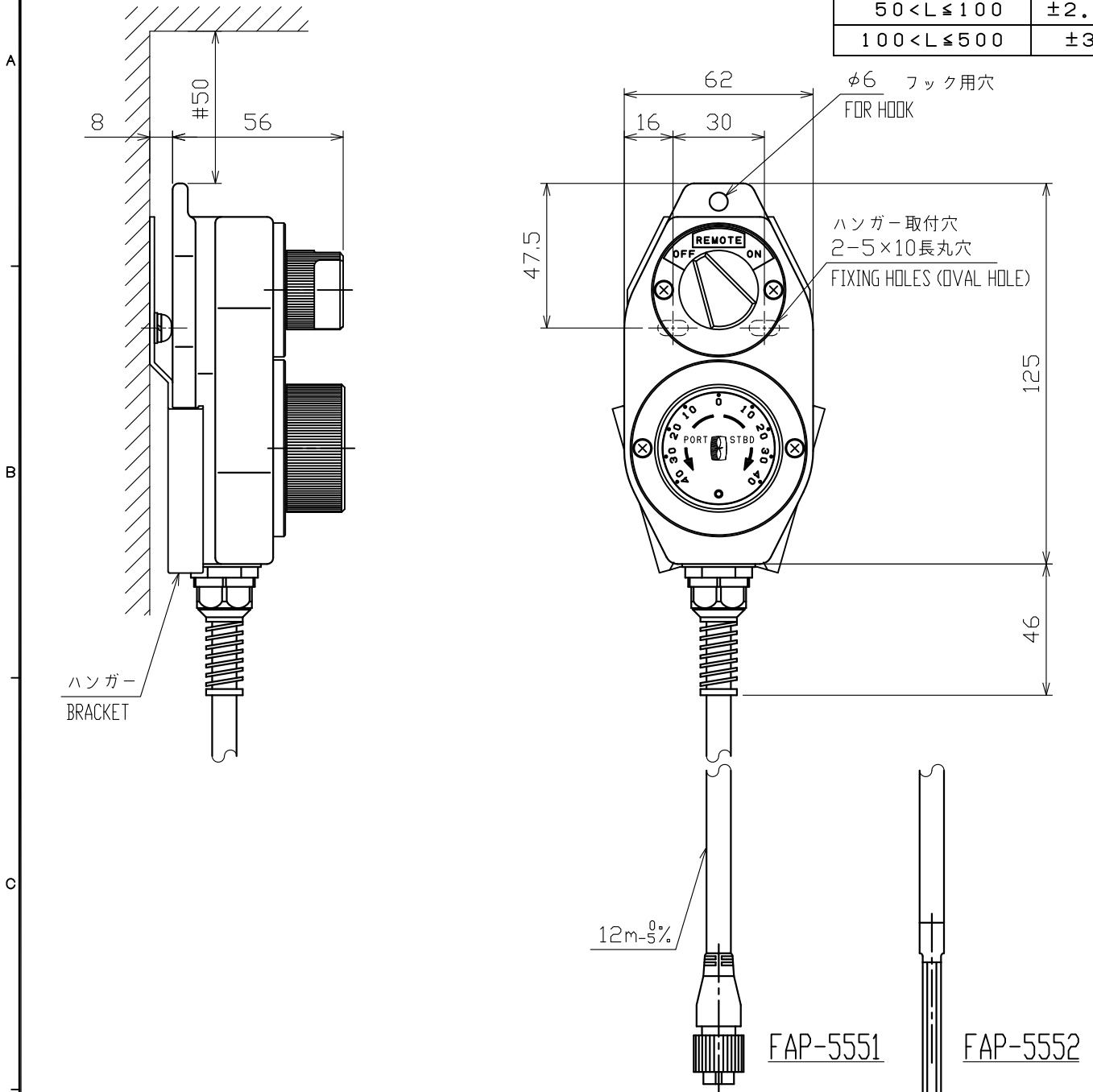

- 注 記 1) 指定外の寸法公差は表 1 による。  
 2) #印寸法は最小サービス空間寸法とする。  
 3) 取付用ネジは+マルモクネジ呼び径 4.8×20 を使用のこと。

- NOTE 1. TABLE 1 INDICATES TOLERANCE OF DIMENSIONS WHICH IS NOT SPECIFIED.  
 2. #: RECOMMENDED SERVICE CLEARANCE.  
 3. USE WOOD SCREWS  $\phi 4.8 \times 20$  FOR FIXING THE UNIT.

DRAWN	1/Nov/2011 T.YAMASAKI	TITLE	FAP-5551/5552
CHECKED	1/Nov/2011 H.MAKI	名称	遠隔管制器 (ダイヤル式)
APPROVED	1/Nov/2011 Y.NISHIYAMA		外寸図
SCALE	MASS $0.5 \pm 10\%$ kg	質量はケーブルを含まず。 MASS DOES NOT INCLUDE CABLE.	NAME
DWG.No.	C7235-G04-C	64-015-230G-2	REMOTE CONTROLLER (DIAL TYPE) OUTLINE DRAWING



寸法区分 (mm) DIMENSION	公差 (mm) TOLERANCE
$L \leq 50$	$\pm 1.5$
$50 < L \leq 100$	$\pm 2.5$
$100 < L \leq 500$	$\pm 3$

表 1 TABLE 1

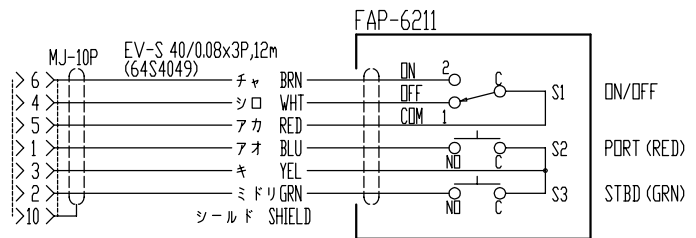
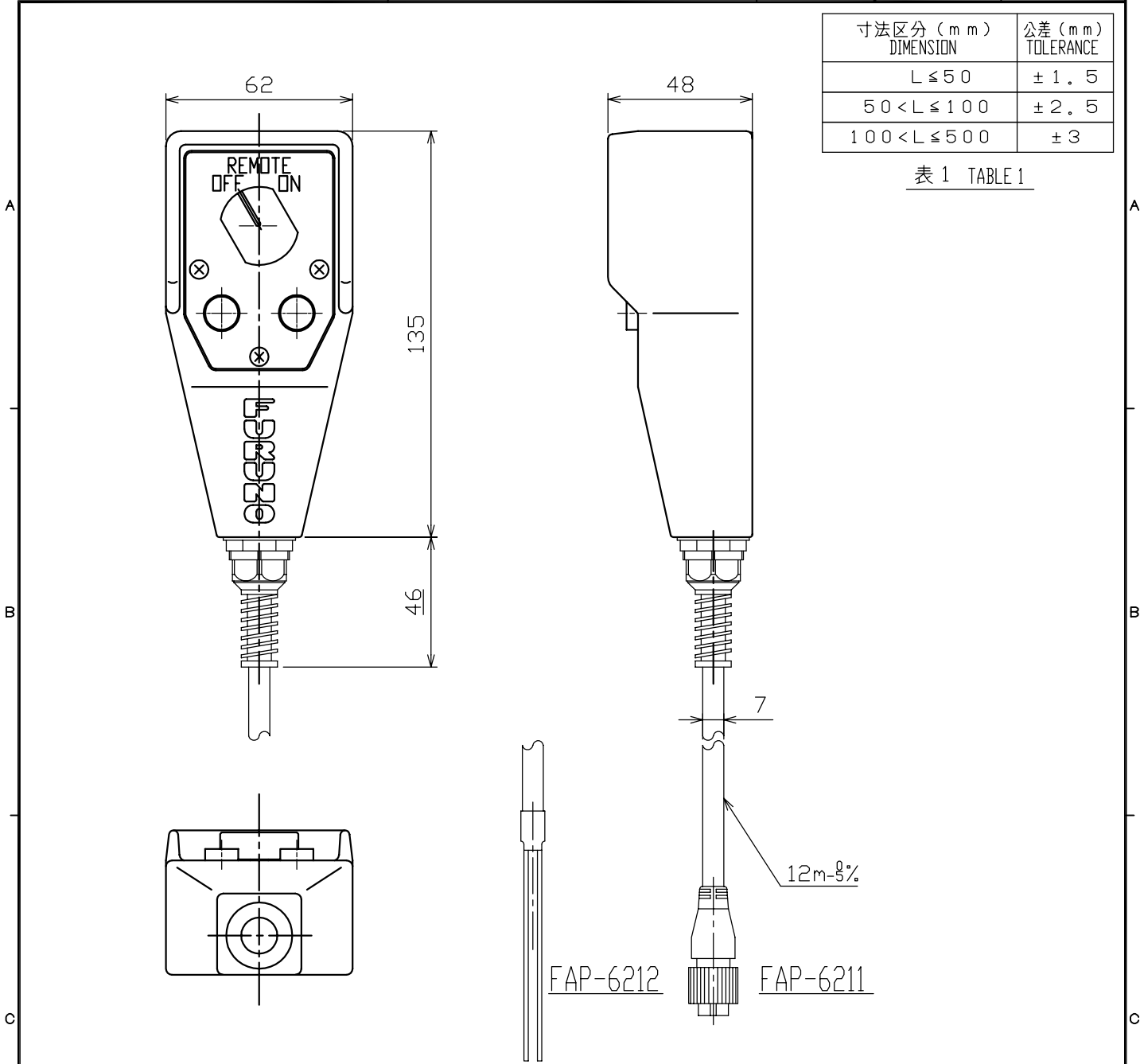

注 記 1) 指定外の寸法公差は表 1 による。

NOTE 1. TABLE 1 INDICATES TOLERANCE OF DIMENSION.

DRAWN Jun. 2 '03 T.YAMASAKI	TITLE FAP-6211/6212
CHECKED Jun. 2 '03 T.Matsuguchi	名称 遠隔管制器 (ボタン式)
APPROVED	外寸図
SCALE MASS 0.5 ±10% kg 質量はケーブルを含まず。 MASS W/O CABLE.	NAME REMOTE CONTROLLER (BUTTON TYPE)
DWG.No. C7235-G05-B	64-015-350G-1 OUTLINE DRAWING

寸法区分 (mm) DIMENSION	公差 (mm) TOLERANCE
$L \leq 50$	$\pm 1.5$
$50 < L \leq 100$	$\pm 2.5$
$100 < L \leq 500$	$\pm 3$

表 1 TABLE 1

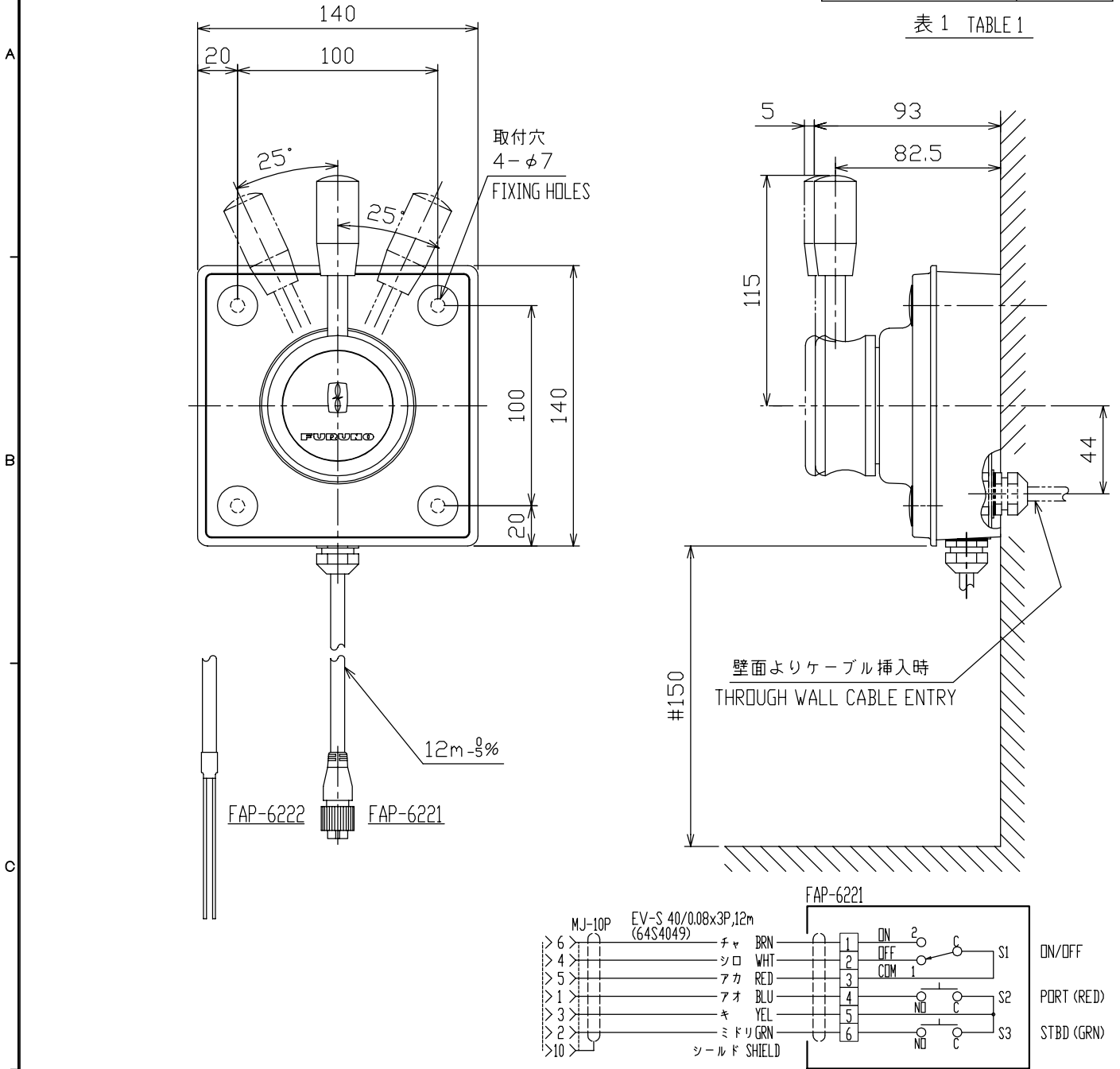

- 注 記 1) #印寸法は最小サービス空間寸法とする。  
 2) 指定外の寸法公差は表 1 による。  
 3) 取付用ネジは M6×50 ロックボルトを使用のこと。

- NOTE 1. #: RECOMMENDED SERVICE CLEARANCE.  
 2. TABLE 1 INDICATES TOLERANCE OF DIMENSIONS.  
 3. USE M6x50 BOLTS FOR FIXING THE UNIT.

DRAWN Jun. 2 '03 T.YAMASAKI	TITLE FAP-6221/6222
CHECKED Jun. 2 '03 T.Matsuguchi	名称 遠隔管制器 (レバー式)
APPROVED	外寸図
SCALE MASS 1.8 ±10% kg 質量はケーブルを含みます。 MASS W/O CABLE.	NAME REMOTE CONTROLLER (LEVER TYPE)
DWG.No. C7235-G06-B	64-015-400G-1 OUTLINE DRAWING

寸法区分 (mm) DIMENSION	公差 (mm) TOLERANCE
$L \leq 50$	$\pm 1.5$
$50 < L \leq 100$	$\pm 2.5$
$100 < L \leq 500$	$\pm 3$

表 1 TABLE 1

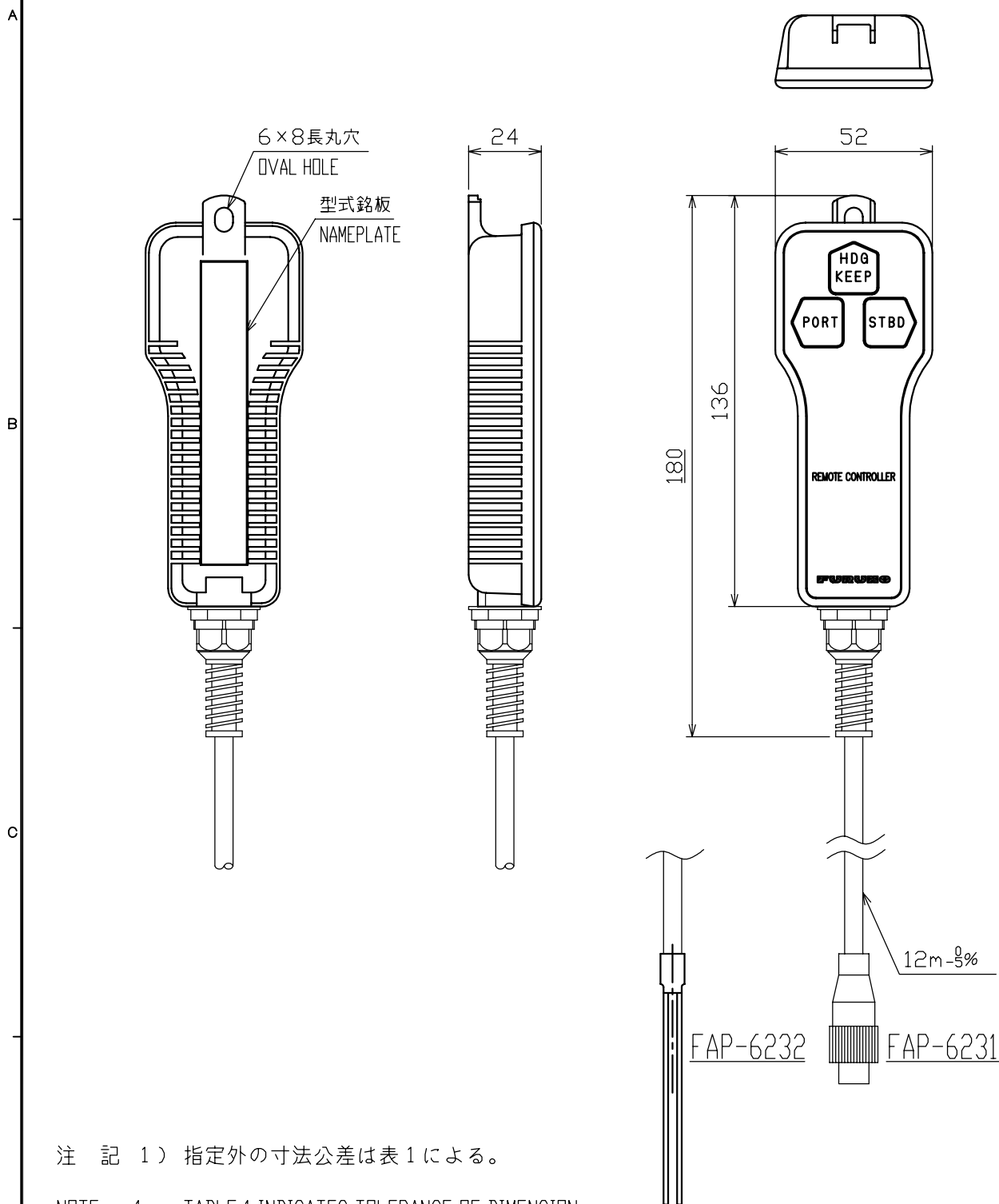

注 記 1) 指定外の寸法公差は表 1 による。

NOTE 1. TABLE 1 INDICATES TOLERANCE OF DIMENSION.

DRAWN Jun. 2 '03 T.YAMASAKI	TITLE FAP-6231/6232
CHECKED Jun. 2 '03 T.Matsuguchi	名称 遠隔管制器 (ドッジリモコン)
APPROVED Jun. 04 '03 Matsuguchi	外寸図
SCALE MASS 0.1 $\pm 10\%$ kg 質量はケーブルを含まず。 MASS W/O CABLE.	NAME REMOTE CONTROLLER (DODGE TYPE)
DWG.No. C7237-G06-B	64-019-400G-1 OUTLINE DRAWING

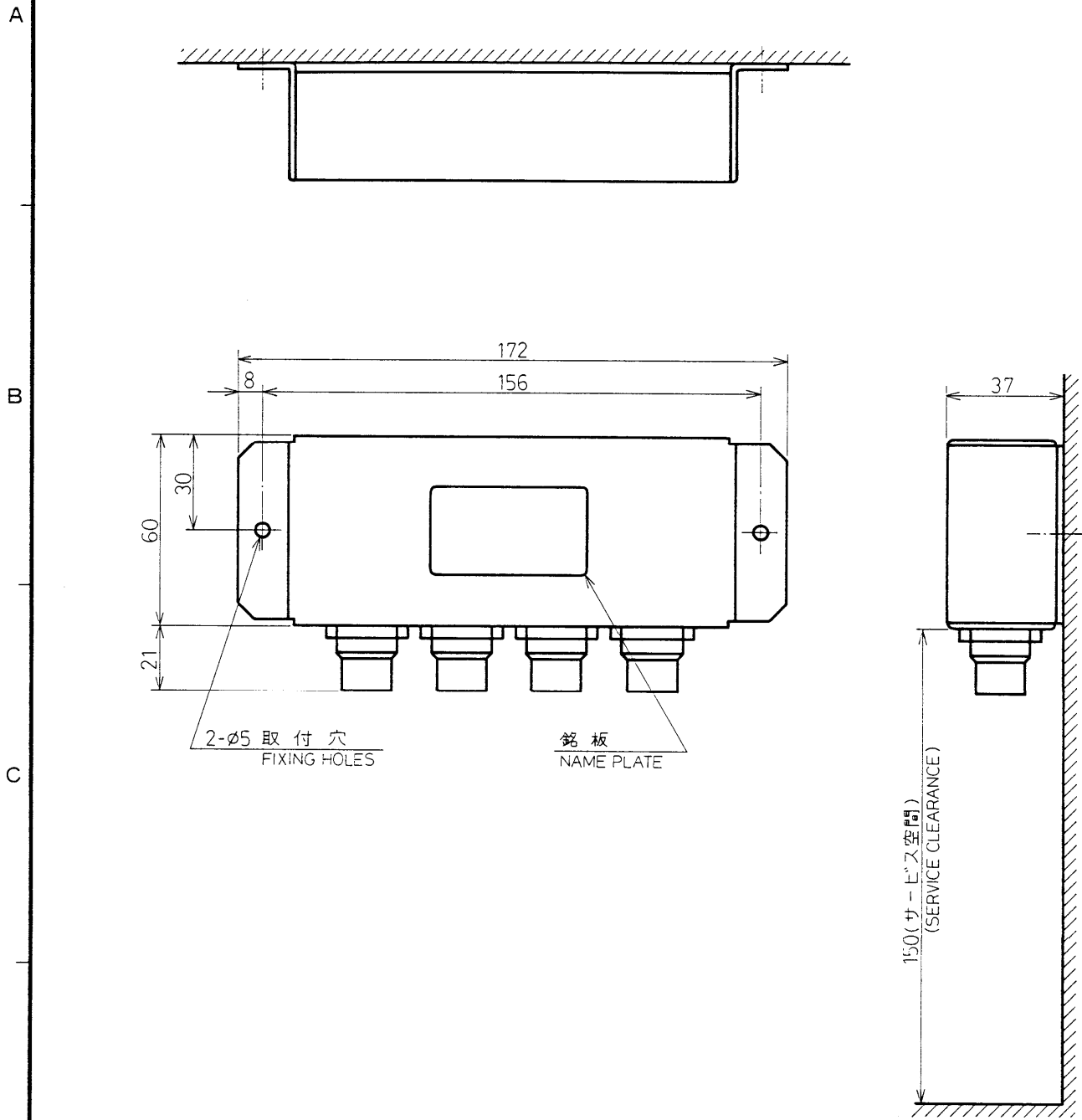

FAP-330

承認 APPROVED	品番 ITEM	品名 NAME	材質 MATERIAL	数量 Q'TY	図番 DWG. NO.	摘要 REMARKS
JUN. 3. '92 T. YAKKIO		三角法 THIRD ANGLE PROJECTION				名称 TITLE リモコン分配器
検 CHECKED	JUN. 2. '92 N. SAITO	尺 SCALE				FAP-6800 DISTRIBUTOR
製 DRAWN	JUN. 2. '92 S. N. S. L.	重 WEIGHT	0.3 kg		図番 DWG. NO.	C7235-G03-A

表1 TABLE 1

寸法区分 (mm) DIMENSION	公差 (mm) TOLERANCE
L ≤ 50	±1.5
50 < L ≤ 100	±2.5
100 < L ≤ 500	±3

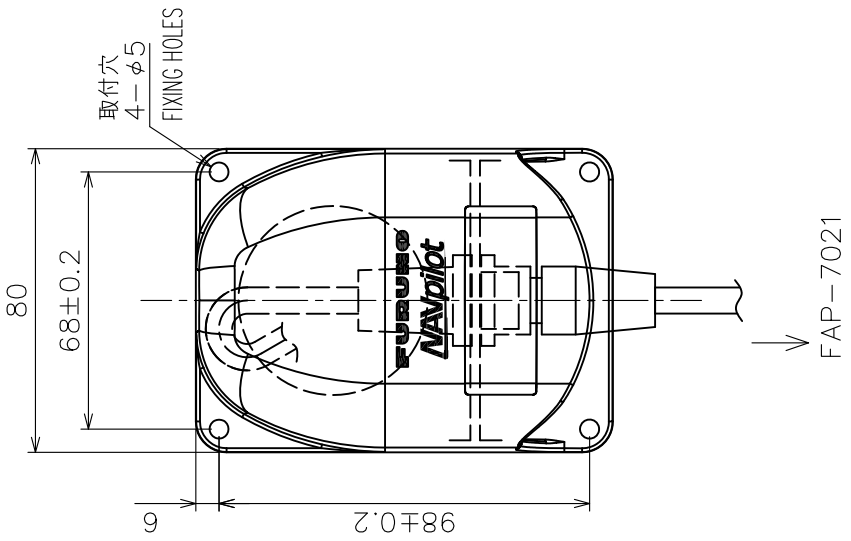
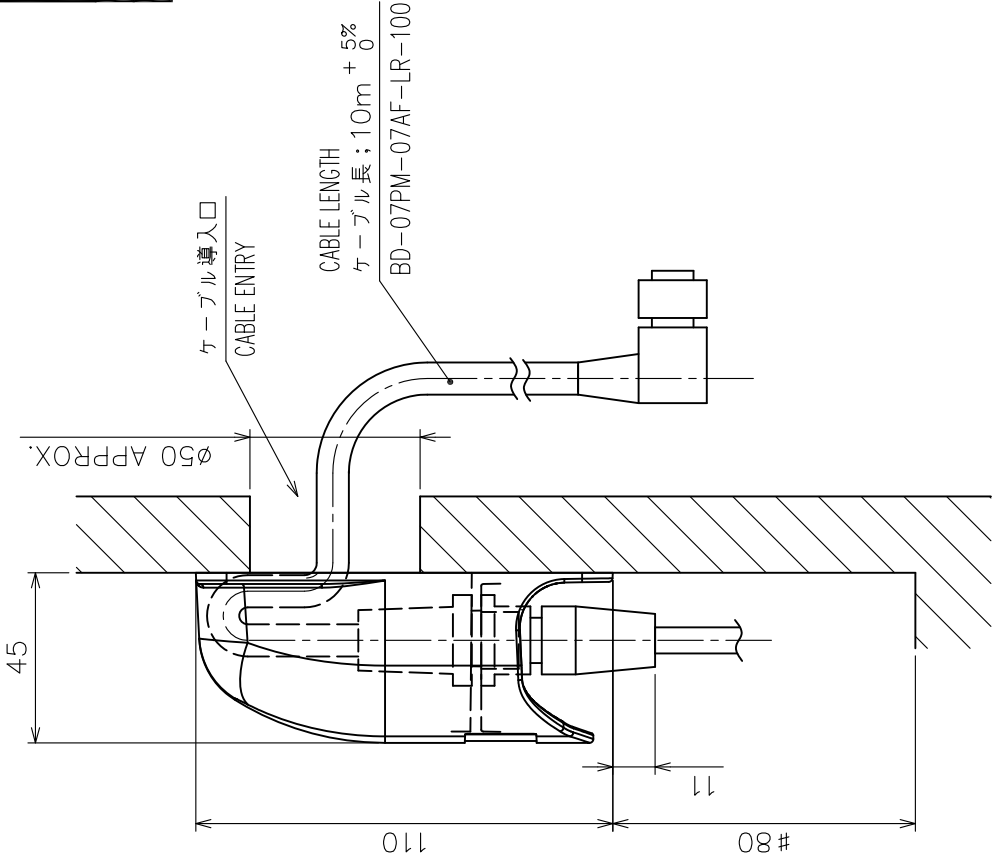

注 記

- 1) 指定外の寸法公差は表1による。
- 2) #印寸法は最小サービスマージン寸法とする。
- 3) 取付用ネジはトラスタツピンネジ呼び径4×20を使用のこと。

NOTE

1. TABLE 1 INDICATES TOLERANCE OF DIMENSIONS WHICH IS NOT SPECIFIED.
2. #. MINIMUM SERVICE CLEARANCE.
3. USE TAPPING SCREWS φ4x20 FOR FIXING THE UNIT.

DRAWN	22/Dec/09	T. YAMASAKI	TITLE	FAP-7822
CHECKED	22/Dec/09	I. TAKENO	名称	ケーブル延長ユニット
APPROVED	25/Jan/10	R. ESUMI	外寸図	
SCALE	1/100	質量はケーブルを含まず MASS W/O CABLE	NAME	JUNCTION BOX
DWG.No.	C7274-G02-B	REF.No.	64-028-401G-0	OUTLINE DRAWING

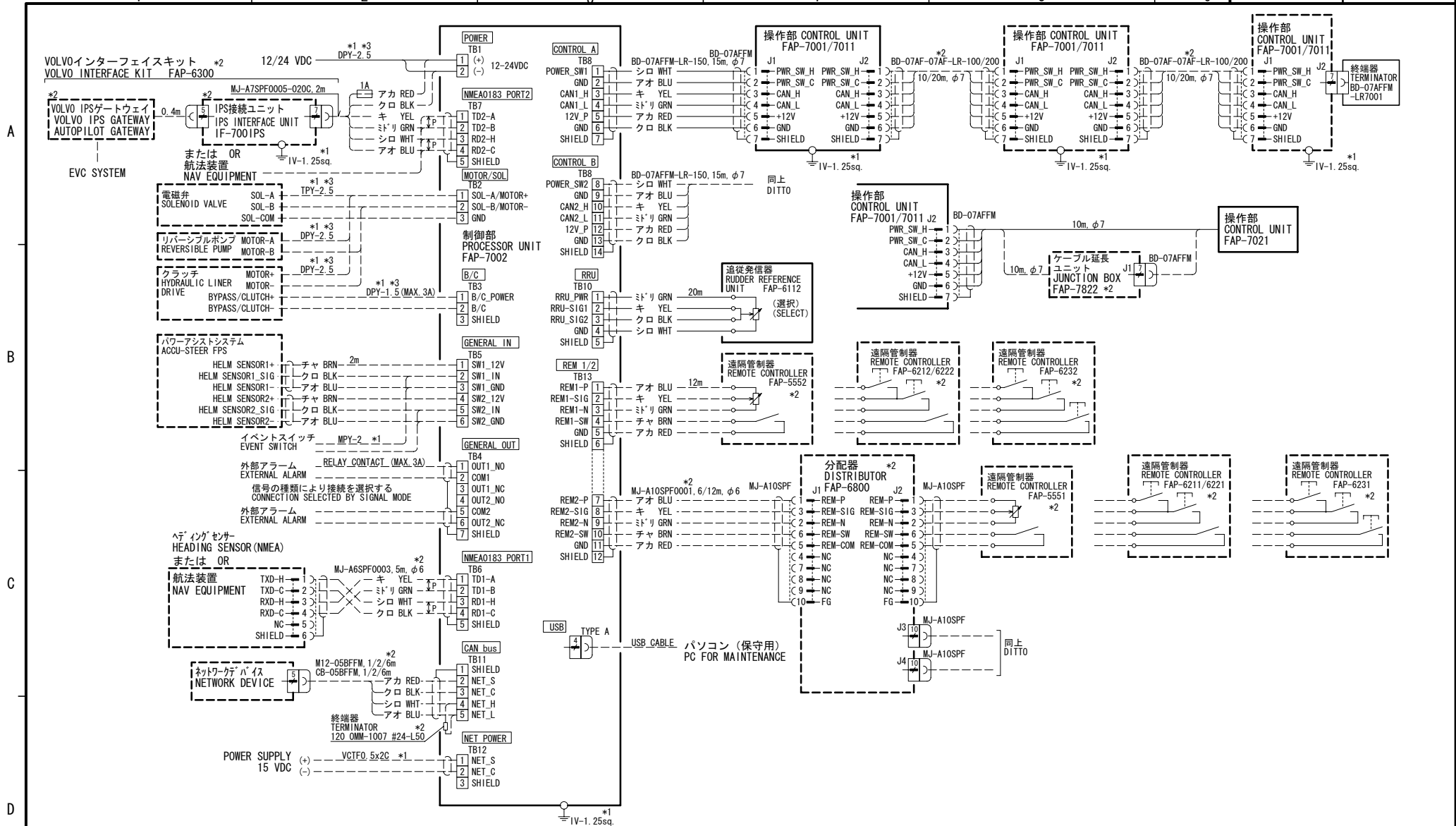

注記  
 \* 1) 造船所手配。  
 \* 2) オプション。  
 \* 3) ケーブル長さにより芯線の太さを変更する。

NOTE  
 \*1: SHIPYARD SUPPLY.  
 \*2: OPTION.  
 \*3: CHANGE THE CORE SIZE ACCORDING TO CABLE LENGTH.

DRAWN	7/0ct/2013 T. YAMASAKI	TITLE	NAVpilot-700/711/720
CHECKED	7/0ct/2013 H. MAKI	名称	自動操舵装置
APPROVED	7/0ct/2013 H. MAKI		相互結線図
SCALE	MASS kg	NAME	AUTOPILOT
DWG No.	C7272-C01-K	REF. No.	64-028-5001-2
			INTERCONNECTION DIAGRAM

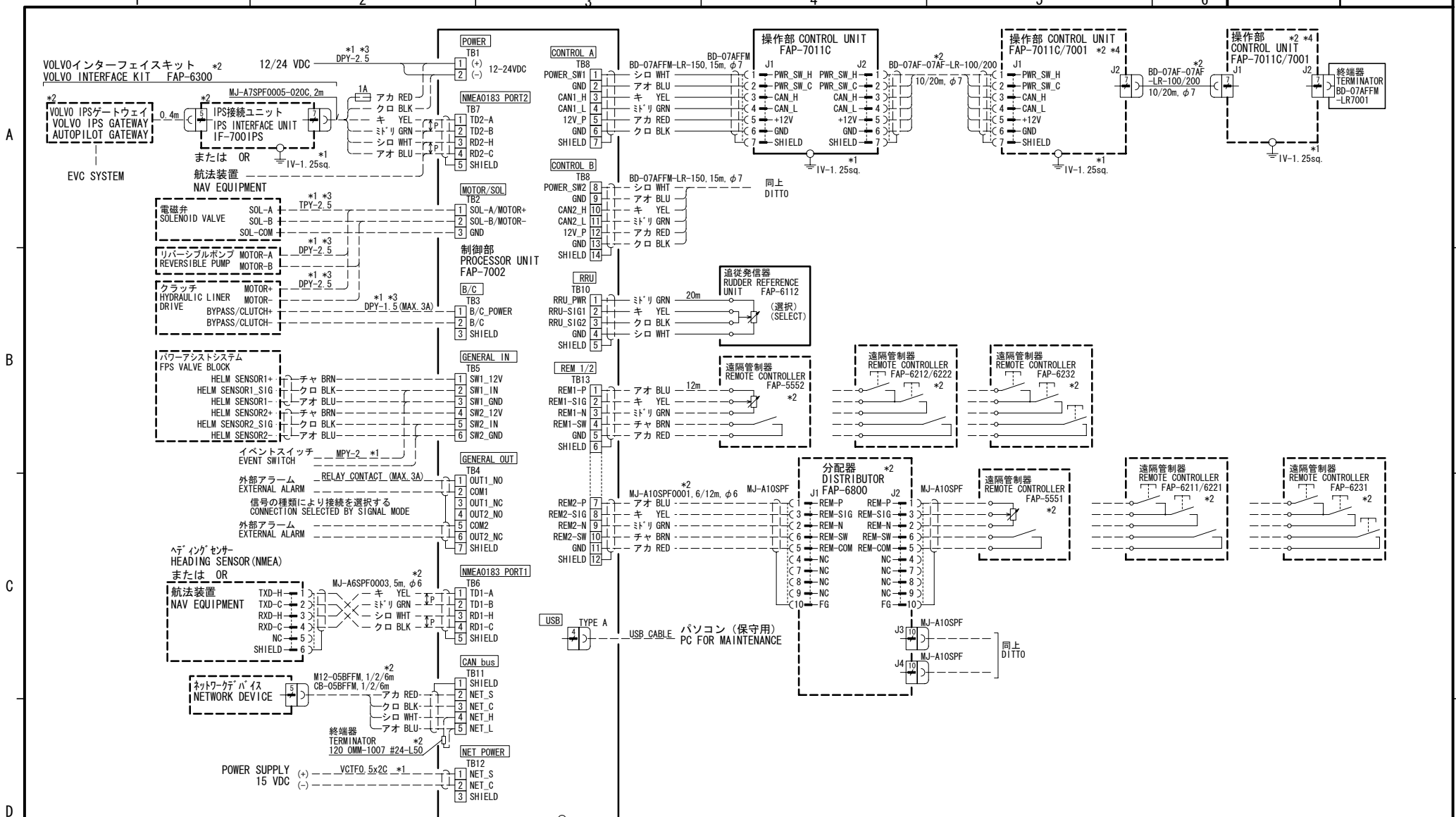

注記  
 \* 1) 造船所手配。  
 \* 2) オプション。  
 \* 3) ケーブル長さにより芯線の太さを変更する。  
 \* 4) 操作部は1ポート3台まで接続可能。

NOTE  
 \*1: SHIPYARD SUPPLY.  
 \*2: OPTION.  
 \*3: CHANGE THE CORE SIZE ACCORDING TO CABLE LENGTH.  
 \*4: THREE SETS OF CONTROL UNIT ARE AVAILABLE TO ONE PORT.

DRAWN	26/Sep/2013 T. YAMASAKI	TITLE	NAVpilot-711C
CHECKED	26/Sep/2013 H. MAKI	名称	自動操舵装置
APPROVED	26/Sep/2013 H. MAKI		相互結線図
SCALE	MASS kg	NAME	AUTOPILLOT
DWG No.	C7278-C01- A	REF. No.	INTERCONNECTION DIAGRAM

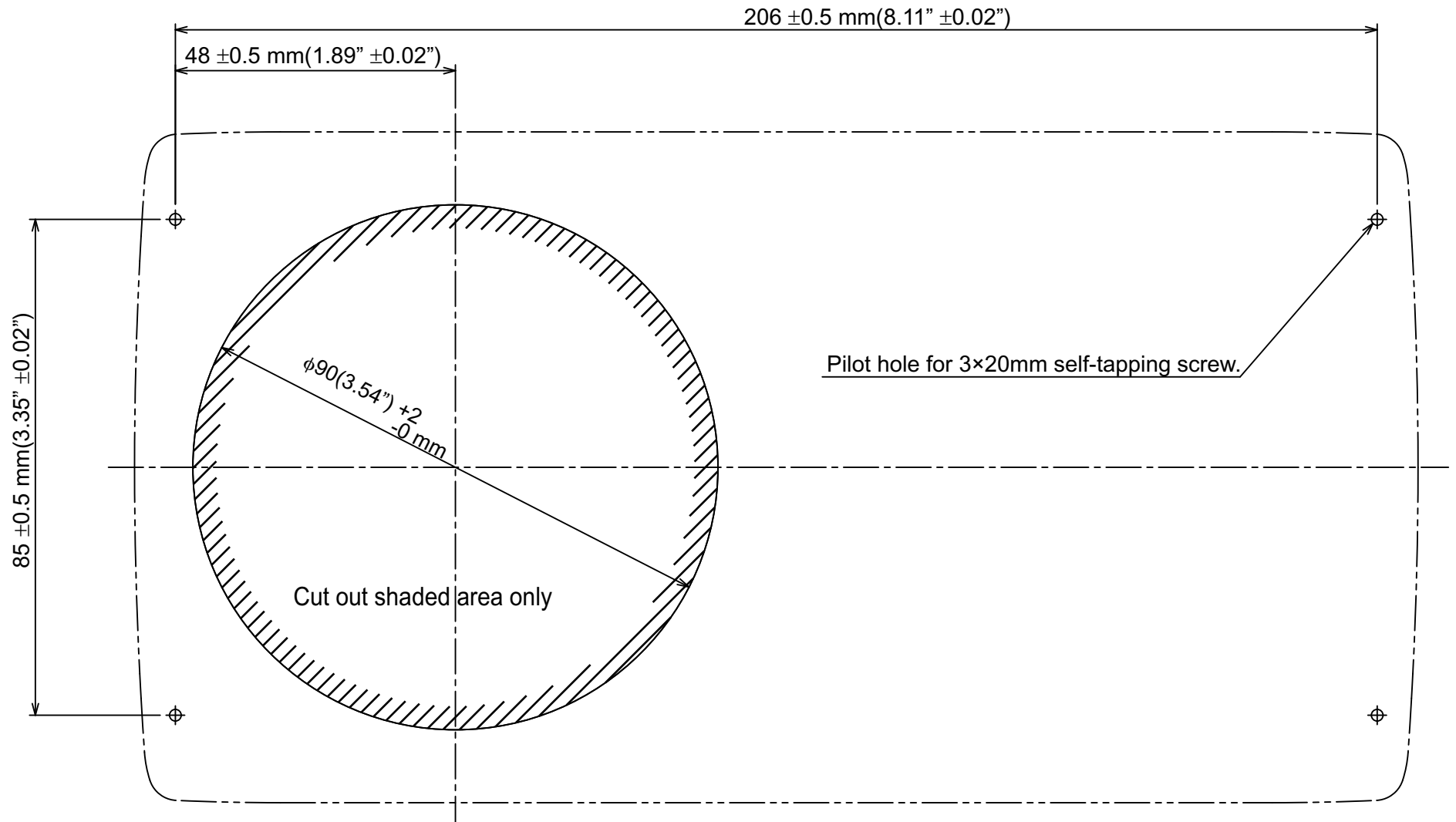

Control Unit FAP-7001  
Surface Mount Template



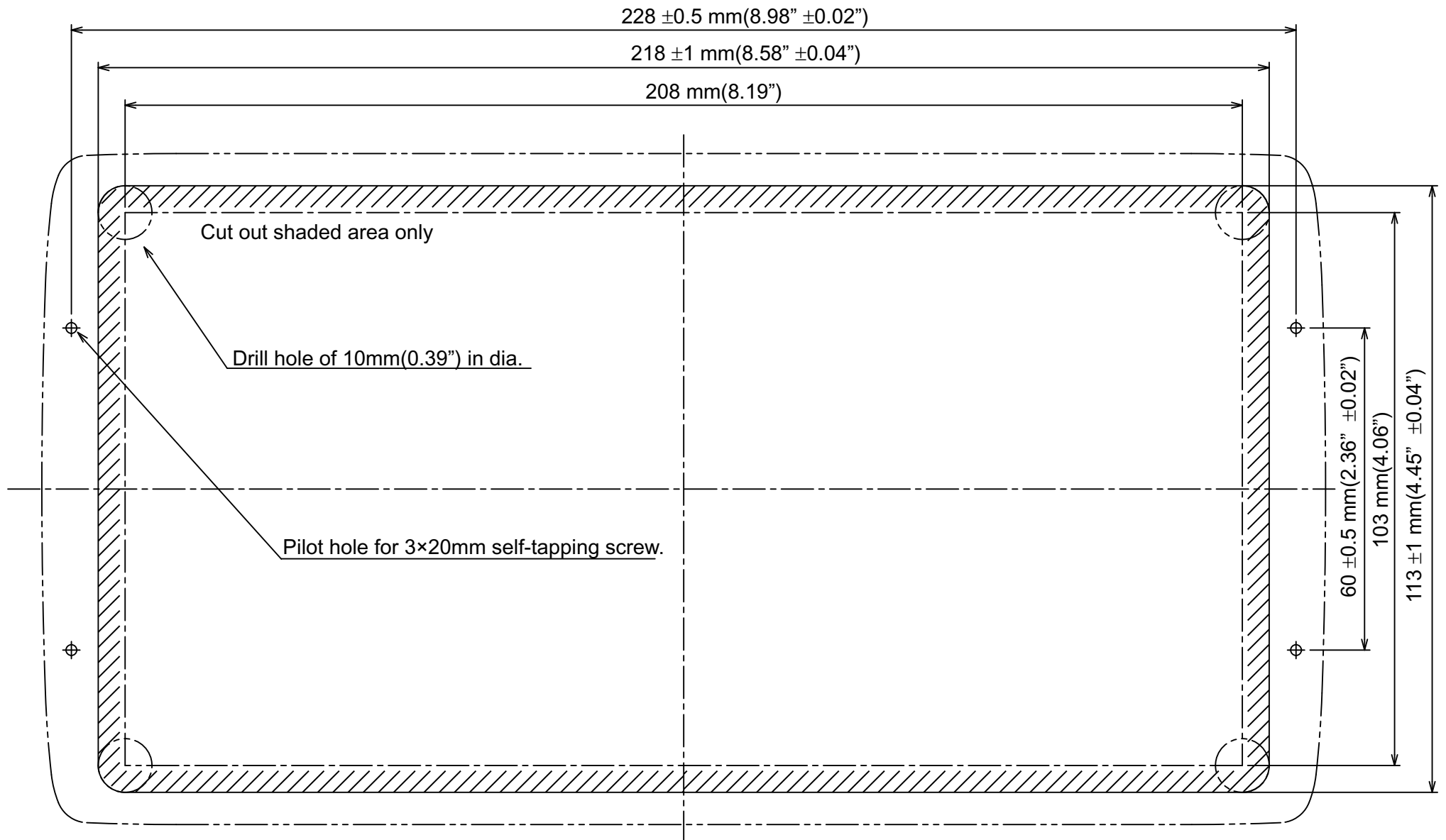

Control Unit FAP-7001  
Flush Mount Template

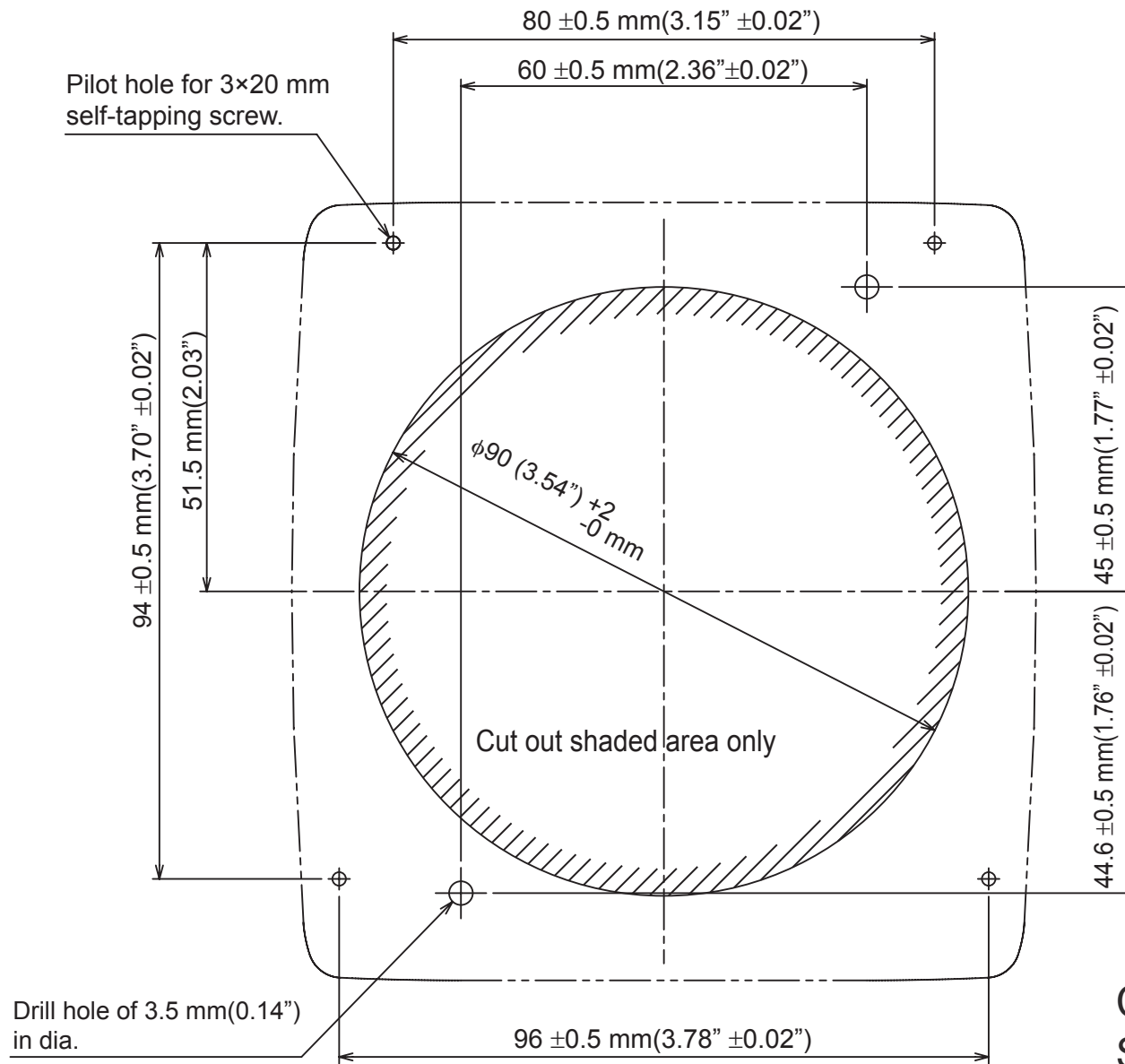

Control Unit FAP-7011  
Surface Mount Template

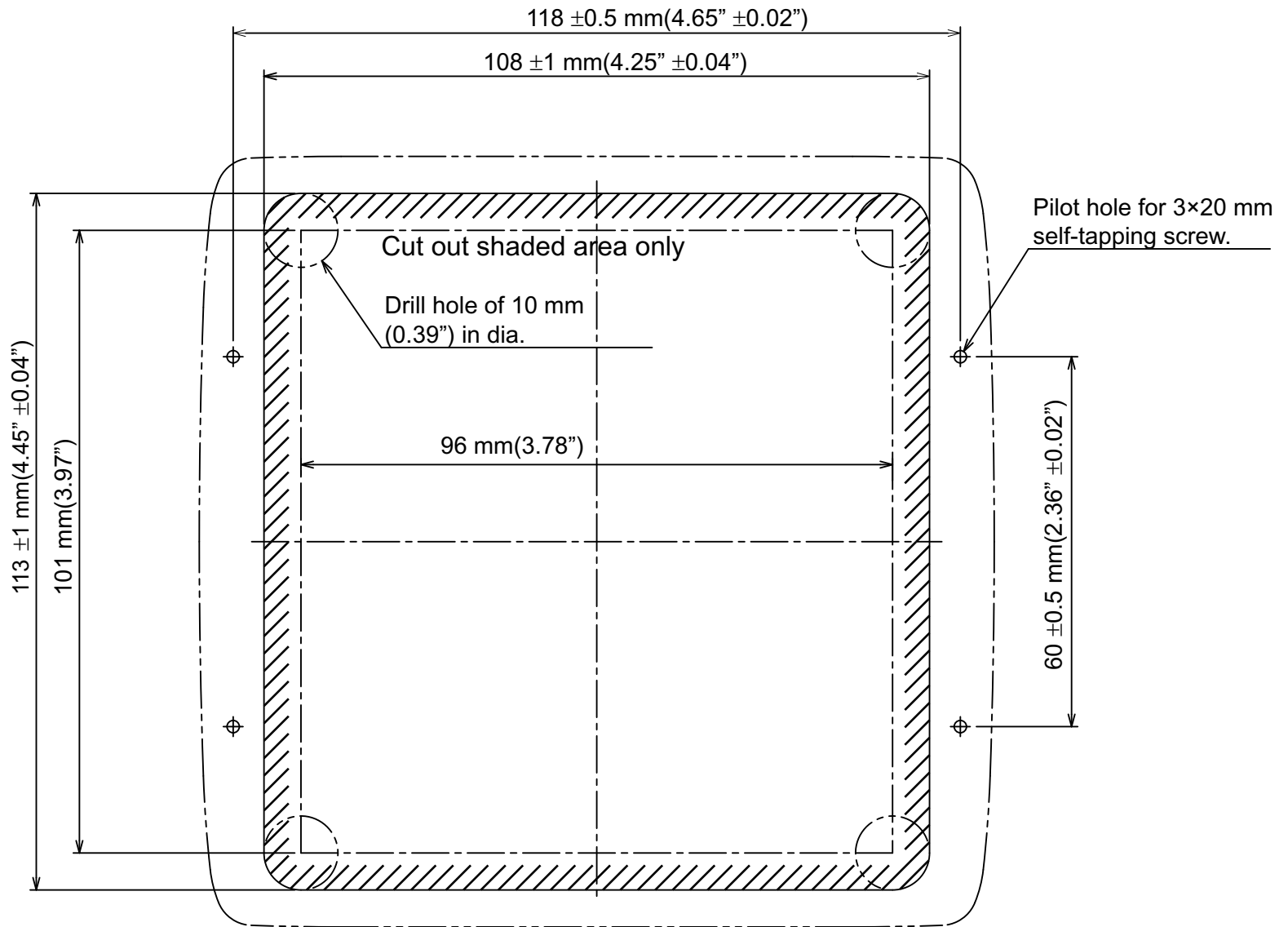

Control Unit FAP-7011  
Flush Mount Template